



PUBLIC WORKS DEPARTMENT • 10300 TORRE AVENUE • CUPERTINO, CALIFORNIA 95014

PROJECT MANUAL

FOR THE

2025 Slurry Seal / Fog Seal Project

Bid Dates:

Bid Package posted:	Tuesday, January 28
RFI's due date:	Wednesday, February 12, 2pm
Submittals due:	Wednesday, February 19, 2pm

APPROVED BY:

A handwritten signature in blue ink, appearing to read 'Chad Mosley', is written over a horizontal line.

Chad Mosley, PE,
Director of Public Works & City Engineer

PROJECT INFORMATION:

Location: City of Cupertino, Various City Streets

Project Overview: Slurry Seal, Fog Seal, Crack Seal, Traffic Striping and Markings

PROJECT DIRECTORY

City Representative: **City of Cupertino**

**Use this Address for Stop Notices*

Jo Anne Johnson Project Manager City of Cupertino - Public Works 10300 Torre Avenue Cupertino, CA 95014 PH: (408) 777-3354 Email: joannej@cupertino.org

TABLE OF CONTENTS

Notice Inviting Bids	1
Instructions to Bidders	3
Bid Proposal.....	9
Bid Schedule.....	12
Subcontractor List.....	14
Noncollusion Declaration	16
Bid Bond.....	17
Bidder’s Questionnaire	19
Contract	26
Payment Bond.....	32
Performance Bond	34
General Conditions	36
Article 1 - Definitions.....	36
Definitions.....	36
Article 2 - Roles and Responsibilities	39
2.1 City	39
2.2 Contractor.....	39
2.3 Subcontractors	42
2.4 Coordination of Work.....	43
2.5 Submittals.....	43
2.6 Shop Drawings	44
Article 3 - Contract Documents.....	45
3.1 Interpretation of Contract Documents	45
3.2 Order of Precedence	45
3.3 Caltrans Standard Specifications	46
3.4 For Reference Only	46
3.5 Current Versions	47
3.6 Conformed Copies	47
Article 4 - Bonds, Indemnity, and Insurance	47
4.1 Payment and Performance Bonds	47
4.2 Indemnity	47
4.3 Insurance.....	48
Article 5 - Contract Time	50
5.1 Time is of the Essence	50
5.2 Schedule Requirements	50
5.3 Delay and Extensions of Contract Time.....	52
5.4 Liquidated Damages	55
Article 6 - Contract Modification	56
6.1 Contract Modification.....	56
6.2 Contractor Change Order Requests	57
6.3 Adjustments to Contract Price.....	58
6.4 Unilateral Change Order	58
6.5 Non-Compliance Deemed Waiver.....	59
Article 7 - General Construction Provisions.....	59
7.1 Permits, Fees, Business License, and Taxes	59
7.2 Temporary Facilities	59
7.3 Noninterference and Site Management	59
7.4 Signs.....	60
7.5 Project Site and Nearby Property Protections.....	60
7.6 Materials and Equipment.....	61

7.7	Substitutions	63
7.8	Testing and Inspection	63
7.9	Project Site Conditions and Maintenance	65
7.10	Instructions and Manuals	66
7.11	As-built Drawings	67
7.12	Existing Utilities	67
7.13	Notice of Excavation.....	68
7.14	Trenching and Excavations of Four Feet or More.....	68
7.15	Trenching of Five Feet or More	68
7.16	New Utility Connections	68
7.17	Lines and Grades.	69
7.18	Historic or Archeological Items.....	69
7.19	Environmental Control.....	69
7.20	Noise Control.....	69
7.21	Mined Materials.	69
Article 8 - Payment		70
8.1	Schedule of Values	70
8.2	Progress Payments. Following the last day of each month, or as otherwise required by the Special Conditions or Specifications, Contractor will submit to the Project Manager for approval, a monthly application for payment for Work performed during the preceding month based on the estimated value of the Design Services or Construction Services performed during that preceding month.	70
8.3	Adjustment of Payment Application	71
8.4	Early Occupancy.	72
8.5	Retention	72
8.6	Payment to Subcontractors and Suppliers.....	72
8.7	Final Payment	73
8.8	Release of Claims	73
8.9	Warranty of Title	73
Article 9 - Labor Provisions		73
9.1	Discrimination Prohibited.....	73
9.2	Labor Code Requirements	73
9.3	Prevailing Wages	74
9.4	Payroll Records	74
9.5	Labor Compliance	75
Article 10 - Safety Provisions		75
10.1	Safety Precautions and Programs	75
10.2	Hazardous Materials	76
10.3	Material Safety	76
10.4	Hazardous Condition.....	76
10.5	Emergencies	76
Article 11 - Completion and Warranty Provisions.....		76
11.1	Final Completion	76
11.2	Warranty	77
11.3	Use Prior to Final Completion	78
11.4	Substantial Completion	79
Article 12 - Dispute Resolution		79
12.1	Claims.....	79
12.2	Claims Submission.....	79
12.3	City's Response	81
12.4	Meet and Confer.....	81
12.5	Mediation and Government Code Claims	82
12.6	Tort Claims	82
12.7	Arbitration	82
12.8	Burden of Proof and Limitations.....	82

12.9	Legal Proceedings.....	83
12.10	Other Disputes	83
Article 13 - Suspension and Termination.....		83
13.1	Suspension for Cause.....	83
13.2	Suspension for Convenience	84
13.3	Termination for Default.....	84
13.4	Termination for Convenience	85
13.5	Actions Upon Termination for Default or Convenience.....	86
Article 14 - Miscellaneous Provisions		87
14.1	Assignment of Unfair Business Practice Claims	87
14.2	Provisions Deemed Inserted.....	87
14.3	Waiver	87
14.4	Titles, Headings, and Groupings.....	87
14.5	Statutory and Regulatory References.....	87
14.6	Survival.....	87
Special Conditions		88
Technical Specifications.....		95
Caltrans Standard Detail.....		113
Estimated Quantities.....		127
Location Map.....		137
Truck Traffic Restrictions Map.....		138
Cupertino Unified School District Calendar.....		139
Attachment A - Authorized Lane Closure Hours.....		141

Notice Inviting Bids

1. **Bid Submission.** City of Cupertino ("City") will accept sealed bids for its **2025 Slurry Seal / Fog Seal Project** ("Project"), by or before Wednesday, February 19, 2025, at 2:00 PM, via electronic submission to the City's "Business Opportunities" online portal in the manner set forth in Section 1 of the Instructions to Bidders, at which time the bids will be opened by the City.
2. **Project Information.**
 - 2.1 **Location and Description.** The Project is located on various residential streets in the City of Cupertino and is described as follows: Approximately 143,000 square yards of Slurry Seal & Crack Seal, 150,000 square yards of fog seal and replacement of traffic striping and legends.
 - 2.2 **Time for Final Completion.** The Project must be fully completed within 70 calendar days from the start date set forth in the Notice to Proceed. City anticipates that the Work will begin on or about April 14, 2025, but the anticipated start date is provided solely for convenience and is neither certain nor binding.
3. **License and Registration Requirements.**
 - 3.1 **License.** This Project requires a valid California contractor's license for the following classification(s): Class A, Class C-12 or Class C-32
 - 3.2 **DIR Registration.** City may not accept a Bid Proposal from or enter into the Contract with a bidder, without proof that the bidder is registered with the California Department of Industrial Relations ("DIR") to perform public work pursuant to Labor Code § 1725.5, subject to limited legal exceptions.
4. **Contract Documents.** The plans, specifications, bid forms and contract documents for the Project, and any addenda thereto ("Contract Documents") may be downloaded from City's Business Opportunities website located at: <https://apps.cupertino.gov/bidManagement/index.aspx>. A printed copy of the Contract Documents is not available.
5. **Bid Security.** The Bid Proposal must be accompanied by bid security of ten percent of the maximum bid amount, in the form of a cashier's or certified check made payable to City, or a bid bond executed by a surety licensed to do business in the State of California on the Bid Bond form included with the Contract Documents. The bid security must guarantee that within ten days after City issues the Notice of Potential Award, the successful bidder will execute the Contract and submit the payment and performance bonds, insurance certificates and endorsements, valid Certificates of Reported Compliance as required under the California Air Resources Board's In-Use Off-Road Diesel-Fueled Fleets Regulation (13 CCR § 2449 et seq.) ("Off-Road Regulation"), if applicable, and any other submittals required by the Contract Documents and as specified in the Notice of Potential Award.
6. **Prevailing Wage Requirements.**
 - 6.1 **General.** Pursuant to California Labor Code § 1720 et seq., this Project is subject to the prevailing wage requirements applicable to the locality in which the Work is to be performed for each craft, classification or type of worker needed to perform the Work, including employer payments for health and welfare, pension, vacation, apprenticeship and similar purposes.

- 6.2 Rates.** The prevailing rates are on file with the City and are available online at <http://www.dir.ca.gov/DLSR>. Each Contractor and Subcontractor must pay no less than the specified rates to all workers employed to work on the Project. The schedule of per diem wages is based upon a working day of eight hours. The rate for holiday and overtime work must be at least time and one-half.
- 6.3 Compliance.** The Contract will be subject to compliance monitoring and enforcement by the DIR, under Labor Code § 1771.4.
- 7. Performance and Payment Bonds.** The successful bidder will be required to provide performance and payment bonds, each for 100% of the Contract Price, as further specified in the Contract Documents.
- 8. Substitution of Securities.** Substitution of appropriate securities in lieu of retention amounts from progress payments is permitted under Public Contract Code § 22300.
- 9. Subcontractor List.** Each Subcontractor must be registered with the DIR to perform work on public projects. Each bidder must submit a completed Subcontractor List form with its Bid Proposal, including the name, location of the place of business, California contractor license number, DIR registration number, and percentage of the Work to be performed (based on the base bid price) for each Subcontractor that will perform Work or service or fabricate or install Work for the prime contractor in excess of one-half of 1% of the bid price, using the Subcontractor List form included with the Contract Documents.
- 10. Instructions to Bidders.** All bidders should carefully review the Instructions to Bidders for more detailed information before submitting a Bid Proposal. The definitions provided in Article 1 of the General Conditions apply to all of the Contract Documents, as defined therein, including this Notice Inviting Bids.
- 11. Percentage.** The percentage of retention that will be withheld from progress payments is 50 %.

Signed:  1/28/25
Kirsten Squarcia, City Clerk _____ Date

Publication Date: 1/31/25

END OF NOTICE INVITING BIDS

Instructions to Bidders

Each Bid Proposal submitted to the City of Cupertino ("City") for its **2025 Slurry Seal / Fog Seal Project** ("Project") must be submitted in accordance with the following instructions and requirements:

1. Bid Submission.

- 1.1 General.** Each Bid Proposal must be completed, using the form provided in the Contract Documents, signed, and submitted to City in a sealed envelope, with all required forms and attachments, by or before the date and time set forth in Section 1 of the Notice Inviting Bids, or as amended by subsequent addendum. Faxed or emailed Bid Proposals will not be accepted, unless otherwise specified. Late submissions will be returned unopened. City reserves the right to postpone the date or time for receiving or opening bids. Each bidder is solely responsible for all of its costs to prepare and submit its bid and by submitting a bid waives any right to recover those costs from City. The bid price(s) must include all costs to perform the Work as specified, including all labor, material, supplies, and equipment and all other direct or indirect costs such as applicable taxes, insurance and overhead.
- 1.2 Electronic Submission.** The Bid Proposal and all required forms and attachments must be submitted in PDF format on the City's "Business Opportunities" portal at <https://apps.cupertino.gov/bidManagement/index.aspx>. To submit a bid, (1) select the folder icon in the "Actions" column for the Project; (2) select the "Electronic Submission" tab; (3) when the log-in screen appears, enter the log-in credentials used to access the Contract Documents and/or create an account, as appropriate; (4) after logging in, carefully follow all instructions for electronic submission of the Bid Proposal and all required forms and attachments. Each bidder should familiarize itself with the City's "Business Opportunities" portal before the bid deadline. Electronic submission may take more time than anticipated. Each bidder should plan accordingly and afford itself ample time to upload its bid. Bids that are in the process of uploading but are not completely uploaded by the bid deadline will be automatically rejected by the portal. The portal will not allow submission after the bid deadline.
- 1.3 Bid Posting.** The amount of each bid and such other relevant information as the City deems appropriate, together with the name of each bidder, shall be posted on the City website <https://apps.cupertino.gov/bidManagement/index.aspx> on the first working day following a period of 48 hours after the bid opening and remain open to public inspection for a period of not less than fifteen (15) calendar days after the bid opening.
- 1.3 DIR Registration.** Subject to limited legal exceptions for joint venture bids and federally-funded projects, City may not accept a Bid Proposal from a bidder without proof that the bidder is registered with the DIR to perform public work under Labor Code § 1725.5. If City is unable to confirm that the bidder is currently registered with the DIR, City may disqualify the bidder and return its bid unopened. (Labor Code §§ 1725.5 and 1771.1(a).)

- 2. Bid Proposal Form and Enclosures.** Each Bid Proposal must be completed legibly using the Bid Proposal form included with the Contract Documents. The Bid Proposal form must be fully completed without interlineations, alterations, or erasures. Any necessary corrections must be clear and legible and must be initialed by the bidder's authorized

representative. A Bid Proposal submitted with exceptions or terms such as “negotiable,” “will negotiate,” or similar, will be considered nonresponsive. Each Bid Proposal must be accompanied by bid security, as set forth in Section 4 below, and by a completed Subcontractor List and Non-Collusion Declaration using the forms included with the Contract Documents, and any other required enclosures, as applicable.

- 3. Authorization and Execution.** Each Bid Proposal must be signed by the bidder’s authorized representative. A Bid Proposal submitted by a partnership must be signed in the partnership name by a general partner with authority to bind the partnership. A Bid Proposal submitted by a corporation must be signed with the legal name of the corporation, followed by the signature and title of two officers of the corporation with full authority to bind the corporation to the terms of the Bid Proposal, under California Corporations Code § 313.
- 4. Bid Security.** Each Bid Proposal must be accompanied by bid security of ten percent of the maximum bid amount, in the form of a cashier’s check or certified check, made payable to the City, or bid bond using the form included in the Contract Documents and executed by a surety licensed to do business in the State of California.

 - 4.1 Form of Security and Submission.** In addition to submitting a PDF copy of the bid security, the wet-inked original bid bond, cashier’s or certified check, must be sent to the City via U.S. Mail or a reliable overnight delivery service in a sealed envelope addressed to City of Cupertino, Office of the City Clerk, 10300 Torre Avenue, Cupertino, CA 95014 and clearly labeled with the bidder’s legal name and address, the Project title, and date and time of the bid deadline. The envelope containing the original form of bid security must be postmarked or otherwise dated to show that it was submitted to the United States Postal Service or overnight delivery service by or before the date of the bid deadline.
 - 4.2 Bid Guarantee.** The bid security must guarantee that, within ten days after issuance of the Notice of Potential Award, the bidder will: execute and submit the enclosed Contract for the bid price; submit payment and performance bonds for 100% of the maximum Contract Price; submit the insurance certificates and endorsements; and submit valid Certificates of Reported Compliance as required by the Off-Road Regulation, if applicable, and any other submittals, if any, required by the Contract Documents or the Notice of Potential Award. A Bid Proposal may not be withdrawn for a period of 60 days after the bid opening without forfeiture of the bid security, except as authorized for material error under Public Contract Code § 5100 et seq.
- 5. Requests for Information.** Questions or requests for clarifications regarding the Project, the bid procedures, or any of the Contract Documents must be submitted in writing to Jo Anne Johnson, Project Manager, at joanej@cupertino.gov with the following text in the subject line “2025 Slurry Seal/Fog Seal Project”. Oral responses are not authorized and are not binding on the City. Bidders should submit any such written inquiries at least five Working Days before the scheduled bid opening. Questions received later may not be addressed before the bid deadline. An interpretation or clarification by City in response to a written inquiry will be issued in an addendum.
- 6. Pre-Bid Investigation.**

 - 6.1 General.** Each bidder is solely responsible at its sole expense for diligent and thorough review of the Contract Documents, examination of the Project site, and reasonable and prudent inquiry concerning known and potential site and area conditions prior to submitting a Bid Proposal. Each bidder is responsible for knowledge of conditions and requirements which reasonable review and

investigation would have disclosed. However, except for any areas that are open to the public at large, bidders may not enter property owned or leased by the City or the Project site without prior written authorization from City.

- 6.2 Document Review.** Each bidder is responsible for review of the Contract Documents and any informational documents provided “For Reference Only,” e.g., as-builts, technical reports, test data, and the like. A bidder is responsible for notifying City of any errors, omissions, inconsistencies, or conflicts it discovers in the Contract Documents, acting solely in its capacity as a contractor and subject to the limitations of Public Contract Code § 1104. Notification of any such errors, omissions, inconsistencies, or conflicts must be submitted in writing to the City no later than five Working Days before the scheduled bid opening. (See Section 5, above.) City expressly disclaims responsibility for assumptions a bidder might draw from the presence or absence of information provided by City.
- 6.3 Project Site.** Questions regarding the availability of soil test data, water table elevations, and the like should be submitted to the City in writing, as specified in Section 5, above. Any subsurface exploration at the Project site must be done at the bidder’s expense, but only with prior written authorization from City. All soil data and analyses available for inspection or provided in the Contract Documents apply only to the test hole locations. Any water table elevation indicated by a soil test report existed on the date the test hole was drilled. The bidder is responsible for determining and allowing for any differing soil or water table conditions during construction. Because groundwater levels may fluctuate, difference(s) in elevation between ground water shown in soil boring logs and ground water actually encountered during construction will not be considered changed Project site conditions. Actual locations and depths must be determined by bidder’s field investigation. The bidder may request access to underlying or background information on the Project site in City’s possession that is necessary for the bidder to form its own conclusions, including, if available, record drawings or other documents indicating the location of subsurface lines, utilities, or other structures.
- 6.4 Utility Company Standards.** The Project must be completed in a manner that satisfies the standards and requirements of any affected utility companies or agencies (collectively, “utility owners”). The successful bidder may be required by the third-party utility owners to provide detailed plans prepared by a California registered civil engineer showing the necessary temporary support of the utilities during coordinated construction work. Bidders are directed to contact the affected third-party utility owners about their requirements before submitting a Bid Proposal.
- 7. Bidders Interested in More Than One Bid.** No person, firm, or corporation may submit or be a party to more than one Bid Proposal unless alternate bids are specifically called for. However, a person, firm, or corporation that has submitted a subcontract proposal or quote to a bidder may submit subcontract proposals or quotes to other bidders.
- 8. Addenda.** Subject to the limitations of Public Contract Code § 4104.5, City reserves the right to issue addenda prior to bid time. Any addenda issued prior to the bid opening are part of the Contract Documents. Each bidder is solely responsible for ensuring it has received and reviewed all addenda prior to submitting its bid. Bidders should check City’s website periodically for any addenda or updates on the Project at: <https://apps.cupertino.gov/bidManagement/index.aspx>.
- 9. Brand Designations and “Or Equal” Substitutions.** Any specification designating a material, product, thing, or service by specific brand or trade name, followed by the words “or equal,” is intended only to indicate quality and type of item desired, and bidders may

request use of any equal material, product, thing, or service. All data substantiating the proposed substitute as an equal item must be submitted with the written request for substitution. A request for substitution must be submitted within 35 days after Notice of Potential Award unless otherwise provided in the Contract Documents. This provision does not apply to materials, products, things, or services that may lawfully be designated by a specific brand or trade name under Public Contract Code § 3400(c).

10. Bid Protest. Any bid protest against another bidder must be submitted in writing and received by City at 10300 Torre Ave, Cupertino, CA 95014 Attn: City Clerk or sent via email at joannej@cupertino.org before 5:00 p.m. no later than two Working Days following bid opening (“Bid Protest Deadline”) and must comply with the following requirements:

10.1 General. Only a bidder who has actually submitted a Bid Proposal is eligible to submit a bid protest against another bidder. Subcontractors are not eligible to submit bid protests. A bidder may not rely on the bid protest submitted by another bidder but must timely pursue its own protest. For purposes of this Section 10, a “Working Day” means a day that City is open for normal business, and excludes weekends and holidays observed by City. Pursuant to Public Contract Code § 4104, inadvertent omission of a Subcontractor’s DIR registration number on the Subcontractor List form is not grounds for a bid protest, provided it is corrected within 24 hours of the bid opening or as otherwise provided under Labor Code § 1771.1(b).

10.2 Protest Contents. The bid protest must contain a complete statement of the basis for the protest and must include all supporting documentation. Material submitted after the Bid Protest Deadline will not be considered. The protest must refer to the *specific* portion or portions of the Contract Documents upon which the protest is based. The protest must include the name, address, email address, and telephone number of the protesting bidder and any person submitting the protest on behalf of or as an authorized representative of the protesting bidder.

10.3 Copy to Protested Bidder. Upon submission of its bid protest to City, the protesting bidder must also concurrently transmit the protest and all supporting documents to the protested bidder, and to any other bidder who has a reasonable prospect of receiving an award depending upon the outcome of the protest, by email or hand delivery to ensure delivery before the Bid Protest Deadline.

10.4 Response to Protest. The protested bidder may submit a written response to the protest, provided the response is received by City before 5:00 p.m., within two Working Days after the Bid Protest Deadline or after actual receipt of the bid protest, whichever is sooner (the “Response Deadline”). The response must attach all supporting documentation. Material submitted after the Response Deadline will not be considered. The response must include the name, address, email address, and telephone number of the person responding on behalf of or representing the protested bidder if different from the protested bidder.

10.5 Copy to Protesting Bidder. Upon submission of its response to the bid protest to the City, the protested bidder must also concurrently transmit by email or hand delivery, by or before the Response Deadline, a copy of its response and all supporting documents to the protesting bidder and to any other bidder who has a reasonable prospect of receiving an award depending upon the outcome of the protest.

10.6 Exclusive Remedy. The procedure and time limits set forth in this Section are mandatory and are the bidder’s sole and exclusive remedy in the event of a bid

protest. A bidder's failure to comply with these procedures will constitute a waiver of any right to further pursue a bid protest, including filing a Government Code Claim or initiation of legal proceedings.

- 10.7 Right to Award.** City reserves the right, acting in its sole discretion, to reject any bid protest that it determines lacks merit; to award the Contract to the bidder it has determined to be the responsible bidder submitting the lowest responsive bid, and to issue a Notice to Proceed with the Work notwithstanding any pending or continuing challenge to its determination.
- 11. Reservation of Rights.** City reserves the unfettered right, acting in its sole discretion, to waive or to decline to waive any immaterial bid irregularities; to accept or reject any or all bids; to cancel or reschedule the bid; to postpone or abandon the Project entirely; or to perform all or part of the Work with its own forces. The Contract will be awarded, if at all, within 60 days after opening of bids or as otherwise specified in the Special Conditions, to the responsible bidder that submitted the lowest responsive bid. Any planned start date for the Project represents the City's expectations at the time the Notice Inviting Bids was first issued. City is not bound to issue a Notice to Proceed by or before such planned start date, and it reserves the right to issue the Notice to Proceed when the City determines, in its sole discretion, the appropriate time for commencing the Work. The City expressly disclaims responsibility for any assumptions a bidder might draw from the presence or absence of information provided by the City in any form. Each bidder is solely responsible for its costs to prepare and submit a bid, including site investigation costs.
- 12. Bonds.** Within ten calendar days following City's issuance of the Notice of Potential Award to the successful bidder, the bidder must submit payment and performance bonds to City as specified in the Contract Documents using the bond forms included in the Contract Documents. All required bonds must be calculated on the maximum total Contract Price as awarded, including additive alternates, if applicable.
- 13. License(s).** The successful bidder and its Subcontractor(s) must possess the California contractor's license(s) in the classification(s) required by law to perform the Work. The successful bidder must also obtain a City business license within 10 days following City's issuance of the Notice of Potential Award. Subcontractors must also obtain a City business license before performing any Work.
- 14. Ineligible Subcontractor.** Any Subcontractor who is ineligible to perform work on a public works project under Labor Code §§ 1777.1 or 1777.7 is prohibited from performing work on the Project.
- 15. Safety Orders.** If the Project includes construction of a pipeline, sewer, sewage disposal system, boring and jacking pits, or similar trenches or open excavations, which are five feet or deeper, each bid must include a bid item for adequate sheeting, shoring, and bracing, or equivalent method, for the protection of life or limb, which comply with safety orders as required by Labor Code § 6707.
- 16. In-Use Off-Road Diesel-Fueled Fleets.** If the Project involves the use of vehicles subject to the California Air Resources Board's In-Use Off-Road Diesel-Fueled Fleets Regulation (13 CCR § 2449 et seq.) ("Off-Road Regulation"), then within ten calendar days following City's issuance of the Notice of Potential Award to the successful bidder, the bidder must submit to City valid Certificates of Reported Compliance for its fleet and its listed Subcontractors, if applicable, in accordance with the Off-Road Regulation, unless exempt under the Off-Road Regulation.

- 17. Bid Schedule.** Each bidder must complete the Bid Schedule form with unit prices as indicated, and submit the completed Bid Schedule with its Bid Proposal.
- 17.1 Incorrect Totals.** In the event a computational error for any bid item (base bid or alternate) results in an incorrect extended total for that item, the submitted base bid or bid alternate total will be adjusted to reflect the corrected amount as the product of the estimated quantity and the unit cost. In the event of a discrepancy between the actual total of the itemized or unit prices shown on the Bid Schedule for the base bid, and the amount entered as the base bid on the Bid Proposal form, the actual total of the itemized or unit prices shown on the Bid Schedule for the base bid will be deemed the base bid price. Likewise, in the event of a discrepancy between the actual total of the itemized or unit prices shown on the Bid Schedule for any bid alternate, and the amount entered for the alternate on the Bid Proposal form, the actual total of the itemized prices shown on the Bid Schedule for that alternate will be deemed the alternate price. Nothing in this provision is intended to prevent a bidder from requesting to withdraw its bid for material error under Public Contract Code § 5100 et seq.
- 17.2 Estimated Quantities.** Unless identified as a “Final Pay Quantity,” the quantities shown on the Bid Schedule are estimated and the actual quantities required to perform the Work may be greater or less than the estimated amount. The Contract Price will be adjusted to reflect the actual quantities required for the Work based on the itemized or unit prices provided in the Bid Schedule, with no allowance for anticipated profit for quantities that are deleted or decreased, and no increase in the unit price, and without regard to the percentage increase or decrease of the estimated quantity and the actual quantity.
- 18. Bidder’s Questionnaire.** A completed, signed Bidder’s Questionnaire using the form provided with the Contract Documents and including all required attachments must be submitted within 48 hours following a request by City. A bid that does not fully comply with this requirement may be rejected as nonresponsive. A bidder who submits a Bidder’s Questionnaire which is subsequently determined to contain false or misleading information, or material omissions, may be disqualified as non-responsible.

END OF INSTRUCTIONS TO BIDDERS

Bid Proposal

2025 Slurry Seal / Fog Seal Project

_____ (“Bidder”) hereby submits this Bid Proposal to the City of Cupertino (“City”) for the above-referenced project (“Project”) in response to the Notice Inviting Bids and in accordance with the Contract Documents referenced in the Notice.

1. **Base Bid.** Bidder proposes to perform and fully complete the Work for the Project as specified in the Contract Documents, within the time required for full completion of the Work, including all labor, materials, supplies, and equipment and all other direct or indirect costs including, but not limited to, taxes, insurance and all overhead, for the following price (“Base Bid”):
\$_____.

2. **Addenda.** Bidder agrees that it has confirmed receipt of or access to, and reviewed, all addenda issued for this bid. Bidder waives any claims it might have against the City based on its failure to receive, access, or review any addenda for any reason. Bidder specifically acknowledges receipt of the following addenda:

Addendum	Date Received
#1	
#2	
#3	
#4	
#5	

3. **Bidder’s Certifications and Warranties.** By signing and submitting this Bid Proposal, Bidder certifies and warrants the following:

- 3.1 **Examination of Contract Documents.** Bidder has thoroughly examined the Contract Documents and represents that, to the best of Bidder’s knowledge, there are no errors, omissions, or discrepancies in the Contract Documents, subject to the limitations of Public Contract Code § 1104.
- 3.2 **Examination of Worksite.** Bidder has had the opportunity to examine the Worksite and local conditions at the Project location.
- 3.3 **Bidder Responsibility.** Bidder is a responsible bidder, with the necessary ability, capacity, experience, skill, qualifications, workforce, equipment, and resources to perform or cause the Work to be performed in accordance with the Contract Documents and within the Contract Time.
- 3.4 **Responsibility for Bid.** Bidder has carefully reviewed this Bid Proposal and is solely responsible for any errors or omissions contained in its completed bid. All statements and information provided in this Bid Proposal and enclosures are true and correct to the best of Bidder’s knowledge.
- 3.5 **Nondiscrimination.** In preparing this bid, the Bidder has not engaged in discrimination against any prospective or present employee or Subcontractor on grounds of race, color, ancestry, national origin, ethnicity, religion, sex, sexual orientation, age, disability, or marital status.

- 3.6 Iran Contracting Act.** If the Contract Price exceeds \$1,000,000, Bidder is not identified on a list created under the Iran Contracting Act, Public Contract Code § 2200 et seq. (the “Act”), as a person engaging in investment activities in Iran, as defined in the Act, or is otherwise expressly exempt under the Act.
- 4. Award of Contract.** By signing and submitting this Bid Proposal, Bidder agrees that, if City issues the Notice of Potential Award to Bidder, then within ten days following issuance of the Notice of Potential Award to Bidder, Bidder will do all of the following:
- 4.1 Execute Contract.** Enter into the Contract with City in accordance with the terms of this Bid Proposal, by signing and submitting to City the Contract prepared by City using the form included with the Contract Documents;
 - 4.2 Submit Required Bonds.** Submit to City a payment bond and a performance bond, each for 100% of the Contract Price, using the bond forms provided and in accordance with the requirements of the Contract Documents;
 - 4.3 Insurance Requirements.** Submit to City the insurance certificate(s) and endorsement(s) as required by the Contract Documents; and
 - 4.4 Certificates of Reported Compliance.** Submit to City valid Certificates of Reported Compliance for its fleet and its listed Subcontractors, if applicable, if the Project involves the use of vehicles subject to the Off-Road Regulation. (See Section 16 of the Instructions to Bidders.)
- 5. Bid Security.** As a guarantee that, if awarded the Contract, Bidder will perform its obligations under Section 4 above, Bidder is enclosing bid security in the amount of ten percent of its maximum bid amount in one of the following forms:

Check One:

	A cashier’s check or certified check payable to City and issued by [bank name] _____ in the amount of: \$ _____
	A bid bond, using the Bid Bond form included with the Contract Documents, payable to City and executed by a surety licensed to do business in the State of California.

This Bid Proposal is hereby submitted on _____, 2025.

s/ _____

Name and Title

s/ _____
[See Section 3 of Instructions to Bidders]

Name and Title

Company Name

License #, Expiration Date, and Classification

Address

DIR Registration #

City, State, Zip

Phone

Contact Name

Contact Email

END OF BID PROPOSAL

Bid Schedule

This Bid Schedule must be completed legibly and included with the sealed Bid Proposal. Pricing must be provided for each Bid Item as indicated. Items marked "(SW)" are Specialty Work that must be performed by a qualified Subcontractor. The lump sum or unit cost for each item must be inclusive of all costs, whether direct or indirect, including profit and overhead. The sum of all amounts entered in the "Extended Total Amount" column must be identical to the Base Bid price entered in Section 1 of the Bid Proposal form.

AL = Allowance
CF = Cubic Feet
CY = Cubic Yard

EA = Each
LB = Pounds
LF = Linear Foot

LS = Lump Sum
SF = Square Feet
TON = Ton (2000 lbs)

BID ITEM NO.	ITEM DESCRIPTION	EST. QTY.	UNIT	UNIT COST	EXTENDED TOTAL AMOUNT
1	Traffic Control	1	LS	\$	\$
2	Crack Seal	1	LS	\$	\$
3	Fog Seal	152,461	SY	\$	\$
4	Type II Slurry Seal	142,240	SY	\$	\$
5	Install Blue RPM's @ Fire Hydrant	52	EA	\$	\$
6	12" White Crosswalk/Limit Line (Thermo)	1841	LF	\$	\$
7	12" Yellow Crosswalk (Thermo)	405	LF	\$	\$
8	24" White (Thermo)	110	LF	\$	\$
9	24" Yellow (Thermo)	1590	LF	\$	\$
10	Striping Detail 22	2910	LF	\$	\$
11	Striping Detail 38	120	LF	\$	\$
12	Arrow Type IV Left (Preformed Thermo)	2	EA	\$	\$
13	Arrow Type IV Right (Preformed Thermo)	4	EA	\$	\$
14	Arrow Type I 10' (Preformed Thermo)	1	EA	\$	\$
15	"25" Legend (Preformed Thermo)	4	EA	\$	\$
16	"Ahead Legend (Preformed)	1	EA	\$	\$
17	"Bump" Legend (Preformed)	8	EA	\$	\$
18	"STOP" Legend (Preformed Thermo)	37	EA	\$	\$
19	"SLOW SCHOOL XING" Legend (Preformed Thermo)	4	EA	\$	\$
20	Sharrows (Preformed Thermo)	43	EA	\$	\$
21	"YIELD" Legend (Preformed Thermo)	2	EA	\$	\$

BID ITEM NO.	ITEM DESCRIPTION	EST. QTY.	UNIT	UNIT COST	EXTENDED TOTAL AMOUNT
22	YIELD LINE (Preformed Thermo)	9	EA	\$	\$
23	Green Bike Lane (Preformed)	30	SF	\$	\$
24	Bike Rider Symbol on Green (Preformed)	1	EA	\$	\$
25	Bike Rider Arrow on Green (Preformed)	1	EA	\$	\$
26	Parking Ts (Thermo)	14	EA	\$	\$

* Final Pay Quantity

TOTAL BASE BID: Items 1 through _____ inclusive: \$ _____

Note: The amount entered as the "Total Base Bid" should be identical to the Base Bid amount entered in Section 1 of the Bid Proposal form.

BIDDER NAME: _____

END OF BID SCHEDULE

END OF SUBCONTRACTOR LIST

Noncollusion Declaration

TO BE EXECUTED BY BIDDER AND SUBMITTED WITH BID

The undersigned declares:

I am the _____ [title] of _____
[business name], the party making the foregoing bid.

The bid is not made in the interest of, or on behalf of, any undisclosed person, partnership, company, association, organization, or corporation. The bid is genuine and not collusive or sham. The bidder has not directly or indirectly induced or solicited any other bidder to put in a false or sham bid. The bidder has not directly or indirectly colluded, conspired, connived, or agreed with any bidder or anyone else to put in a sham bid, or to refrain from bidding. The bidder has not in any manner, directly or indirectly, sought by agreement, communication, or conference with anyone to fix the bid price of the bidder or any other bidder, or to fix any overhead, profit, or cost element of the bid price, or of that of any other bidder. All statements contained in the bid are true. The bidder has not, directly or indirectly, submitted his or her bid price or any breakdown thereof, or the contents thereof, or divulged information or data relative thereto, to any corporation, partnership, company, association, organization, bid depository, or to any member or agent thereof, to effectuate a collusive or sham bid, and has not paid and will not pay, any person or entity for such purpose.

Any person executing this declaration on behalf of a bidder that is a corporation, partnership, joint venture, limited liability company, limited liability partnership, or any other entity, hereby represents that he or she has full power to execute, and does execute, this declaration on behalf of the bidder.

This declaration is intended to comply with California Public Contract Code § 7106 and Title 23 U.S.C § 112.

I declare under penalty of perjury under the laws of the State of California that the foregoing is true and correct and that this declaration is executed on _____ [date], at _____ [city], _____ [state].

s/ _____

Name [print]

END OF NONCOLLUSION DECLARATION

Bid Bond

_____ (“Bidder”) has submitted a bid, dated _____, 20____ (“Bid”), to the City of Cupertino (“City”) for work on the **2025 Slurry Seal / Fog Seal Project** (“Project”). Under this duly executed bid bond (“Bid Bond”), Bidder as Principal and _____, its surety (“Surety”), are bound to City as obligee in the penal sum of ten percent of the maximum amount of the Bid (the “Bond Sum”). Bidder and Surety bind themselves and their respective heirs, executors, administrators, successors and assigns, jointly and severally, as follows:

1. **General.** If Bidder is awarded the Contract for the Project, Bidder will enter into the Contract with City in accordance with the terms of the Bid.
2. **Submittals.** Within ten days following issuance of the Notice of Potential Award to Bidder, Bidder must submit to City the following:
 - 2.1 **Contract.** The executed Contract, using the form provided by City in the Project contract documents (“Contract Documents”);
 - 2.2 **Payment Bond.** A payment bond for 100% of the maximum Contract Price, executed by a surety licensed to do business in the State of California using the Payment Bond form included with the Contract Documents;
 - 2.3 **Performance Bond.** A performance bond for 100% of the maximum Contract Price, executed by a surety licensed to do business in the State of California using the Performance Bond form included with the Contract Documents;
 - 2.4 **Insurance.** The insurance certificate(s) and endorsement(s) required by the Contract Documents;
 - 2.5 **Certificates of Reported Compliance.** Valid Certificates of Reported Compliance for its fleet and its listed Subcontractors, if applicable, in accordance with the In-Use Off-Road Diesel-Fueled Fleets Regulation (13 CCR § 2449 et seq.) (“Off-Road Regulation”), if the Project involves the use of vehicles subject to the Off-Road Regulation; and any other documents required by the Instructions to Bidders or Notice of Potential Award.
3. **Enforcement.** If Bidder fails to execute the Contract or to submit the bonds, insurance certificates, and valid Certificates of Reported Compliance as required by the Contract Documents, Surety guarantees that Bidder forfeits the Bond Sum to City. Any notice to Surety may be given in the manner specified in the Contract and delivered or transmitted to Surety as follows:

Attn: _____
Address: _____
City/State/Zip: _____
Phone: _____
Fax: _____
Email: _____

4. **Duration and Waiver.** If Bidder fulfills its obligations under Section 2, above, then this obligation will be null and void; otherwise, it will remain in full force and effect for 60 days following the bid opening or until this Bid Bond is returned to Bidder, whichever occurs first. Surety waives the provisions of Civil Code §§ 2819 and 2845.

This Bid Bond is entered into and effective on _____, 20_____.

SURETY:

Business Name

s/ _____

Date

Name, Title

(Attach Acknowledgment with Notary Seal and Power of Attorney)

BIDDER:

Business Name

s/ _____

Date

Name, Title

END OF BID BOND

Bidder's Questionnaire

2025 Slurry Seal / Fog Seal Project

Within 48 hours following a request by City, a bidder must submit to City a completed, signed Bidder's Questionnaire using this form and all required attachments, including clearly labeled additional sheets as needed. City may request the Questionnaire from one or more of the apparent low bidders following the bid opening and may use the completed Questionnaire as part of its investigation to evaluate a bidder's qualifications for this Project. The Questionnaire must be filled out completely, accurately, and legibly. Any errors, omissions, or misrepresentations in completion of the Questionnaire may be grounds for rejection of the bid or termination of a Contract awarded pursuant to the bid.

Part A: General Information

Bidder Business Name	
Main Office Address and Phone	
Local Office Address and Phone	
Website Address	
Owner of Business	
Contact Name and Title	
Contact Phone and Email	
Bidder's California Contractor's License Number(s):	
Bidder's DIR Registration Number	

Check One:

	Corporation - State of incorporation:
	Partnership
	Sole Proprietorship
	Joint Venture of:
	Other:

Part B: Bidder Experience

1	How many years has Bidder been in business under its present business name? (<i>in years</i>)	
2	Has Bidder completed projects similar in type and size to this Project as a general contractor? (<i>Yes or No</i>)	

3	<p>Has Bidder ever been disqualified from a bid on grounds that it is not responsible, or otherwise disqualified or debarred from bidding under state or federal law? <i>(Yes or No)</i></p> <p>If yes, provide additional information on a <i>separate sheet</i> regarding the disqualification or debarment, including the name and address of the agency or owner of the project, the type and size of the project, the reasons that Bidder was disqualified or debarred, and the month and year in which the disqualification or debarment occurred.</p>	
4	<p>Has Bidder ever been terminated for cause, alleged default, or legal violation from a construction project, either as a general contractor or as a subcontractor? <i>(Yes or No)</i></p> <p>If yes, provide additional information on a <i>separate sheet</i> regarding the termination, including the name and address of the agency or owner of the subject project, the type and size of the project, whether Bidder was under contract as a general contractor or a subcontractor, the reasons that Bidder was terminated, and the month and year in which the termination occurred.</p>	

Part C: Project Experience

Provide information on at least three projects, performed as general contractor, that are similar in scope and character to this project. Three of the projects must be public sector projects. *(Use separate sheets if required)*

Project #1

A	Project name	
B	Project location	
C	Project description:	
D	Client/Owner (name, address, email, and phone number)	
E	Prime contractor, if applicable (name, address, email, and phone number)	
F	Architect or engineer (name, email, and phone number)	
G	Project and/or construction manager (name, email, and phone number)	
H	Scope of work performed (as general contractor or as subcontractor)	
I	Initial contract price	\$
J	Final contract price (including change orders)	\$
K	Original scheduled completion date	
L	Actual date of completion	
M	Time extensions granted (number of days)	
N	Number and amount of stop notices or mechanic's liens filed	
O	Amount of any liquidated damages assessed against Bidder	
P	Nature and resolution of any project-related claim, lawsuit, mediation, or arbitration involving Bidder	
Q	Other Notes	

Project #2

A	Project name	
B	Project location	
C	Project description:	
D	Client/Owner (name, address, email, and phone number)	
E	Prime contractor, if applicable (name, address, email, and phone number)	
F	Architect or engineer (name, email, and phone number)	
G	Project and/or construction manager (name, email, and phone number)	
H	Scope of work performed (as general contractor or as subcontractor)	
I	Initial contract price	\$
J	Final contract price (including change orders)	\$
K	Original scheduled completion date	
L	Actual date of completion	
M	Time extensions granted (number of days)	
N	Number and amount of stop notices or mechanic's liens filed	
O	Amount of any liquidated damages assessed against Bidder	
P	Nature and resolution of any project-related claim, lawsuit, mediation, or arbitration involving Bidder	
Q	Other Notes	

Project #3

A	Project name	
B	Project location	
C	Project description:	
D	Client/Owner (name, address, email, and phone number)	
E	Prime contractor, if applicable (name, address, email, and phone number)	
F	Architect or engineer (name, email, and phone number)	
G	Project and/or construction manager (name, email, and phone number)	
H	Scope of work performed (as general contractor or as subcontractor)	
I	Initial contract price	\$
J	Final contract price (including change orders)	\$
K	Original scheduled completion date	
L	Actual date of completion	
M	Time extensions granted (number of days)	
N	Number and amount of stop notices or mechanic's liens filed	
O	Amount of any liquidated damages assessed against Bidder	
P	Nature and resolution of any project-related claim, lawsuit, mediation, or arbitration involving Bidder	
Q	Other Notes	

Part D: Safety

1. Provide Bidder's Experience Modification Rate (EMR) for the last three years:

Year	EMR

2. Complete the following, based on information provided in Bidder's CalOSHA Form 300 or Form 300A, Annual Summary of Work-Related Illnesses and Injuries, from the most recent past calendar year:

2.1	Number of lost workday cases:	
2.2	Number of medical treatment cases:	
2.3	Number of deaths:	

3. Has Bidder ever been cited, fined, or prosecuted by any local, state, or federal agency, including OSHA, CalOSHA, or EPA, for violation of any law, regulation, or requirements pertaining to health and safety?

Yes or No?	
------------	--

If yes, provide additional information on a separate sheet regarding each such citation, fine, or prosecution, including the name and address of the agency or owner of the project, the type and size of the project, the reasons for and nature of the citation, fine, or prosecution, and the month and year in which the incident giving rise to the citation, fine, or prosecution occurred.

4. Name, title, and email for person responsible for Bidder's safety program:

Name	Title	Email Address

Part D: Verification

In signing this document, I, the undersigned, declare that I am duly authorized to sign and submit this Bidder's Questionnaire on behalf of the named Bidder, and that all responses and information set forth in this Bidder's Questionnaire and accompanying attachments are, to the best of my knowledge, true, accurate and complete as of the date of submission. **I declare under penalty of perjury under the laws of the State of California that the foregoing is true and correct.**

Signature: _____ Date: _____

By: _____
Name and Title

END OF BIDDER'S QUESTIONNAIRE

Contract

This public works contract ("Contract") is entered into by and between the City of Cupertino ("City") and _____ ("Contractor"), for work on the **2025 Slurry Seal / Fog Seal Project** ("Project").

The parties agree as follows:

1. **Award of Contract.** In response to the Notice Inviting Bids, Contractor has submitted a Bid Proposal to perform the Work to construct the Project. On _____, 20____, City authorized award of this Contract to Contractor for the amount set forth in Section 4, below. City has elected to include the following Project alternate(s) in the Contract:
2. **Contract Documents.** The Contract Documents incorporated into this Contract include and are comprised of all of the documents listed below. The definitions provided in Article 1 of the General Conditions apply to all of the Contract Documents, including this Contract.
 - 2.1 Notice Inviting Bids;
 - 2.2 Instructions to Bidders;
 - 2.3 Addenda, if any;
 - 2.4 Bid Proposal and attachments thereto;
 - 2.5 Contract;
 - 2.6 Payment and Performance Bonds;
 - 2.7 General Conditions;
 - 2.8 Special Conditions;
 - 2.9 Project Plans and Specifications;
 - 2.10 Change Orders, if any;
 - 2.11 Notice of Potential Award;
 - 2.12 Notice to Proceed; and
 - 2.13 The following: Caltrans Standard Details, Location Map, Truck Traffic Restrictions Map, Cupertino Unified School District Calendar, Attachment A – Authorized Lane Closure Hours
3. **Contractor's Obligations.** Contractor will perform all of the Work required for the Project, as specified in the Contract Documents. Contractor must provide, furnish, and supply all things necessary and incidental for the timely performance and completion of the Work, including all necessary labor, materials, supplies, tools, equipment, transportation, onsite facilities, and utilities, unless otherwise specified in the Contract Documents. Contractor must use its best efforts to diligently prosecute and complete the Work in a professional and expeditious manner and to meet or exceed the performance standards required by the Contract Documents.
4. **Payment.** As full and complete compensation for Contractor's timely performance and completion of the Work in strict accordance with the terms and conditions of the Contract Documents, City will pay Contractor \$_____ ("Contract Price") for all of Contractor's direct and indirect costs to perform the Work, including all labor, materials, supplies, equipment, taxes, insurance, bonds and all overhead costs, in accordance with the payment provisions in the General Conditions.
5. **Time for Completion.** Contractor will fully complete the Work for the Project, meeting all requirements for Final Completion, within 70> calendar days from the start date set forth in the Notice to Proceed ("Contract Time"). By signing below, Contractor expressly waives any claim for delayed early completion.

- 6. Liquidated Damages.** As further specified in Section 5.4 of the General Conditions, if Contractor fails to complete the Work within the Contract Time, City will assess liquidated damages in the amount of \$1,500 per day for each day of unexcused delay in achieving Final Completion, and such liquidated damages may be deducted from City's payments due or to become due to Contractor under this Contract.
- 7. Labor Code Compliance.**
- 7.1 General.** This Contract is subject to all applicable requirements of Chapter 1 of Part 7 of Division 2 of the Labor Code, including requirements pertaining to wages, working hours and workers' compensation insurance, as further specified in Article 9 of the General Conditions.
- 7.2 Prevailing Wages.** This Project is subject to the prevailing wage requirements applicable to the locality in which the Work is to be performed for each craft, classification or type of worker needed to perform the Work, including employer payments for health and welfare, pension, vacation, apprenticeship and similar purposes. Copies of these prevailing rates are available online at <http://www.dir.ca.gov/DLSR>.
- 7.3 DIR Registration.** City may not enter into the Contract with a bidder without proof that the bidder and its Subcontractors are registered with the California Department of Industrial Relations to perform public work pursuant to Labor Code § 1725.5, subject to limited legal exceptions.
- 8. Workers' Compensation Certification.** Pursuant to Labor Code § 1861, by signing this Contract, Contractor certifies as follows: "I am aware of the provisions of Labor Code § 3700 which require every employer to be insured against liability for workers' compensation or to undertake self-insurance in accordance with the provisions of that code, and I will comply with such provisions before commencing the performance of the Work on this Contract."
- 9. Conflicts of Interest.** Contractor, its employees, Subcontractors, and agents may not have, maintain, or acquire a conflict of interest in relation to this Contract in violation of any City ordinance or requirement, or in violation of any California law, including Government Code § 1090 et seq., or the Political Reform Act, as set forth in Government Code § 81000 et seq. and its accompanying regulations. Any violation of this Section constitutes a material breach of the Contract.
- 10. Independent Contractor.** Contractor is an independent contractor under this Contract and will have control of the Work and the means and methods by which it is performed. Contractor and its Subcontractors are not employees of City and are not entitled to participate in any health, retirement, or any other employee benefits from City.
- 11. Notice.** Any notice, billing, or payment required by or pursuant to the Contract Documents must be made in writing, signed, dated, and sent to the other party by personal delivery, U.S. Mail, a reliable overnight delivery service, or by email as a PDF file. Notice is deemed effective upon delivery, except that service by U.S. Mail is deemed effective on the second working day after deposit for delivery. Notice for each party must be given as follows:

City:

Public Works	<i>Department</i>
10300 Torre Ave	<i>Address</i>
Cupertino, CA 95014	<i>City/State/Zip</i>

408-777-3245	<i>Phone</i>
Attn: Jo Anne Johnson	<i>Contact name</i>
joannej@cupertino.org	<i>Contact email address</i>
Copy to: PW Invoices	<i>CC Contact name</i>
pwinvoices@cupertino.org	<i>CC Contact email address</i>

Contractor:

	<i>Name</i>
	<i>Address</i>
	<i>City/State/Zip</i>
	<i>Phone</i>
Attn:	<i>Contact name</i>
	<i>Contact email address</i>
Copy to:	<i>CC Contact name</i>
	<i>CC Contact email address</i>

12. General Provisions.

- 12.1 Assignment and Successors.** Contractor may not assign its rights or obligations under this Contract, in part or in whole, without City's written consent. This Contract is binding on Contractor's and City's lawful heirs, successors and permitted assigns.
- 12.2 Third Party Beneficiaries.** There are no intended third-party beneficiaries to this Contract.
- 12.3 Governing Law and Venue.** This Contract will be governed by California law and venue will be in the Santa Clara County Superior Court, and no other place. Contractor waives any right it may have pursuant to Code of Civil Procedure § 394, to file a motion to transfer any action arising from or relating to this Contract to a venue outside of Santa Clara County, California.
- 12.4 Amendment.** No amendment or modification of this Contract will be binding unless it is in a writing duly authorized and signed by the parties to this Contract.
- 12.5 Integration.** This Contract and the Contract Documents incorporated herein, including authorized amendments or Change Orders thereto, constitute the final, complete, and exclusive terms of the agreement between City and Contractor.
- 12.6 Severability.** If any provision of the Contract Documents is determined to be illegal, invalid, or unenforceable, in whole or in part, the remaining provisions of the Contract Documents will remain in full force and effect.
- 12.7 Iran Contracting Act.** If the Contract Price exceeds \$1,000,000, Contractor certifies, by signing below, that it is not identified on a list created under the Iran Contracting Act, Public Contract Code § 2200 et seq. (the "Act"), as a person engaging in investment activities in Iran, as defined in the Act, or is otherwise expressly exempt under the Act.
- 12.8 Authorization.** Each individual signing below warrants that he or she is authorized to do so by the party that he or she represents, and that this Contract is legally

binding on that party. If Contractor is a corporation, signatures from two officers of the corporation are required pursuant to California Corporations Code § 313.

[Signatures are on the following page.]

The parties agree to this Contract as witnessed by the signatures below:

CITY:

Approved as to form:

s/ _____

s/ _____

Name, Title

Name, Title

Date: _____

Date: _____

Attest:

s/ _____

Name, Title

Date: _____

CONTRACTOR: _____
Business Name

s/ _____

Seal:

Name, Title

Date: _____

Second Signature (See Section 12.8):

s/ _____

Name, Title

Date: _____

Contractor's California License Number(s) and Expiration Date(s)

END OF CONTRACT

Payment Bond

The City of Cupertino ("City") and _____ ("Contractor") have entered into a contract for work on the **2025 Slurry Seal / Fog Seal Project** ("Project"). The Contract is incorporated by reference into this Payment Bond ("Bond").

- 1. General.** Under this Bond, Contractor as principal and _____, its surety ("Surety"), are bound to City as obligee in an amount not less than \$_____, under California Civil Code § 9550 et seq., to ensure payment to authorized claimants. This Bond is binding on the respective successors, assigns, owners, heirs, or executors of Surety and Contractor.
- 2. Surety's Obligation.** If Contractor or any of its Subcontractors fails to pay a person authorized in California Civil Code § 9100 to assert a claim against a payment bond, any amounts due under the Unemployment Insurance Code with respect to work or labor performed under the Contract, or any amounts required to be deducted, withheld, and paid over to the Employment Development Department from the wages of employees of Contractor and its Subcontractors under California Unemployment Insurance Code § 13020 with respect to the work and labor, then Surety will pay the obligation.
- 3. Beneficiaries.** This Bond inures to the benefit of any of the persons named in California Civil Code § 9100, so as to give a right of action to those persons or their assigns in any suit brought upon this Bond. Contractor must promptly provide a copy of this Bond upon request by any person with legal rights under this Bond.
- 4. Duration.** If Contractor promptly makes payment of all sums for all labor, materials, and equipment furnished for use in the performance of the Work required by the Contract, in conformance with the time requirements set forth in the Contract and as required by California law, Surety's obligations under this Bond will be null and void. Otherwise, Surety's obligations will remain in full force and effect.
- 5. Waivers.** Surety waives any requirement to be notified of alterations to the Contract or extensions of time for performance of the Work under the Contract. Surety waives the provisions of Civil Code §§ 2819 and 2845. City waives the requirement of a new bond for any supplemental contract under Civil Code § 9550. Any notice to Surety may be given in the manner specified in the Contract and sent to Surety as follows:

Attn: _____
Address: _____
City/State/Zip: _____
Phone: _____
Email: _____

- 6. Law and Venue.** This Bond will be governed by California law, and venue for any dispute pursuant to this Bond will be in the Santa Clara County Superior Court, and no other place. Surety will be responsible for City's attorneys' fees and costs in any action to enforce the provisions of this Bond.

[Signatures are on the following page.]

7. **Effective Date; Execution.** This Bond is entered into and is effective on _____, 2025.

SURETY:

Business Name

s/ _____

Date

Name, Title

(Attach Acknowledgment with Notary Seal and Power of Attorney)

CONTRACTOR:

Business Name

s/ _____

Date

Name, Title

APPROVED BY CITY:

s/ _____

Date

Name, Title

END OF PAYMENT BOND

Performance Bond

The City of Cupertino ("City") and _____ ("Contractor") have entered into a contract for work on the **2025 Slurry Seal / Fog Seal Project** ("Project"). The Contract is incorporated by reference into this Performance Bond ("Bond").

1. **General.** Under this Bond, Contractor as principal and _____, its surety ("Surety"), are bound to City as obligee for an amount not less than \$_____ to ensure Contractor's faithful performance of its obligations under the Contract. This Bond is binding on the respective successors, assigns, owners, heirs, or executors of Surety and Contractor.
2. **Surety's Obligations.** Surety's obligations are co-extensive with Contractor's obligations under the Contract. If Contractor fully performs its obligations under the Contract, including its warranty obligations under the Contract, Surety's obligations under this Bond will become null and void. Otherwise, Surety's obligations will remain in full force and effect.
3. **Waiver.** Surety waives any requirement to be notified of and further consents to any alterations to the Contract made under the applicable provisions of the Contract Documents, including changes to the scope of Work or extensions of time for performance of Work under the Contract. Surety waives the provisions of Civil Code §§ 2819 and 2845.
4. **Application of Contract Balance.** Upon making a demand on this Bond for completion of the Work prior to acceptance of the Project, City will make the Contract Balance available to Surety for completion of the Work under the Contract. For purposes of this provision, the Contract Balance is defined as the total amount payable by City to Contractor as the Contract Price minus amounts already paid to Contractor, and minus any liquidated damages, credits, or backcharges to which City is entitled under the terms of the Contract.
5. **Contractor Default.** Upon written notification from City of Contractor's termination for default under Article 13 of the Contract General Conditions, time being of the essence, Surety must act within the time specified in Article 13 to remedy the default through one of the following courses of action:
 - 5.1 Arrange for completion of the Work under the Contract by Contractor, with City's consent, but only if Contractor is in default solely due to its financial inability to complete the Work;
 - 5.2 Arrange for completion of the Work under the Contract by a qualified contractor acceptable to City, and secured by performance and payment bonds issued by an admitted surety as required by the Contract Documents, at Surety's expense; or
 - 5.3 Waive its right to complete the Work under the Contract and reimburse City the amount of City's costs to have the remaining Work completed.
6. **Surety Default.** If Surety defaults on its obligations under the Bond, City will be entitled to recover all costs it incurs due to Surety's default, including legal, design professional, or delay costs.
7. **Notice.** Any notice to Surety may be given in the manner specified in the Contract and sent to Surety as follows:

Attn: _____

Address: _____

City/State/Zip: _____
Phone: _____
Fax: _____
Email: _____

8. **Law and Venue.** This Bond will be governed by California law, and venue for any dispute pursuant to this Bond will be in the Santa Clara County Superior Court, and no other place. Surety will be responsible for City's attorneys' fees and costs in any action to enforce the provisions of this Bond.
9. **Effective Date; Execution.** This Bond is entered into and effective on _____, 2025.

SURETY:

Business Name

s/ _____

Date

Name, Title

(Attach Acknowledgment with Notary Seal and Power of Attorney)

CONTRACTOR:

Business Name

s/ _____

Date

Name, Title

APPROVED BY CITY:

s/ _____

Date

Name, Title

END OF PERFORMANCE BOND

General Conditions

Article 1 - Definitions

Definitions. The following definitions apply to all of the Contract Documents unless otherwise indicated, e.g., additional definitions that apply solely to the Specifications or other technical documents. Defined terms and titles of documents are capitalized in the Contract Documents, with the exception of the following (in any tense or form): “day,” “furnish,” “including,” “install,” “work day,” or “working day.”

Allowance means a specific amount that must be included in the Bid Proposal for a specified purpose.

Article, as used in these General Conditions, means a numbered Article of the General Conditions, unless otherwise indicated by the context.

Change Order means a written document duly approved and executed by City, which changes the scope of Work, the Contract Price, or the Contract Time.

City means the municipality which has entered into the Contract with Contractor for performance of the Work, acting through its City Council, officers, employees, City Engineer, and any other authorized representatives.

City Engineer means the City Engineer for City and his or her authorized delegee(s).

Claim means a separate demand by Contractor for a change in the Contract Time or Contract Price, that has previously been submitted to City in accordance with the requirements of the Contract Documents, and which has been rejected by City, in whole or in part; a written demand by Contractor disputing a unilateral Change Order or a portion thereof; or a written demand by Contractor objecting to the amount of Final Payment.

Contract means the signed agreement between City and Contractor for performing the Work required for the Project, and all documents expressly incorporated therein.

Contract Documents means, collectively, all of the documents listed as such in Section 2 of the Contract, including the Notice Inviting Bids; the Instructions to Bidders; addenda, if any; the Bid Proposal and attachments thereto; the Contract; the Notice of Potential Award and Notice to Proceed; the payment and performance bonds; the General Conditions; the Special Conditions; the Project Plans and Specifications; any Change Orders; and any other documents which are clearly and unambiguously made part of the Contract Documents. The Contract Documents do not include documents provided “For Reference Only,” or documents that are intended solely to provide information regarding existing conditions.

Contract Price means the total compensation to be paid to Contractor for performance of the Work, as set forth in the Contract and as may be amended by Change Order or adjusted for an Allowance. The Contract Price is not subject to adjustment due to inflation or due to the increased cost of labor, material, supplies, or equipment following submission of the Bid Proposal.

Contract Time means the time specified for complete performance of the Work, as set forth in the Contract and as may be amended by Change Order.

Contractor means the individual, partnership, corporation, or joint venture that has signed the Contract with City to perform the Work.

Day means a calendar day unless otherwise specified.

Design Professional means the licensed individual(s) or firm(s) retained by City to provide architectural, engineering, or other design professional services for the Project. If no Design Professional has been retained for this Project, any reference to Design Professional is deemed to refer to the Engineer.

DIR means the California Department of Industrial Relations.

Drawings has the same meaning as Plans.

Engineer means the City Engineer for the City of Cupertino and his or her authorized delegates.

Excusable Delay is defined in Section 5.3(B), Excusable Delay.

Extra Work means new or unforeseen work added to the Project, as determined by the Engineer in his or her sole discretion, including Work that was not part of or incidental to the scope of the Work when the Contractor's bid was submitted; Work that is substantially different from the Work as described in the Contract Documents at bid time; or Work that results from a substantially differing and unforeseeable condition.

Final Completion means Contractor has fully completed all of the Work required by the Contract Documents to the City's satisfaction, including all punch list items and any required commissioning or training, and has provided the City with all required submittals, including the instructions and manuals, product warranties, and as-built drawings.

Final Payment means payment to Contractor of the unpaid Contract Price, including release of undisputed retention, less amounts withheld or deducted pursuant to the Contract Documents.

Furnish means to purchase and deliver for the Project.

Government Code Claim means a claim submitted pursuant to California Government Code § 900 et seq.

Hazardous Materials means any substance or material identified now or in the future as hazardous under any Laws, or any other substance or material that may be considered hazardous or otherwise subject to Laws governing handling, disposal, or cleanup.

Including, whether or not capitalized, means "including, but not limited to," unless the context clearly requires otherwise.

Inspector means the individual(s) or firm(s) retained or employed by City to inspect the workmanship, materials, and manner of construction of the Project and its components to ensure compliance with the Contract Documents and all Laws.

Install means to fix in place for materials, and to fix in place and connect for equipment.

Laws means all applicable local, state, and federal laws, regulations, rules, codes, ordinances, permits, orders, and the like enacted or imposed by or under the auspices of any governmental entity with jurisdiction over any of the Work or any performance of the Work, including health and safety requirements.

Non-Excusable Delay is defined in Section 5.3(D), Non-Excusable Delay.

Plans means the City-provided plans, drawings, details, or graphical depictions of the Project requirements, but does not include Shop Drawings.

Project means the public works project referenced in the Contract, as modified by any Project alternates elected by City, if any.

Project Manager means the individual designated by City to oversee and manage the Project on City's behalf and may include his or her authorized delegee(s) when the Project Manager is unavailable. If no Project Manager has been designated for this Project, any reference to Project Manager is deemed to refer to the Engineer.

Recoverable Costs is defined in Section 5.3(F), Recoverable Costs.

Request for Information or **RFI** means Contractor's written request for information about the Contract Documents, the Work or the Project, submitted to City in the manner and format specified by City.

Section, when capitalized in these General Conditions, means a numbered section or subsection of the General Conditions, unless the context clearly indicates otherwise.

Shop Drawings means drawings, plan details or other graphical depictions prepared by or on behalf of Contractor, and subject to City acceptance, which are intended to provide details for fabrication, installation, and the like, of items required by or shown in the Plans or Specifications.

Specialty Work means Work that must be performed by a specialized Subcontractor with the specified license or other special certification, and that the Contractor is not qualified to self-perform.

Specifications means the technical, text specifications describing the Project requirements, which are prepared for and incorporated into the Contract by or on behalf of City, and does not include the Contract, General Conditions or Special Conditions.

Subcontractor means an individual, partnership, corporation, or joint venture retained by Contractor directly or indirectly through a subcontract to perform a specific portion of the Work. The term Subcontractor applies to subcontractors of all tiers, unless otherwise indicated by the context. A third party such as a utility performing related work on the Project is not a Subcontractor, even if Contractor must coordinate its Work with the third party.

Technical Specifications has the same meaning as Specifications.

Work means all of the construction and services necessary for or incidental to completing the Project in conformance with the requirements of the Contract Documents.

Work Day or **Working Day**, whether or not capitalized, means a weekday when the City is open for business, and does not include holidays observed by the City.

Holidays observed by the City and furlough days are:

- a. New Year's Day, January 1;
- b. Martin Luther King Jr.'s Birthday, third Monday in January;
- c. Lunar New Year, date varies, approximately the first week in February;
- d. Presidents' Day, third Monday in February;
- e. Cesar Chavez Day, March 31 or April 1 observed
- f. Memorial Day, last Monday in May;
- g. Juneteenth, June 19
- h. Independence Day, July 4;

- i. Labor Day, first Monday in September;
- j. Veterans' Day, November 11;
- k. Thanksgiving Day, as designated by the President;
- l. The Day following Thanksgiving Day;
- m. Christmas Day, December 25;
- n. City Closure, December 24, 26, 27,28,29,30 and 31: and each day appointed by the Governor of California and formally recognized by the Santa Clara County Board of Supervisors as a day of mourning, thanksgiving, or special observance.

Worksite means the place or places where the Work is performed, which includes, but may extend beyond the Project site, including separate locations for staging, storage, or fabrication.

Article 2 - Roles and Responsibilities

2.1 City.

(A) **City Council.** The City Council has final authority in all matters affecting the Project, except to the extent it has delegated authority to the Engineer.

(B) **Engineer.** The Engineer, acting within the authority conferred by the City Council, is responsible for administration of the Project on behalf of City, including authority to provide directions to the Design Professional and to Contractor to ensure proper and timely completion of the Project. The Engineer's decisions are final and conclusive within the scope of his or her authority, including interpretation of the Contract Documents.

(C) **Project Manager.** The Project Manager assigned to the Project will be the primary point of contact for the Contractor and will serve as City's representative for daily administration of the Project on behalf of City. Unless otherwise specified, all of Contractor's communications to City (in any form) will go to or through the Project Manager. City reserves the right to reassign the Project Manager role at any time or to delegate duties to additional City representatives, without prior notice to or consent of Contractor.

(D) **Design Professional.** The Design Professional is responsible for the overall design of the Project and, to the extent authorized by City, may act on City's behalf to ensure performance of the Work in compliance with the Plans and Specifications, including any design changes authorized by Change Order. The Design Professional's duties may include review of Contractor's submittals, visits to any Worksite, inspecting the Work, evaluating test and inspection results, and participation in Project-related meetings, including any pre-construction conference, weekly meetings, and coordination meetings. The Design Professional's interpretation of the Plans or Specifications is final and conclusive.

2.2 Contractor.

(A) **General.** Contractor must provide all labor, materials, supplies, equipment, services, and incidentals necessary to perform and timely complete the Work in strict accordance with the Contract Documents, and in an economical and efficient manner in the best interests of City, and with minimal inconvenience to the public.

(B) **Responsibility for the Work and Risk of Loss.** Contractor is responsible for supervising and directing all aspects of the Work to facilitate the efficient and timely completion of the Work. Contractor is solely responsible for and required to exercise full control over the Work, including the construction means, methods, techniques, sequences, procedures, safety precautions and programs, and coordination of all portions of the Work with that of all other contractors and Subcontractors, except to the extent that the Contract Documents provide other specific instructions. Contractor's responsibilities extend to any plan, method or sequence suggested, but not required by City or specified in the Contract Documents. From the date of commencement of the Work until either the date on which City formally accepts the Project or the effective date of termination of the Contract, whichever is later, Contractor bears all risks of injury or damage to the Work and the materials and equipment delivered to any Worksite, by any cause including fire, earthquake, wind, weather, vandalism, or theft, subject to the limitations of Laws, including Public Contract Code § 7105.

(C) **Project Administration.** Contractor must provide sufficient and competent administration, staff, and skilled workforce necessary to perform and timely complete the Work in accordance with the Contract Documents. Before starting the Work, Contractor must designate in writing and provide complete contact information, including telephone numbers and email address, for the officer or employee in Contractor's organization who is to serve as Contractor's primary representative for the Project, and who has authority to act on Contractor's behalf. A Subcontractor may not serve as Contractor's primary representative.

(D) **On-Site Superintendent.** Contractor must, at all times during performance of the Work, provide a qualified and competent full-time superintendent acceptable to City, and assistants as necessary, who must be physically present at the Project site while any aspect of the Work is being performed. The superintendent must have full authority to act and communicate on behalf of Contractor, and Contractor will be bound by the superintendent's communications to City. City's approval of the superintendent is required before the Work commences. If City is not satisfied with the superintendent's performance, City may request a qualified replacement of the superintendent. Failure to comply may result in temporary suspension of the Work, at Contractor's sole expense and with no extension of Contract Time, until an approved superintendent is physically present to supervise the Work. Contractor must provide written notice to City, as soon as practicable, before replacing the superintendent.

(E) **Standards.** Contractor must, at all times, ensure that the Work is performed in an efficient, skillful manner following best practices and in full compliance with the Contract Documents, Laws, and applicable manufacturer's recommendations. Contractor has a material and ongoing obligation to provide true and complete information, to the best of its knowledge, with respect to all records, documents, or communications pertaining to the Project, including oral or written reports, statements, certifications, Change Order requests, or Claims.

(F) **Meetings.** Contractor, its project manager, superintendent and any primary Subcontractors requested by City, must attend a pre-construction conference, if requested by City, as well as weekly Project progress meetings scheduled with City. If applicable, Contractor may also be required to participate in coordination meetings with other parties relating to other work being performed on or near the Project site or in relation to the Project, including work or activities performed by City, other contractors, or other utility owners.

(G) **Construction Records.** Contractor will maintain up-to-date, thorough, legible, and dated daily job reports, which document all significant activity on the Project for each day that Work is performed on the Project. The daily report for each day must include the

number of workers at the Project site; primary Work activities; major deliveries; problems encountered, including injuries, if any; weather and site conditions; and delays, if any. Contractor will take date and time-stamped photographs to document general progress of the Project, including site conditions prior to construction activities, before and after photographs at offset trench laterals, existing improvements and utilities, damage and restoration. Contractor will maintain copies of all subcontracts, Project-related correspondence with Subcontractors, and records of meetings with Subcontractors. Upon request by the City, Contractor will permit review of and/or provide copies of any of these construction records.

(H) **Responsible Party.** Contractor is solely responsible to City for the acts or omissions of any Subcontractors, or any other party or parties performing portions of the Work or providing equipment, materials or services for or on behalf of Contractor or the Subcontractors. Upon City's written request, Contractor must promptly and permanently remove from the Project, at no cost to City, any employee or Subcontractor or employee of a Subcontractor who the Engineer has determined to be incompetent, intemperate or disorderly, or who has failed or refused to perform the Work as required under the Contract Documents.

(I) **Correction of Defects.** Contractor must promptly correct, at Contractor's sole expense, any Work that is determined by City to be deficient or defective in any way, including workmanship, materials, parts, or equipment. Workmanship, materials, parts, or equipment that do not conform to the requirements under the Contract Documents, as determined by City, will be considered defective and subject to rejection. Contractor must also promptly correct, at Contractor's sole expense, any Work performed beyond the lines and grades shown on the Plans or established by City, and any Extra Work performed without City's prior written approval. If Contractor fails to correct or to take reasonable steps toward correcting defective Work within five days following notice from City, or within the time specified in City's notice to correct, City may elect to have the defective Work corrected by its own forces or by a third party, in which case the cost of correction will be deducted from the Contract Price. If City elects to correct defective Work due to Contractor's failure or refusal to do so, City or its agents will have the right to take possession of and use any equipment, supplies, or materials available at the Project site or any Worksite on City property, in order to effectuate the correction, at no extra cost to City. Contractor's warranty obligations under Section 11.2, Warranty, will not be waived nor limited by City's actions to correct defective Work under these circumstances. Alternatively, City may elect to retain defective Work, and deduct the difference in value, as determined by the Engineer, from payments otherwise due to Contractor. This paragraph applies to any defective Work performed by Contractor during the one-year warranty period under Section 11.2.

(J) **Contractor's Records.** Contractor must maintain all of its records relating to the Project in any form, including paper documents, photos, videos, electronic records, approved samples, and the construction records required pursuant to paragraph (G), above. Project records subject to this provision include complete Project cost records and records relating to preparation of Contractor's bid, including estimates, take-offs, and price quotes or bids.

(1) Contractor's cost records must include all supporting documentation, including original receipts, invoices, and payroll records, evidencing its direct costs to perform the Work, including, but not limited to, costs for labor, materials, and equipment. Each cost record should include, at a minimum, a description of the expenditure with references to the applicable requirements of the Contract Documents, the amount actually paid, the date of payment, and whether the expenditure is part of the original Contract Price, related to an executed Change Order, or otherwise categorized by Contractor as Extra Work. Contractor's failure

to comply with this provision as to any claimed cost operates as a waiver of any rights to recover the claimed cost.

(2) Contractor must continue to maintain its Project-related records in an organized manner for a period of five years after City's acceptance of the Project or following Contract termination, whichever occurs first. Subject to prior notice to Contractor, City is entitled to inspect or audit any of Contractor's records relating to the Project during Contractor's normal business hours. Contractor's records may also be subject to examination and audit by the California State Auditor, pursuant to Government Code § 8546.7. The record-keeping requirements set forth in this subsection 2.2(J) will survive expiration or termination of the Contract.

(K) **Copies of Project Documents.** Contractor and its Subcontractors must keep copies, at the Project site, of all Work-related documents, including the Contract, permit(s), Plans, Specifications, addenda, Contract amendments, Change Orders, RFIs and RFI responses, Shop Drawings, as-built drawings, schedules, daily records, testing and inspection reports or results, and any related written interpretations. These documents must be available to City for reference at all times during construction of the Project.

2.3 Subcontractors.

(A) **General.** All Work which is not performed by Contractor with its own forces must be performed by Subcontractors. City reserves the right to approve or reject any and all Subcontractors proposed to perform the Work, for reasons including the Subcontractor's poor reputation, lack of relevant experience, financial instability, and lack of technical ability or adequate trained workforce. Each Subcontractor must obtain a City business license before performing any Work.

(B) **Contractual Obligations.** Contractor must require each Subcontractor to comply with the provisions of the Contract Documents as they apply to the Subcontractor's portion(s) of the Work, including the generally applicable terms of the Contract Documents, and to likewise bind their subcontractors. Contractor will provide that the rights that each Subcontractor may have against any manufacturer or supplier for breach of warranty or guarantee relating to items provided by the Subcontractor for the Project, will be assigned to City. Nothing in these Contract Documents creates a contractual relationship between a Subcontractor and City, but City is deemed to be a third-party beneficiary of the contract between Contractor and each Subcontractor.

(C) **Termination.** If the Contract is terminated, each Subcontractor's agreement must be assigned by Contractor to City, subject to the prior rights of any surety, but only if and to the extent that City accepts, in writing, the assignment by written notification, and assumes all rights and obligations of Contractor pursuant to each such subcontract agreement.

(D) **Substitution of Subcontractor.** If Contractor requests substitution of a listed Subcontractor under Public Contract Code § 4107, Contractor is solely responsible for all costs City incurs in responding to the request, including legal fees and costs to conduct a hearing, and any increased subcontract cost to perform the Work that was to be performed by the listed Subcontractor. If City determines that a Subcontractor is unacceptable to City based on the Subcontractor's failure to satisfactorily perform its Work, or for any of the grounds for substitution listed in Public Contract Code § 4107(a), City may request removal of the Subcontractor from the Project. Upon receipt of a written request from City to remove a Subcontractor pursuant to this paragraph, Contractor will

immediately remove the Subcontractor from the Project and, at no further cost to City, will either (1) self-perform the remaining Work to the extent that Contractor is duly licensed and qualified to do so, or (2) substitute a Subcontractor that is acceptable to City, in compliance with Public Contract Code § 4107, as applicable.

2.4 Coordination of Work.

(A) **Concurrent Work.** City reserves the right to perform, have performed, or permit performance of other work on or adjacent to the Project site while the Work is being performed for the Project. Contractor is responsible for coordinating its Work with other work being performed on or adjacent to the Project site, including by any utility companies or agencies, and must avoid hindering, delaying, or interfering with the work of other contractors, individuals, or entities, and must ensure safe and reasonable site access and use as required or authorized by City. To the full extent permitted by law, Contractor must hold harmless and indemnify City against any and all claims arising from or related to Contractor's avoidable, negligent, or willful hindrance of, delay to, or interference with the work of any utility company or agency or another contractor or subcontractor.

(B) **Coordination.** If Contractor's Work will connect or interface with work performed by others, Contractor is responsible for independently measuring and visually inspecting such work to ensure a correct connection and interface. Contractor is responsible for any failure by Contractor or its Subcontractors to confirm measurements before proceeding with connecting Work. Before proceeding with any portion of the Work affected by the construction or operations of others, Contractor must give the Project Manager prompt written notification of any defects Contractor discovers which will prevent the proper execution of the Work. Failure to give notice of any known or reasonably discoverable defects will be deemed acknowledgement by Contractor that the work of others is not defective and will not prevent the proper execution of the Work. Contractor must also promptly notify City if work performed by others, including work or activities performed by City's own forces, is operating to hinder, delay, or interfere with Contractor's timely performance of the Work. City reserves the right to backcharge Contractor for any additional costs incurred due to Contractor's failure to comply with the requirements in this Section 2.4.

2.5 **Submittals.** Unless otherwise specified, Contractor must submit to the Engineer for review and acceptance, all schedules, Shop Drawings, samples, product data, and similar submittals required by the Contract Documents, or upon request by the Engineer. Unless otherwise specified, all submittals, including Requests for Information, are subject to the general provisions of this Section, as well as specific submittal requirements that may be included elsewhere in the Contract Documents, including the Special Conditions or Specifications. The Engineer may require submission of a submittal schedule at or before a pre-construction conference, as may be specified in the Notice to Proceed.

(A) **General.** Contractor is responsible for ensuring that its submittals are accurate and conform to the Contract Documents.

(B) **Time and Manner of Submission.** Contractor must ensure that its submittals are prepared and delivered in a manner consistent with the current City-accepted schedule for the Work and within the applicable time specified in the Contract Documents, or if no time is specified, in such time and sequence so as not to delay the performance of the Work or completion of the Project.

(C) **Required Contents.** Each submittal must include the Project name and contract number, Contractor's name and address, the name and address of any Subcontractor or

supplier involved with the submittal, the date, and references to applicable Specification section(s) and/or drawing and detail number(s).

(D) **Required Corrections.** If corrections are required, Contractor must promptly make and submit any required corrections as specified in full conformance with the requirements of this Section, or other requirements that apply to that submittal.

(E) **Effect of Review and Acceptance.** Review and acceptance of a submittal by City will not relieve Contractor from complying with the requirements of the Contract Documents. Contractor is responsible for any errors in any submittal, and review or acceptance of a submittal by City is not an assumption of risk or liability by City.

(F) **Enforcement.** Any Work performed or any material furnished, installed, fabricated or used without City's prior acceptance of a required submittal is performed or provided at Contractor's risk, and Contractor may be required to bear the costs incident thereto, including the cost of removing and replacing such Work, repairs to other affected portions of the Work or material, and the cost of additional time or services required of City, including costs for the Design Professional, Project Manager, or Inspector.

(G) **Excessive RFIs.** A RFI will be considered excessive or unnecessary if City determines that the explanation or response to the RFI is clearly and unambiguously discernable from the Contract Documents. City's costs to review and respond to excessive or unnecessary RFIs may be deducted from payments otherwise due to Contractor.

- 2.6 Shop Drawings.** When Shop Drawings are required by the Specifications or requested by the Engineer, they must be prepared according to best practices at Contractor's expense. The Shop Drawings must be of a size and scale to clearly show all necessary details. Unless otherwise specified by City, Shop Drawings must be provided to the Engineer for review and acceptance at least 30 days before the Work will be performed. If City requires changes, the corrected Shop Drawings must be resubmitted to the Engineer for review within the time specified by the Engineer. For all Project components requiring Shop Drawings, Contractor will not furnish materials or perform any Work until the Shop Drawings for those components are accepted by City. Contractor is responsible for any errors or omissions in the Shop Drawings, shop fits and field corrections; any deviations from the Contract Documents; and for the results obtained by the use of Shop Drawings. Acceptance of Shop Drawings by City does not relieve Contractor of Contractor's responsibility.
- 2.7 Access to Work.** Contractor must afford prompt and safe access to any Worksite by City and its employees, agents, or consultants authorized by City; and upon request by City, Contractor must promptly arrange for City representatives to visit or inspect manufacturing sites or fabrication facilities for items to be incorporated into the Work.
- 2.8 Personnel.** Contractor and its Subcontractors must employ only competent and skillful personnel to perform the Work. Contractor and its Subcontractor's supervisors, security or safety personnel, and employees who have unescorted access to the Project site must possess proficiency in English sufficient to read, understand, receive, and implement oral or written communications or instructions relating to their respective job functions, including safety and security requirements. Upon written notification from the Engineer, Contractor and its Subcontractors must immediately discharge any personnel who are incompetent, disorderly, disruptive, threatening, abusive, or profane, or otherwise refuse or fail to comply with the requirements of the Contract Documents or Laws, including Laws pertaining to health and safety. Any such discharged personnel may not be re-employed or permitted on the Project in any capacity without City's prior written consent.

Article 3 - Contract Documents

3.1 Interpretation of Contract Documents.

(A) **Plans and Specifications.** The Plans and Specifications included in the Contract Documents are complementary. If Work is shown on one but not on the other, Contractor must perform the Work as though fully described on both, consistent with the Contract Documents and reasonably inferable from them as being necessary to produce the indicated results. The Plans and Specifications are deemed to include and require everything necessary and reasonably incidental to completion of the Work, whether or not particularly mentioned or shown. Contractor must perform all Work and services and supply all things reasonably related to and inferable from the Contract Documents. In the event of a conflict between the Plans and Specifications, the Specifications will control, unless the drawing(s) at issue are dated later than the Specification(s) at issue. Detailed drawings take precedence over general drawings, and large-scale drawings take precedence over smaller scale drawings. Any arrangement or division of the Plans and Specifications into sections is for convenience and is not intended to limit the Work required by separate trades. A conclusion presented in the Plans or Specifications is only a recommendation. Actual locations and depths must be determined by Contractor's field investigation. Contractor may request access to underlying or background information in City's possession that is necessary for Contractor to form its own conclusions.

(B) **Duty to Notify and Seek Direction.** If Contractor becomes aware of a changed condition in the Project, or of any ambiguity, conflict, inconsistency, discrepancy, omission, or error in the Contract Documents, including the Plans or Specifications, Contractor must promptly submit a Request for Information to the Engineer and wait for a response from City before proceeding further with the related Work. The RFI must notify City of the issue and request clarification, interpretation or direction. The Engineer's clarification, interpretation or direction will be final and binding on Contractor. If Contractor proceeds with the related Work before obtaining City's response, Contractor will be responsible for any resulting costs, including the cost of correcting any incorrect or defective Work that results. Timely submission of a clear and complete RFI is essential to avoiding delay. Delay resulting from Contractor's failure to submit a timely and complete RFI to the Engineer is Non-Excusable Delay. If Contractor believes that City's response to an RFI justifies a change to the Contract Price or Contract Time, Contractor must perform the Work as directed, but may submit a timely Change Order request in accordance with the Contract Documents. (See Articles 5 and 6.)

(C) **Figures and Dimensions.** Figures control over scaled dimensions.

(D) **Technical or Trade Terms.** Any terms that have well-known technical or trade meanings will be interpreted in accordance with those meanings, unless otherwise specifically defined in the Contract Documents.

(E) **Measurements.** Contractor must verify all relevant measurements in the Contract Documents and at the Project site before ordering any material or performing any Work, and will be responsible for the correctness of those measurements or for costs that could have been avoided by independently verifying measurements.

(F) **Compliance with Laws.** The Contract Documents are intended to comply with Laws and will be interpreted to comply with Laws.

3.2 Order of Precedence.

Information included in one Contract Document but not in another will not be considered a conflict or inconsistency. Unless otherwise specified in the Special Conditions, in case of any conflict or inconsistency among the Contract

Documents, the following order of precedence will apply, beginning from highest to lowest, with the most recent version taking precedent over an earlier version:

- (A) Change Orders;
- (B) Addenda;
- (C) Contract;
- (D) Notice to Proceed;
- (E) Attachment B – Federal Contract Requirements (only if used);
- (F) Special Conditions;
- (G) General Conditions;
- (H) Payment and Performance Bonds;
- (I) Specifications;
- (J) Plans;
- (K) Notice of Potential Award;
- (L) Notice Inviting Bids;
- (M) Attachment A – Federal Bidding Requirements (only if used);
- (N) Instructions to Bidders;
- (O) Contractor’s Bid Proposal and attachments;
- (P) the City’s standard specifications, as applicable; and
- (Q) Any generic documents prepared by and on behalf of a third party, that were not prepared specifically for this Project, such as the Caltrans Standard Specifications or Caltrans Special Provisions.

3.3 Caltrans Standard Specifications. Any reference to or incorporation of the Standard Specifications of the State of California, Department of Transportation (“Caltrans”), including “Standard Specifications,” “Caltrans Specifications,” “State Specifications,” or “CSS,” means the most current edition of Caltrans’ Standard Specifications, unless otherwise specified (“Caltrans Standard Specifications”), including the most current amendments as of the date that Contractor’s bid was submitted for this Project. The following provisions apply to use of or reference to the Caltrans Standard Specifications or Special Provisions:

(A) **Limitations.** The “General Provisions” of the Caltrans Standard Specifications, i.e., sections 1 through 9, do not apply to these Contract Documents with the exception of any specific provisions, if any, which are expressly stated to apply to these Contract Documents.

(B) **Conflicts or Inconsistencies.** If there is a conflict or inconsistency between any provision in the Caltrans Standard Specifications or Special Provisions and a provision of these Contract Documents, as determined by City, the provision in the Contract Documents will govern.

(C) **Meanings.** Terms used in the Caltrans Standard Specifications or Special Provisions are to be interpreted as follows:

(1) Any reference to the “Engineer” is deemed to mean the City Engineer.

(2) Any reference to the “Special Provisions” is deemed to mean the Special Conditions, unless the Caltrans Special Provisions are expressly included in the Contract Documents listed in Section 2 of the Contract.

(3) Any reference to the “Department” or “State” is deemed to mean City.

3.4 For Reference Only. Contractor is responsible for the careful review of any document, study, or report provided by City or appended to the Contract Documents solely for informational purposes and identified as “For Reference Only.” Nothing in any document,

study, or report so appended and identified is intended to supplement, alter, or void any provision of the Contract Documents. Contractor is advised that City or its representatives may be guided by information or recommendations included in such reference documents, particularly when making determinations as to the acceptability of proposed materials, methods, or changes in the Work. Any record drawings or similar final or accepted drawings or maps that are not part of the Contract Documents are deemed to be For Reference Only. The provisions of the Contract Documents are not modified by any perceived or actual conflict with provisions in any document that is provided For Reference Only.

- 3.5 Current Versions.** Unless otherwise specified by City, any reference to standard specifications, technical specifications, or any City or state codes or regulations means the latest specification, code, or regulation in effect on the date that bids were due.
- 3.6 Conformed Copies.** If City prepares a conformed set of the Contract Documents following award of the Contract, it will provide Contractor with one copy of the electronic file in PDF format. It is Contractor's responsibility to ensure that all Subcontractors, including fabricators, are provided with the conformed set of the Contract Documents at Contractor's sole expense.
- 3.7 Ownership.** No portion of the Contract Documents may be used for any purpose other than construction of the Project, without prior written consent from City. Contractor is deemed to have conveyed the copyright in any designs, drawings, specifications, Shop Drawings, or other documents (in paper or electronic form) developed by Contractor for the Project, and City will retain all rights to such works, including the right to possession.

Article 4 - Bonds, Indemnity, and Insurance

- 4.1 Payment and Performance Bonds.** Within ten days following issuance of the Notice of Potential Award, Contractor is required to provide a payment bond and a performance bond, each in the penal sum of not less than 100% of the Contract Price, and each executed by Contractor and its surety using the bond forms included with the Contract Documents.
- (A) **Surety.** Each bond must be issued and executed by a surety admitted in California. If an issuing surety cancels the bond or becomes insolvent, within seven days following written notice from City, Contractor must substitute a surety acceptable to City. If Contractor fails to substitute an acceptable surety within the specified time, City may, at its sole discretion, withhold payment from Contractor until the surety is replaced to City's satisfaction, or terminate the Contract for default.
- (B) **Supplemental Bonds for Increase in Contract Price.** If the Contract Price increases during construction by five percent or more over the original Contract Price, Contractor must provide supplemental or replacement bonds within ten days of written notice from City pursuant to this Section, covering 100% of the increased Contract Price and using the bond forms included with the Contract Documents.
- 4.2 Indemnity.** To the fullest extent permitted by law, Contractor must indemnify, defend, and hold harmless City, its Council, officers, officials, employees, agents, volunteers, and consultants (individually, an "Indemnitee," and collectively the "Indemnitees") from and against any and all liability, loss, damage, claims, causes of action, demands, charges, fines, costs, and expenses (including, without limitation, attorney fees, expert witness fees, paralegal fees, and fees and costs of litigation or arbitration) (collectively, "Liability") of every nature arising out of or in connection with the acts or omissions of Contractor, its

employees, Subcontractors, representatives, or agents, in bidding or performing the Work or in failing to comply with any obligation of Contractor under the Contract, except such Liability caused by the active negligence, sole negligence, or willful misconduct of an Indemnitee. This indemnity requirement applies to any Liability arising from alleged defects in the content or manner of submission of Contractor's bid for the Contract. Contractor's failure or refusal to timely accept a tender of defense pursuant to this Contract will be deemed a material breach of the Contract. City will timely notify Contractor upon receipt of any third-party claim relating to the Contract, as required by Public Contract Code § 9201. Contractor waives any right to express or implied indemnity against any Indemnitee. Contractor's indemnity obligations under this Contract will survive the expiration or any early termination of the Contract.

4.3 Insurance. No later than ten days following issuance of the Notice of Potential Award, Contractor must procure and provide proof of the insurance coverage required by this Section in the form of certificates and endorsements acceptable to City. The required insurance must cover the activities of Contractor and its Subcontractors relating to or arising from the performance of the Work, and must remain in full force and effect at all times during the period covered by the Contract, through the date of City's acceptance of the Project. All required insurance must be issued by a company licensed to do business in the State of California, and each such insurer must have an A.M. Best's financial strength rating of "A" or better and a financial size rating of "VIII" or better. If Contractor fails to provide any of the required coverage in full compliance with the requirements of the Contract Documents, City may, at its sole discretion, purchase such coverage at Contractor's expense and deduct the cost from payments due to Contractor, or terminate the Contract for default. The procurement of the required insurance will not be construed to limit Contractor's liability under this Contract or to fulfill Contractor's indemnification obligations under this Contract.

(A) **Policies and Limits.** The following insurance policies and limits are required for this Contract, unless otherwise specified in the Special Conditions:

(1) *Commercial General Liability ("CGL") Insurance:* The CGL insurance policy must be issued on an occurrence basis, written on a comprehensive general liability form, and must include coverage for liability arising from Contractor's or its Subcontractor's acts or omissions in the performance of the Work, including contractor's protective coverage, contractual liability, products and completed operations, and broad form property damage, with limits of at least \$2,000,000 per occurrence and at least \$4,000,000 general aggregate. The CGL insurance coverage may be arranged under a single policy for the full limits required or by a combination of underlying policies with the balance provided by excess or umbrella policies, provided each such policy complies with the requirements set forth in this Section, including required endorsements.

(2) *Automobile Liability Insurance:* The automobile liability insurance policy must provide coverage of at least \$2,000,000 combined single-limit per accident for bodily injury, death, or property damage, including hired and non-owned auto liability.

(3) *Workers' Compensation Insurance and Employer's Liability:* The workers' compensation and employer's liability insurance policy must comply with the requirements of the California Labor Code, providing coverage of at least \$1,000,000 or as otherwise required by the statute. If Contractor is self-insured, Contractor must provide its Certificate of Permission to Self-Insure, duly authorized by the DIR.

(4) *Pollution Liability Insurance*: The pollution liability insurance policy must be issued on an occurrence basis, providing coverage of at least \$2,000,000 for all loss arising out of claims for bodily injury, death, property damage, or environmental damage caused by pollution conditions resulting from the Work.

(5) *Builder's Risk Insurance*: The builder's risk insurance policy must be issued on an occurrence basis, for all-risk or "all perils" coverage on a 100% completed value basis on the insurable portion of the Project for the benefit of City.

(B) **Notice**. Each certificate of insurance must state that the coverage afforded by the policy or policies will not be reduced, cancelled or allowed to expire without at least 30 days advance written notice to City, unless due to non-payment of premiums, in which case ten days advance written notice must be made to City.

(C) **Waiver of Subrogation**. Each required policy must include an endorsement providing that the carrier will waive any right of subrogation it may have against City.

(D) **Required Endorsements**. The CGL policy, automobile liability policy, pollution liability policy, and builder's risk policy must include the following specific endorsements:

(1) The City, including its Council, officials, officers, employees, agents, volunteers and consultants (collectively, "Additional Insured") must be named as an additional insured for all liability arising out of the operations by or on behalf of the named insured, and the policy must protect the Additional Insured against any and all liability for personal injury, death or property damage or destruction arising directly or indirectly in the performance of the Contract. The additional insured endorsement must be provided using ISO form CG 20 10 11 85 or equivalent form(s) approved by the City.

(2) The inclusion of more than one insured will not operate to impair the rights of one insured against another, and the coverages afforded will apply as though separate policies have been issued to each insured.

(3) The insurance provided by Contractor is primary and no insurance held or owned by any Additional Insured may be called upon to contribute to a loss.

(4) This policy does not exclude explosion, collapse, underground excavation hazard, or removal of lateral support.

(E) **Contractor's Responsibilities**. This Section 4.3 establishes the minimum requirements for Contractor's insurance coverage in relation to this Project, but is not intended to limit Contractor's ability to procure additional or greater coverage. Contractor is responsible for its own risk assessment and needs and is encouraged to consult its insurance provider to determine what coverage it may wish to carry beyond the minimum requirements of this Section. Contractor is solely responsible for the cost of its insurance coverage, including premium payments, deductibles, or self-insured retentions, and no Additional Insured will be responsible or liable for any of the cost of Contractor's insurance coverage.

(F) **Deductibles and Self-Insured Retentions**. Any deductibles or self-insured retentions that apply to the required insurance (collectively, "deductibles") in excess of \$100,000 are subject to approval by the City's Risk Manager, acting in his or her sole discretion, and must be declared by Contractor when it submits its certificates of insurance and endorsements pursuant to this Section 4.3. If the City's Risk Manager determines that the deductibles are unacceptably high, at City's option, Contractor must either reduce or eliminate the deductibles as they apply to City and all required Additional

Insured; or must provide a financial guarantee, to City's satisfaction, guaranteeing payment of losses and related investigation, claim administration, and legal expenses.

(G) **Subcontractors.** Contractor must ensure that each Subcontractor is required to maintain the same insurance coverage required under this Section 4.3, with respect to its performance of Work on the Project, including those requirements related to the Additional Insureds and waiver of subrogation, but excluding pollution liability or builder's risk insurance unless otherwise specified in the Special Conditions. A Subcontractor may be eligible for reduced insurance coverage or limits, but only to the extent approved in writing in advance by the City's Risk Manager. Contractor must confirm that each Subcontractor has complied with these insurance requirements before the Subcontractor is permitted to begin Work on the Project. Upon request by the City, Contractor must provide certificates and endorsements submitted by each Subcontractor to prove compliance with this requirement. The insurance requirements for Subcontractors do not replace or limit the Contractor's insurance obligations.

Article 5 - Contract Time

5.1 Time is of the Essence. Time is of the essence in Contractor's performance and completion of the Work, and Contractor must diligently prosecute the Work and complete it within the Contract Time.

(A) **General.** Contractor must commence the Work on the date indicated in the Notice to Proceed and must fully complete the Work in strict compliance with all requirements of the Contract Documents and within the Contract Time. Contractor may not begin performing the Work before the date specified in the Notice to Proceed.

(B) **Authorization.** Contractor is not entitled to compensation or credit for any Work performed before the date specified in the Notice to Proceed, with the exception of any schedules, submittals, or other requirements, if any, that must be provided or performed before issuance of the Notice to Proceed.

(C) **Rate of Progress.** Contractor and its Subcontractors must, at all times, provide workers, materials, and equipment sufficient to maintain the rate of progress necessary to ensure full completion of the Work within the Contract Time. If City determines that Contractor is failing to prosecute the Work at a sufficient rate of progress, City may, in its sole discretion, direct Contractor to provide additional workers, materials, or equipment, or to work additional hours or days without additional cost to City, in order to achieve a rate of progress satisfactory to City. If Contractor fails to comply with City's directive in this regard, City may, at Contractor's expense, separately contract for additional workers, materials, or equipment or use City's own forces to achieve the necessary rate of progress. Alternatively, City may terminate the Contract based on Contractor's default.

5.2 Schedule Requirements. Contractor must prepare all schedules using standard, commercial scheduling software acceptable to the Engineer, and must provide the schedules in electronic and paper form as requested by the Engineer. In addition to the general scheduling requirements set forth below, Contractor must also comply with any scheduling requirements included in the Special Conditions or in the Technical Specifications.

(A) **Baseline (As-Planned) Schedule.** Within ten calendar days following City's issuance of the Notice to Proceed (or as otherwise specified in the Notice to Proceed), Contractor must submit to City for review and acceptance a baseline (as-planned) schedule using critical path methodology showing in detail how Contractor plans to perform and fully complete the Work within the Contract Time, including labor,

equipment, materials, and fabricated items. The baseline schedule must show the order of the major items of Work and the dates of start and completion of each item, including when the materials and equipment will be procured. The schedule must also include the work of all trades, reflecting anticipated labor or crew hours and equipment loading for the construction activities, and must be sufficiently comprehensive and detailed to enable progress to be monitored on a day-by-day basis. For each activity, the baseline schedule must be dated, provided in the format specified in the Contract Documents or as required by City, and must include, at a minimum, a description of the activity, the start and completion dates of the activity, and the duration of the activity.

(1) *Specialized Materials Ordering.* Within five calendar days following issuance of the Notice to Proceed, Contractor must order any specialized material or equipment for the Work that is not readily available from material suppliers. Contractor must also retain documentation of the purchase order date(s).

(B) **City's Review of Schedules.** City will review and may note exceptions to the baseline schedule, and to the progress schedules submitted as required below, to assure completion of the Work within the Contract Time. Contractor is solely responsible for resolving any exceptions noted in a schedule and, within seven days, must correct the schedule to address the exceptions. City's review or acceptance of Contractor's schedules will not operate to waive or limit Contractor's duty to complete the Project within the Contract Time, nor to waive or limit City's right to assess liquidated damages for Contractor's unexcused failure to do so.

(C) **Progress Schedules.** After City accepts the final baseline schedule with no exceptions, Contractor must submit an updated progress schedule and three-week look-ahead schedule, in the format specified by City, for review and acceptance with each application for a progress payment, or when otherwise specified by City, until completion of the Work. The updated progress schedule must: show how the actual progress of the Work as constructed to date compares to the baseline schedule; reflect any proposed changes in the construction schedule or method of operations, including to achieve Project milestones within the Contract Time; and identify any actual or potential impacts to the critical path. Contractor must also submit periodic reports to City of any changes in the projected material or equipment delivery dates for the Project.

(1) *Float.* The progress schedule must show early and late completion dates for each task. The number of days between those dates will be designated as the "float." Any float belongs to the Project and may be allocated by the Engineer to best serve timely completion of the Project.

(2) *Failure to Submit Schedule.* Reliable, up-to-date schedules are essential to efficient and cost-effective administration of the Project and timely completion. If Contractor fails to submit a schedule within the time periods specified in this Section, or submits a schedule to which City has noted exceptions that are not corrected, City may withhold up to five percent from payment(s) otherwise due to Contractor until the exceptions are resolved, the schedule is corrected and resubmitted, and City has accepted the schedule. In addition, Contractor's failure to comply with the schedule requirements in this Section 5.2 will be deemed a material default and a waiver of any claims for Excusable Delay or loss of productivity arising during any period when Contractor is out of compliance, subject only to the limits of Public Contract Code § 7102.

(D) **Recovery Schedule.** If City determines that the Work is more than one week behind schedule, within seven days following written notice of such determination, Contractor must submit a recovery schedule, showing how Contractor intends to perform and complete the Work within the Contract Time, based on actual progress to date.

(E) **Effect of Acceptance.** Contractor and its Subcontractors must perform the Work in accordance with the most current City-accepted schedule unless otherwise directed by City. City's acceptance of a schedule does not operate to extend the time for completion of the Work or any component of the Work, and will not affect City's right to assess liquidated damages for Contractor's unexcused delay in completing the Work within the Contract Time.

(F) **Posting.** Contractor must at all times prominently post a copy of the most current City-accepted progress or recovery schedule in its on-site office.

(G) **Reservation of Rights.** City reserves the right to direct the sequence in which the Work must be performed or to make changes in the sequence of the Work in order to facilitate the performance of work by City or others, or to facilitate City's use of its property. The Contract Time or Contract Price may be adjusted to the extent such changes in sequence actually increase or decrease Contractor's time or cost to perform the Work.

(H) **Authorized Working Days and Times.** Contractor is limited to working Monday through Friday, excluding holidays, during City's normal business hours, except as provided in the Special Conditions or as authorized in writing by City. City reserves the right to charge Contractor for additional costs incurred by City due to Work performed on days or during hours not expressly authorized in the Contract Documents, including reimbursement of costs incurred for inspection, testing, and construction management services.

5.3 Delay and Extensions of Contract Time.

(A) **Notice of Delay.** If Contractor becomes aware of any actual or potential delay affecting the critical path, Contractor must promptly notify the Engineer in writing, regardless of the nature or cause of the delay, so that City has a reasonable opportunity to mitigate or avoid the delay.

(B) **Excusable Delay.** The Contract Time may be extended if Contractor encounters "Excusable Delay," which is an unavoidable delay in completing the Work within the Contract Time due to causes completely beyond Contractor's control, and which Contractor could not have avoided or mitigated through reasonable care, planning, foresight, or diligence, provided that Contractor is otherwise fully performing its obligations under the Contract Documents. Grounds for Excusable Delay may include fire, natural disasters including earthquake or unusually severe weather, acts of terror or vandalism, epidemic, unforeseeable adverse government actions, unforeseeable actions of third parties, encountering unforeseeable hazardous materials, unforeseeable site conditions, or suspension for convenience under Article 13. The Contract Time will not be extended based on circumstances which will not unavoidably delay completing the Work within the Contract Time based on critical path analysis.

(C) **Weather Delays.** A "Weather Delay Day" is a Working Day during which Contractor and its forces, including Subcontractors, are unable to perform more than 40% of the critical path Work scheduled for that day due to adverse weather conditions which impair the ability to safely or effectively perform the scheduled critical path Work that day. Adverse weather conditions may include rain, saturated soil, and Project site clean-up required due to adverse weather. Determination of what constitutes critical path Work scheduled for that day will be based on the most current, City-approved schedule. Contractor will be entitled to a non-compensable extension of the Contract Time for each Weather Delay Day in excess of the normal Weather Delay Days within a given month as

determined by reliable records, including monthly rainfall averages, for the preceding ten years (or as otherwise specified in the Special Conditions or Specifications).

(1) Contractor must fully comply with the applicable procedures in Articles 5 and 6 of the General Conditions regarding requests to modify the Contract Time.

(2) Contractor will not be entitled to an extension of time for a Weather Delay Day to the extent Contractor is responsible for concurrent delay on that day.

(3) Contractor must take reasonable steps to mitigate the consequences of Weather Delay Days, including prudent workforce management and protecting the Work, Project Site, materials, and equipment.

(D) **Non-Excusable Delay.** Delay which Contractor could have avoided or mitigated through reasonable care, planning, foresight, or diligence is "Non-Excusable Delay." Contractor is not entitled to an extension of Contract Time or any compensation for Non-Excusable Delay, or for Excusable Delay that is concurrent with Non-Excusable Delay. Non-Excusable Delay includes delay caused by:

(1) weather conditions which are normal for the location of the Project, as determined by reliable records, including monthly rainfall averages, for the preceding ten years;

(2) Contractor's failure to order equipment and materials sufficiently in advance of the time needed for completion of the Work within the Contract Time;

(3) Contractor's failure to provide adequate notification to utility companies or agencies for connections or services necessary for completion of the Work within the Contract Time;

(4) foreseeable conditions which Contractor could have ascertained from reasonably diligent inspection of the Project site or review of the Contract Documents or other information provided or available to Contractor;

(5) Contractor's failure, refusal, or financial inability to perform the Work within the Contract Time, including insufficient funds to pay its Subcontractors or suppliers;

(6) performance or non-performance by Contractor's Subcontractors or suppliers;

(7) the time required to respond to excessive RFIs (see Section 2.5(G));

(8) delayed submission of required submittals, or the time required for correction and resubmission of defective submittals;

(9) time required for repair of, re-testing, or re-inspection of defective Work;

(10) enforcement of Laws by City, or outside agencies with jurisdiction over the Work; or

(11) City's exercise or enforcement of any of its rights or Contractor's duties pursuant to the Contract Documents, including correction of defective Work, extra inspections or testing due to non-compliance with Contract requirements, safety compliance, environmental compliance, or rejection and return of defective or deficient submittals.

(E) **Compensable Delay.** Pursuant to Public Contract Code § 7102, in addition to entitlement to an extension of Contract Time, Contractor is entitled to compensation for costs incurred due to delay caused solely by City, when that delay is unreasonable under the circumstances involved and not within the contemplation of the parties (“Compensable Delay”). Contractor is not entitled to an extension of Contract Time or recovery of costs for Compensable Delay that is concurrent with Non-Excusable Delay. Delay due to Weather Delay Days in excess of normal for a given month, as set forth in Section 5.3(C), is not Compensable Delay, and will only entitle Contractor to an extension of time commensurate with the time lost due to such delay.

(F) **Recoverable Costs.** Contractor is not entitled to compensation for Excusable Delay unless it is Compensable Delay, as defined above. Contractor is entitled to recover only the actual, direct, reasonable, and substantiated costs (“Recoverable Costs”) for each working day that the Compensable Delay prevents Contractor from proceeding with more than 50% of the critical path Work scheduled for that day, based on the most recent progress schedule accepted by City. Recoverable Costs will not include home office overhead or lost profit.

(G) **Request for Extension of Contract Time or Recoverable Costs.** A request for an extension of Contract Time or any associated Recoverable Costs must be submitted in writing to City within 14 calendar days of the date the delay is first encountered, even if the duration of the delay is not yet known at that time, or any entitlement to the Contract Time extension or to the Recoverable Costs will be deemed waived. In addition to complying with the requirements of this Article 5, the request must be submitted in compliance with the Change Order request procedures in Article 6 below. Strict compliance with these requirements is necessary to ensure that any delay or consequences of delay may be mitigated as soon as possible, and to facilitate cost-efficient administration of the Project and timely performance of the Work. Any request for an extension of Contract Time or Recoverable Costs that does not strictly comply with all of the requirements of Article 5 and Article 6 will be deemed waived.

(1) **Required Contents.** The request must include a detailed description of the cause(s) of the delay and must also describe the measures that Contractor has taken to mitigate the delay and/or its effects, including efforts to mitigate the cost impact of the delay, such as by workforce management or by a change in sequencing. If the delay is still ongoing at the time the request is submitted, the request should also include Contractor’s plan for continued mitigation of the delay or its effects.

(2) **Delay Days and Costs.** The request must specify the number of days of Excusable Delay claimed or provide a realistic estimate if the duration of the delay is not yet known. If Contractor believes it is entitled to Recoverable Costs for Compensable Delay, the request must specify the amount and basis for the Recoverable Costs that are claimed or provide a realistic estimate if the amount is not yet known. Any estimate of delay duration or cost must be updated in writing and submitted with all required supporting documentation as soon as the actual time and cost is known. The maximum extension of Contract Time will be the number of days, if any, by which an Excusable Delay or a Compensable Delay exceeds any concurrent Non-Excusable Delay. Contractor is entitled to an extension of Contract Time, or compensation for Recoverable Costs, only if, and only to the extent that, such delay will unavoidably delay Final Completion.

(3) **Supporting Documentation.** The request must also include any and all supporting documentation necessary to evidence the delay and its actual impacts, including scheduling and cost impacts with a time impact analysis using

critical path methodology and demonstrating the unavoidable delay to Final Completion. The time impact analysis must be submitted in a form or format acceptable to City.

(4) *Burden of Proof.* Contractor has the burden of proving that: the delay was an Excusable Delay or Compensable Delay, as defined above; Contractor has fully complied with its scheduling obligations in Section 5.2, Schedule Requirements; Contractor has made reasonable efforts to mitigate the delay and its schedule and cost impacts; the delay will unavoidably result in delaying Final Completion; and any Recoverable Costs claimed by Contractor were actually incurred and were reasonable under the circumstances.

(5) *Legal Compliance.* Nothing in this Section 5.3 is intended to require the waiver, alteration, or limitation of the applicability of Public Contract Code § 7102.

(6) *No Waiver.* Any grant of an extension of Contract Time, or compensation for Recoverable Costs due to Compensable Delay, will not operate as a waiver of City's right to assess liquidated damages for Non-Excusable Delay.

(7) *Dispute Resolution.* In the event of a dispute over entitlement to an extension of Contract Time or compensation for Recoverable Costs, Contractor may not stop Work pending resolution of the dispute, but must continue to comply with its duty to diligently prosecute the performance and timely completion of the Work. Contractor's sole recourse for an unresolved dispute based on City's rejection of a Change Order request for an extension of Contract Time or compensation for Recoverable Costs is to comply with the dispute resolution provisions set forth in Article 12 below.

5.4 Liquidated Damages. It is expressly understood that if Final Completion is not achieved within the Contract Time, City will suffer damages from the delay that are difficult to determine and accurately specify. Pursuant to Public Contract Code § 7203, if Contractor fails to achieve Final Completion within the Contract Time due to Contractor's Non-Excusable Delay, City will charge Contractor in the amount specified in the Contract for each calendar day that Final Completion is delayed beyond the Contract Time, as liquidated damages and not as a penalty. Any waiver of accrued liquidated damages, in whole or in part, is subject to approval of the City Council or its authorized delegee.

(A) **Liquidated Damages.** Liquidated damages will not be assessed for any Excusable Delay or Compensable Delay, as set forth above.

(B) **Milestones.** Liquidated damages may also be separately assessed for failure to meet milestones specified elsewhere in the Contract Documents.

(C) **Setoff.** City is entitled to deduct the amount of liquidated damages assessed against any payments otherwise due to Contractor, including progress payments, Final Payment, or unreleased retention. If there are insufficient Contract funds remaining to cover the full amount of liquidated damages assessed, City is entitled to recover the balance from Contractor or its performance bond surety.

(D) **Occupancy or Use.** Occupancy or use of the Project in whole or in part prior to Final Completion does not constitute City's acceptance of the Project and will not operate as a waiver of City's right to assess liquidated damages for Contractor's Non-Excusable Delay in achieving Final Completion.

(E) **Other Remedies.** City's right to liquidated damages under this Section applies only to damages arising from Contractor's Non-Excusable Delay or failure to complete

the Work within the Contract Time. City retains its right to pursue all other remedies under the Contract for other types of damage, including damage to property or persons, costs or diminution in value from defective materials or workmanship, costs to repair or complete the Work, or other liability caused by Contractor.

Article 6 - Contract Modification

6.1 Contract Modification. Subject to the limited exception set forth in subsection (D) below, any change in the Work or the Contract Documents, including the Contract Price or Contract Time, will not be a valid and binding change to the Contract unless it is formalized in a Change Order, including a “no-cost” Change Order or a unilateral Change Order. Changes in the Work pursuant to this Article 6 will not operate to release, limit, or abridge Contractor’s warranty obligations pursuant to Article 11 or any obligations of Contractor’s bond sureties.

(A) **City-Directed Changes.** City may direct changes in the scope or sequence of Work or the requirements of the Contract Documents, without invalidating the Contract. Such changes may include Extra Work as set forth in subsection (C) below, or deletion or modification of portions of the Work. Contractor must promptly comply with City-directed changes in the Work in accordance with the original Contract Documents, even if Contractor and City have not yet reached agreement as to adjustments to the Contract Price or Contract Time for the change in the Work or for the Extra Work. Contractor is not entitled to extra compensation for cost savings resulting from “value engineering” pursuant to Public Contract Code § 7101, except to the extent authorized in advance by City in writing, and subject to any applicable procedural requirements for submitting a proposal for value engineering cost savings.

(B) **Disputes.** In the event of a dispute over entitlement to or the amount of a change in Contract Time or a change in Contract Price related to a City-directed change in the Work, Contractor must perform the Work as directed and may not delay its Work or cease Work pending resolution of the dispute, but must continue to comply with its duty to diligently prosecute the performance and timely completion of the Work, including the Work in dispute. Likewise, in the event that City and Contractor dispute whether a portion or portions of the Work are already required by the Contract Documents or constitute Extra Work, or otherwise dispute the interpretation of any portion(s) of the Contract Documents, Contractor must perform the Work as directed and may not delay its Work or cease Work pending resolution of the dispute, but must continue to comply with its duty to diligently prosecute the performance and timely completion of the Work, including the Work in dispute, as directed by City. If Contractor refuses to perform the Work in dispute, City may, acting in its sole discretion, elect to delete the Work from the Contract and reduce the Contract Price accordingly, and self-perform the Work or direct that the Work be performed by others. Alternatively, City may elect to terminate the Contract for convenience or for cause. Contractor’s sole recourse for an unresolved dispute related to changes in the Work or performance of any Extra Work is to comply with the dispute resolution provisions set forth in Article 12, below.

(C) **Extra Work.** City may direct Contractor to perform Extra Work related to the Project. Contractor must promptly perform any Extra Work as directed or authorized by City in accordance with the original Contract Documents, even if Contractor and City have not yet reached agreement on adjustments to the Contract Price or Contract Time for such Extra Work. If Contractor believes it is necessary to perform Extra Work due to changed conditions, Contractor must promptly notify the Engineer in writing, specifically identifying the Extra Work and the reason(s) the Contractor believes it is Extra Work. This notification requirement does not constitute a Change Order request pursuant to Section 6.2, below. Contractor must maintain detailed daily records that itemize the cost of each

element of Extra Work, and sufficiently distinguish the direct cost of the Extra Work from the cost of other Work performed. For each day that Contractor performs Extra Work, or Work that Contractor contends is Extra Work, Contractor must submit no later than the following Working Day, a daily report of the Extra Work performed that day and the related costs, together with copies of certified payroll, invoices, and other documentation substantiating the costs ("Extra Work Report"). The Engineer will make any adjustments to Contractor's Extra Work Report(s) based on the Engineer's records of the Work. When an Extra Work Report(s) is agreed on and signed by both City and Contractor, the Extra Work Report(s) will become the basis for payment under a duly authorized and signed Change Order. Failure to submit the required documentation by close of business on the next Working Day is deemed a full and complete waiver for any change in the Contract Price or Contract Time for any Extra Work performed that day.

(D) **Minor Changes and RFIs.** Minor field changes, including RFI replies from City, that do not affect the Contract Price or Contract Time and that are approved by the Engineer acting within his or her scope of authority, do not require a Change Order. By executing an RFI reply from City, Contractor agrees that it will perform the Work as clarified therein, with no change to the Contract Price or Contract Time.

(E) **Remedy for Non-Compliance.** Contractor's failure to promptly comply with a City-directed change is deemed a material breach of the Contract, and in addition to all other remedies available to it, City may, at its sole discretion, hire another contractor or use its own forces to complete the disputed Work at Contractor's sole expense, and may deduct the cost from the Contract Price.

6.2 Contractor Change Order Requests. Contractor must submit a request or proposal for a change in the Work, compensation for Extra Work, or a change in the Contract Price or Contract Time as a written Change Order request or proposal.

(A) **Time for Submission.** Any request for a change in the Contract Price or the Contract Time must be submitted in writing to the Engineer within 14 calendar days of the date that Contractor first encounters the circumstances, information or conditions giving rise to the Change Order request, even if the total amount of the requested change in the Contract Price or impact on the Contract Time is not yet known at that time. If City requests that Contractor propose the terms of a Change Order, unless otherwise specified in City's request, Contractor must provide the Engineer with a written proposal for the change in the Contract Price or Contract Time within five working days of receiving City's request, in a form satisfactory to the Engineer.

(B) **Required Contents.** Any Change Order request or proposal submitted by Contractor must include a complete breakdown of actual or estimated costs and credits, and must itemize labor, materials, equipment, taxes, insurance, subcontract amounts, and, if applicable, Extra Work Reports. Any estimated cost must be updated in writing as soon as the actual amount is known.

(C) **Required Documentation.** All claimed costs must be fully documented, and any related request for an extension of time or delay-related costs must be included at that time and in compliance with the requirements of Article 5 of the General Conditions. Upon request, Contractor must permit City to inspect its original and unaltered bidding records, subcontract agreements, subcontract change orders, purchase orders, invoices, or receipts associated with the claimed costs.

(D) **Required Form.** Contractor must use City's form(s) for submitting all Change Order requests or proposals, unless otherwise specified by City.

(E) **Certification.** All Change Order requests must be signed by Contractor and must include the following certification:

“The undersigned Contractor certifies under penalty of perjury that its statements and representations in this Change Order request are true and correct. Contractor warrants that this Change Order request is comprehensive and complete as to the Work or changes referenced herein, and agrees that any known or foreseeable costs, expenses, or time extension requests not included herein, are deemed waived.”

6.3 Adjustments to Contract Price. The amount of any increase or decrease in the Contract Price will be determined based on one of the following methods listed below, in the order listed with unit pricing taking precedence over the other methods. Markup applies only to City-authorized time and material Work, and does not apply to any other payments to Contractor. For Work items or components that are deleted in their entirety, Contractor will only be entitled to compensation for those direct, actual, and documented costs (including restocking fees), reasonably incurred before Contractor was notified of the City’s intent to delete the Work, with no markup for overhead, profit, or other indirect costs.

(A) **Unit Pricing.** Amounts previously provided by Contractor in the form of unit prices, either in a bid schedule or in a post-award schedule of values pursuant to Section 8.1, Schedule of Values, will apply to determine the price for the affected Work, to the extent applicable unit prices have been provided for that type of Work. No additional markup for overhead, profit, or other indirect costs will be added to the calculation.

(B) **Lump Sum.** A mutually agreed upon, all-inclusive lump sum price for the affected Work with no additional markup for overhead, profit, or other indirect costs.

(C) **Time and Materials.** On a time and materials basis, if and only to the extent compensation on a time and materials basis is expressly authorized by City in advance of Contractor’s performance of the Work and subject to any not-to-exceed limit. Time and materials compensation for increased costs or Extra Work (but not decreased costs or deleted Work) will include allowed markup for overhead, profit, and other indirect costs, calculated as the total of the following sums, the cumulative total of which may not exceed the maximum markup rate of 15%:

(1) All direct labor costs provided by the Contractor, excluding superintendence, project management, or administrative costs, plus 15% markup;

(2) All direct material costs provided by the Contractor, including sales tax, plus 15% markup;

(3) All direct plant and equipment rental costs provided by the Contractor, plus 15% markup;

(4) All direct additional subcontract costs plus 10% markup for Work performed by Subcontractors; and

(5) Increased bond or insurance premium costs computed at 1.5% of the total of the previous four sums.

6.4 Unilateral Change Order. If the parties dispute the terms of a proposed Change Order, including disputes over the amount of compensation or extension of time that Contractor has requested, the value of deleted or changed Work, what constitutes Extra Work, or quantities used, City may elect to issue a unilateral Change Order, directing performance

of the Work, and authorizing a change in the Contract Price or Contract Time for the adjustment to compensation or time that the City believes is merited. Contractor's sole recourse to dispute the terms of a unilateral Change Order is to submit a timely Claim pursuant to Article 12, below.

- 6.5 Non-Compliance Deemed Waiver.** Contractor waives its entitlement to any increase in the Contract Price or Contract Time if Contractor fails to fully comply with the provisions of this Article. Contractor will not be paid for unauthorized Extra Work.

Article 7 - General Construction Provisions

7.1 Permits, Fees, Business License, and Taxes.

(A) **Permits, Fees, and City Business License.** Contractor must obtain and pay for all permits, fees, and licenses required to perform the Work, including a City business license. Contractor must cooperate with and provide notifications to all government agencies with jurisdiction over the Project, as may be required. Contractor must provide City with copies of all records of permits and permit applications, payment of required fees, and any licenses required for the Work.

(B) **Taxes.** Contractor must pay for all taxes on labor, material, and equipment, except Federal Excise Tax to the extent that City is exempt from Federal Excise Tax.

- 7.2 Temporary Facilities.** Contractor must provide, at Contractor's sole expense, any and all temporary facilities for the Project, including an onsite staging area for materials and equipment, a field office, sanitary facilities, utilities, storage, scaffolds, barricades, walkways, and any other temporary structure required to safely perform the Work along with any incidental utility services. The location of all temporary facilities must be approved by the City prior to installation. Temporary facilities must be safe and adequate for the intended use and installed and maintained in accordance with Laws and the Contract Documents. Contractor must fence and screen the Project site and, if applicable, any separate Worksites, including the staging area, and its operation must minimize inconvenience to neighboring properties. Additional provisions pertaining to temporary facilities may be included in the Specifications or Special Conditions.

(A) **Utilities.** Contractor must install and maintain the power, water, sewer, and all other utilities required for the Project site, including the piping, wiring, internet and wifi connections, and any related equipment necessary to maintain the temporary facilities.

(B) **Removal and Repair.** Contractor must promptly remove all such temporary facilities when they are no longer needed or upon completion of the Work, whichever comes first. Contractor must promptly repair any damage to City's property or to other property caused by the installation, use, or removal of the temporary facilities, and must promptly restore the property to its original or intended condition.

- 7.3 Noninterference and Site Management.** Contractor must avoid interfering with City's use of its property at or adjacent to the Project site, including use of roadways, entrances, parking areas, walkways, and structures. Contractor must also minimize disruption of access to private property in the Project vicinity. Contractor must coordinate with affected property owners, tenants, and businesses, and maintain some vehicle and pedestrian access to their residences or properties at all times. Temporary access ramps, fencing or other measures must be provided as needed. Before blocking access to a private driveway or parking lot, Contractor must provide effective notice to the affected parties at least 48 hours in advance of the pending closure and allow them to remove vehicles.

Private driveways, residences and parking lots must have access to a roadway during non-Work hours.

(A) **Offsite Acquisition.** Unless otherwise provided by City, Contractor must acquire, use, and dispose of, at its sole expense, any Worksites, licenses, easements, and temporary facilities necessary to access and perform the Work.

(B) **Offsite Staging Area and Field Office.** If additional space beyond the Project site is needed, such as for the staging area or the field office, Contractor may need to make arrangements with the nearby property owner(s) to secure the space. Before using or occupying any property owned by a third party, Contractor must provide City with a copy of the necessary license agreement, easement, or other written authorization from the property owner, together with a written release from the property owner holding City harmless from any related liability, in a form acceptable to the City Attorney.

(C) **Traffic Management.** Contractor must provide traffic management and traffic controls as specified in the Contract Documents, as required by Laws, and as otherwise required to ensure public and worker safety, and to avoid interference with public or private operations or the normal flow of vehicular, bicycle, or pedestrian traffic.

7.4 Signs. No signs may be displayed on or about City's property, except signage which is required by Laws or by the Contract Documents, without City's prior written approval as to size, design, and location. Contractor must furnish and install all signs at Contractor's sole expense, including signs required by Laws or the Contract Documents

7.5 Project Site and Nearby Property Protections.

(A) **General.** Contractor is responsible at all times, on a 24-hour basis and at its sole cost, for protecting the Work, the Project site, and the materials and equipment to be incorporated into the Work, until the City has accepted the Project, excluding any exceptions to acceptance, if any. Except as specifically authorized by City, Contractor must confine its operations to the area of the Project site indicated in the Plans and Specifications. Contractor is liable for any damage caused by Contractor or its Subcontractors to the Work, City's property, the property of adjacent or nearby property owners and the work or personal property of other contractors working for City, including damage related to Contractor's failure to adequately secure the Work or any Worksite.

(1) Subject to City's approval, Contractor will provide and install safeguards to protect the Work; any Worksite, including the Project site; City's real or personal property and the real or personal property of adjacent or nearby property owners, including plant and tree protections.

(2) Cupertino Sanitary District and the City of Sunnyvale own and operate wastewater systems within City and they may not be interrupted. If the Work disrupts existing sewer facilities, Contractor must immediately notify City and establish a plan, subject to City's approval, to convey the sewage in closed conduits back into the sanitary sewer system. Sewage must not be permitted to flow in trenches or be covered by backfill.

(3) Contractor must remove with due care, and store at City's request, any objects or material from the Project site that City will salvage or reuse at another location.

(4) If directed by Engineer, Contractor must promptly repair or replace any property damage, as specified by the Engineer. However, acting in its sole

discretion, City may elect to have the property damage remedied otherwise, and may deduct the cost to repair or replace the damaged property from payment otherwise due to Contractor.

(5) Contractor will not permit any structure or infrastructure to be loaded in a manner that will damage or endanger the integrity of the structure or infrastructure.

(B) **Securing Project Site.** After completion of Work each day, Contractor must secure the Project site and, to the extent feasible, make the area reasonably accessible to the public unless City approves otherwise. All excess materials and equipment not protected by approved traffic control devices must be relocated to the staging area or demobilized. Trench spoils must be hauled off the Project site daily and open excavations must be protected with steel plates. Contractor and Subcontractor personnel may not occupy or use the Project site for any purpose during non-Work hours, except as may be provided in the Contract Documents or pursuant to prior written authorization from City.

(C) **Unforeseen Conditions.** If Contractor encounters facilities, utilities, or other unknown conditions not shown on or reasonably inferable from the Plans or apparent from inspection of the Project site, Contractor must immediately notify the City and promptly submit a Request for Information to obtain further directions from the Engineer. Contractor must avoid taking any action which could cause damage to the facilities or utilities pending further direction from the Engineer. The Engineer's written response will be final and binding on Contractor. If the Engineer's subsequent direction to Contractor affects Contractor's cost or time to perform the Work, Contractor may submit a Change Order request as set forth in Article 6 above.

(D) **Support; Adjacent Properties.** Contractor must provide, install, and maintain all shoring, bracing, and underpinning necessary to provide support to City's property and adjacent properties and improvements thereon. Contractor must provide notifications to adjacent property owners as may be required by Laws. See also, Section 7.15, Trenching of Five Feet or More.

(E) **Notification of Property Damage.** Contractor must immediately notify the City of damage to any real or personal property resulting from Work on the Project. Contractor must immediately provide a written report to City of any such property damage in excess of \$500 (based on estimated cost to repair or replace) within 24 hours of the occurrence. The written report must include: (1) the location and nature of the damage, and the owner of the property, if known; (2) the name and address of each employee of Contractor or any Subcontractor involved in the damage; (3) a detailed description of the incident, including precise location, time, and names and contact information for known witnesses; and (4) a police or first responder report, if applicable. If Contractor is required to file an accident report with another government agency, Contractor will provide a copy of the report to City.

7.6 Materials and Equipment.

(A) **General.** Unless otherwise specified, all materials and equipment required for the Work must be new, free from defects, and of the best grade for the intended purpose, and furnished in sufficient quantities to ensure the proper and expeditious performance of the Work. Contractor must employ measures to preserve the specified quality and fitness of the materials and equipment. Unless otherwise specified, all materials and equipment required for the Work are deemed to include all components required for complete installation and intended operation and must be installed in accordance with the manufacturer's recommendations or instructions. Contractor is responsible for all shipping, handling, and storage costs associated with the materials and equipment

required for the Work. Contractor is responsible for providing security and protecting the Work and all of the required materials, supplies, tools and equipment at Contractor's sole cost until City has formally accepted the Project as set forth in Section 11.1, Final Completion. Contractor will not assign, sell, mortgage, or hypothecate any materials or equipment for the Project, or remove any materials or equipment that have been installed or delivered.

(B) **City-Provided.** If the Work includes installation of materials or equipment to be provided by City, Contractor is solely responsible for the proper examination, handling, storage, and installation in accordance with the Contract Documents. Contractor must notify City of any defects discovered in City-provided materials or equipment, sufficiently in advance of scheduled use or installation to afford adequate time to procure replacement materials or equipment as needed. Contractor is solely responsible for any loss of or damage to such items which occurs while the items are in Contractor's custody and control, the cost of which may be offset from the Contract Price and deducted from any payment(s) due to Contractor.

(C) **Existing City Equipment.** Contractor will carefully remove all existing equipment from the Worksite. If the City specifies or indicates that equipment is to be salvaged and reused or to remain the property of City then the Contractor will reuse or return the equipment to the City. Contractor will store and protect salvaged equipment specified to be reused in the Work. Contractor will deliver to the City in good condition the equipment that is to remain City property but not be reused in the Work.

- (1) If an item specified to be salvaged is damaged during its removal, storage, or handling through carelessness or improper procedures, then Contractor will replace that equipment in kind or with a new item. For those items specified to be salvaged Contractor may choose to instead furnish and install new equipment, in which case the original, removed items will become Contractor's property. Existing materials and equipment removed by Contractor will only be reused in the Work if so specified or indicated by the City.

(D) **Intellectual Property Rights.** Contractor must, at its sole expense, obtain any authorization or license required for use of patented or copyright-protected materials, equipment, devices, or processes that are incorporated into the Work. Contractor's indemnity obligations in Article 4 apply to any claimed violation of intellectual property rights.

(E) **Certificate of Compliance.** When a Certificate of Compliance is specified, or for any material or item ("material") produced or assembled outside of the United States, Contractor must submit a Certificate of Compliance before incorporating that material into the Project. A Certificate of Compliance must be submitted for each lot of material delivered to the Project site, and in a form acceptable to the City Engineer, identifying the material, its source, and the lot. Each Certificate of Compliance must be signed by the material producer stating that the material fully complies with the applicable requirements of the Specifications. Submission of a Certificate of Compliance will not limit Contractor's continuing obligation to use only materials that conform with the requirements of the Contract Documents. Any materials furnished pursuant to a Certificate of Compliance may be inspected or tested at any time by City, subject to the inspection and testing provisions of Article 7, and defective or non-conforming material may be rejected at any time, even if already installed.

(F) **Site Materials.** Except as otherwise specified, City retains full ownership of and all rights to use any water, soil, stone, gravel, sand, minerals or other materials ("Site Materials") on City property, including the Project site, and including any site materials

that have been extracted, excavated, or otherwise affected or made accessible by performance of the Work. However, City, acting in its sole discretion, may provide written authorization in the Special Conditions or in the Specifications or in a Change Order for Contractor to make use of or incorporate specified Site Materials in the Work.

(G) **Mined Materials.** Pursuant to the Surface Mining and Reclamation Act of 1975, Public Resources Code § 2710 et seq., any purchase of mined materials, such as construction aggregate, sand, gravel, crushed stone, road base, fill materials, and any other mineral materials must originate from a surface mining operation included on the AB 3098 List, which is available online at:
<http://ftp.consrv.ca.gov/pub/omr/AB3098%20List/AB3908List.pdf>

7.7 Substitutions.

(A) **“Or Equal.”** Any Specification designating a material, product, or thing (collectively, “item”) or service by specific brand or trade name, followed by the words “or equal,” is intended only to indicate the quality and type of item or service desired, and Contractor may request use of any equal item or service. Unless otherwise stated in the Specifications, any reference to a specific brand or trade name for an item or service that is used solely for the purpose of describing the type of item or service desired, will be deemed to be followed by the words “or equal.” A substitution will only be approved if it is a true “equal” item or service in every aspect of design, function, and quality, as determined by City, including dimensions, weight, maintenance requirements, durability, fit with other elements, and schedule impacts.

(B) **Request for Substitution.** A post-award request for substitution of an item or service must be submitted in writing to the Engineer for approval in advance, within the applicable time period provided in the Contract Documents. If no time period is specified, the substitution request may be submitted any time within 35 days after the date of award of the Contract, or sufficiently in advance of the time needed to avoid delay of the Work, whichever is earlier.

(C) **Substantiation.** Any available data substantiating the proposed substitute as an equal item or service must be submitted with the written request for substitution. Contractor’s failure to timely provide all necessary substantiation, including any required test results as soon as they are available, is grounds for rejection of the proposed substitution, without further review.

(D) **Burden of Proving Equality.** Contractor has the burden of proving the equality of the proposed substitution at Contractor’s sole cost. City has sole discretion to determine whether a proposed substitution is equal, and City’s determination is final.

(E) **Approval or Rejection.** If the proposed substitution is approved, Contractor is solely responsible for any additional costs or time associated with the substituted item or service. If the proposed substitution is rejected, Contractor must, without delay, install the item or use the service as specified by City.

(F) **Contractor’s Obligations.** City’s approval of a proposed substitution will not relieve Contractor from any of its obligations under the Contract Documents. In the event Contractor makes an unauthorized substitution, Contractor will be solely responsible for all resulting cost impacts, including the cost of removal and replacement and the impact to other design elements.

7.8 Testing and Inspection.

(A) **General.** All materials, equipment, and workmanship used in the Work are subject to inspection and testing by City at all times and at all locations during construction and/or fabrication, including at any Worksite, shops, and yards. All manufacturers' application or installation instructions must be provided to the Inspector at least ten days prior to the first such application or installation. Contractor must, at all times, make the Work available for testing or inspection. Neither City's inspection or testing of Work, nor its failure to do so, operate to waive or limit Contractor's duty to complete the Work in accordance with the Contract Documents.

(B) **Scheduling and Notification.** Contractor must cooperate with City in coordinating the inspections and testing. Contractor must submit samples of materials, at Contractor's expense, and schedule all tests required by the Contract Documents in time to avoid any delay to the progress of the Work. Contractor must notify the Engineer no later than noon of the Working Day before any inspection or testing and must provide timely notice to the other necessary parties as specified in the Contract Documents. If Contractor schedules an inspection or test beyond regular Work hours, or on a Saturday, Sunday, or recognized City holiday, Contractor must notify the Engineer at least two Working Days in advance for approval. If approved, Contractor must reimburse City for the cost of the overtime inspection or testing. Such costs, including the City's hourly costs for required personnel, may be deducted from payments otherwise due to Contractor.

(C) **Responsibility for Costs.** City will bear the initial cost of inspection and testing to be performed by independent consultants retained by City, subject to the following exceptions:

(1) Contractor will be responsible for the costs of any subsequent inspections or tests which are required to substantiate compliance with the Contract Documents, and any associated remediation costs.

(2) Contractor will be responsible for inspection costs, at City's hourly rates, for inspection time lost because the Work is not ready, or Contractor fails to appear for a scheduled inspection.

(3) If any portion of the Work that is subject to inspection or testing is covered or concealed by Contractor prior to the inspection or testing, Contractor will bear the cost of making that portion of the Work available for the inspection or testing required by the Contract Documents, and any associated repair or remediation costs.

(4) Contractor is responsible for properly shoring all compaction test sites deeper than five feet below grade, as required under Section 7.15 below.

(5) Any Work or material that is defective or fails to comply with the requirements of the Contract Documents must be promptly repaired, removed, replaced, or corrected by Contractor, at Contractor's sole expense, even if that Work or material was previously inspected or included in a progress payment.

(D) **Contractor's Obligations.** Contractor is solely responsible for any delay occasioned by remediation of defective or noncompliant Work or material. Inspection or testing of the Work does not in any way relieve Contractor of its obligations to perform the Work as specified. Any Work done without the inspection(s) or testing required by the Contract Documents will be subject to rejection by City.

(E) **Distant Locations.** If required off-site testing or inspection must be conducted at a location more than 100 miles from the Project site, Contractor is solely responsible for the additional travel costs required for testing and/or inspection at such locations.

(F) **Plant Inspection.** If specified in the Contract Documents, or upon written request by City, Contractor must use its best efforts to facilitate and arrange for City's inspection, sampling or testing of materials or items required for the Work at the plant or facility from which the materials or items are to be obtained. Contractor's best efforts must include contacting the producer or manufacturer on a timely basis to schedule inspection by City's selected representative, including appropriate access and any safety equipment, all at no cost to City. The inspection must be scheduled sufficiently in advance of the planned shipping or production date to allow for alternative arrangements if the City determined that the materials or items do not meet the requirements of the Specifications. Nothing in this provision obligates City to inspect materials or items at the source plant or facility.

(F) **Final Inspection.** The provisions of this Section 7.8 also apply to final inspection under Article 11, Completion and Warranty Provisions.

7.9 Project Site Conditions and Maintenance. Contractor must at all times, on a 24-hour basis and at its sole cost, maintain the Project site and staging and storage areas in clean, neat, and sanitary condition and in compliance with all Laws pertaining to safety, air quality, and dust control. Adequate toilets must be provided, and properly maintained and serviced for all workers on the Project site, located in a suitably secluded area, subject to City's prior approval. Contractor must also, on a daily basis and at its sole cost, remove and properly dispose of the debris and waste materials from the Project site.

(A) **Protection of Existing Property, Structures, and Utilities.** If the Specifications indicate existing above-grade and below-grade structures, drainage lines, storm drains, sewers, water, gas, electrical, phone and data cable, and other similar items or utilities known to the City, then Contractor will locate these known existing installations before proceeding with trenching or other operations which may cause damage, will maintain them in service where appropriate, and will repair any damage caused to them by the Work, at no increase in the Contract Price.

(1) Contractor may temporarily mark or paint the ground, pavement, sidewalk, or any other improvements, but must not do so in a public right-of-way or on the Project site more than 30 days prior to the commencement of excavation work performed in connection with an installation. Any mark or paint must be removed from all surfaces, including any decorative work, within 30 days of the completion of the excavation work. Contractor is responsible for any expense associated with damages caused by the Contractor's mark or paint, including the removal thereof.

(2) Contractor will record the location and existence of pavement markers and striping prior to construction and will provide such records to the City Engineer. Contractor will replace in-kind any permanent paving marker or striping that it removes or damages, or as marked in the Specifications, at its expense.

(B) **Air Emissions Control.** Contractor must not discharge smoke or other air contaminants into the atmosphere in violation of any Laws. Contractor must comply with all Laws, including the California Air Resources Board's In-Use Off-Road Diesel-Fueled Fleets Regulation (13 CCR § 2449 et seq.).

(C) **Dust and Debris.** Contractor must minimize and confine dust and debris resulting from the Work. Contractor must abate dust nuisance by cleaning, sweeping, and immediately sprinkling with water excavated areas of dirt or other materials prone to cause dust, and within one hour after the Engineer notifies Contractor that an airborne nuisance exists. The Engineer may direct that Contractor provide an approved water-

spraying truck for this purpose. If water is used for dust control, Contractor will only use the minimum necessary. Contractor must take all necessary steps to keep waste water out of streets, gutters, or storm drains. See Section 7.19, Environmental Control. If City determines that the dust control is not adequate, City may have the work done by others and deduct the cost from the Contract Price. Contractor will immediately remove any excess excavated material from the Project site and any dirt deposited on public streets.

(D) **Clean up.** Before discontinuing Work in an area, Contractor must clean the area and remove all debris and waste along with the construction equipment, tools, machinery, and surplus materials.

(1) Except as otherwise specified, all excess Project materials, and the materials removed from existing improvements on the Project site with no salvage value or intended reuse by City, will be Contractor's property.

(2) Hauling trucks and other vehicles leaving the Project site must be cleaned of exterior mud or dirt before traveling on City streets. Materials and loose debris must be delivered and loaded to prevent dropping materials or debris. Contractor must immediately remove spillage from hauling on any publicly traveled way. Streets affected by Work on the Project must be kept clean by street sweeping.

(E) **Disposal.** Contractor must dispose of all Project debris and waste materials in a safe and legal manner. Contractor may not burn or bury waste materials on the Project site. Contractor will not allow any dirt, refuse, excavated material, surplus concrete or mortar, or any associated washings, to be disposed of onto streets, into manholes or into the storm drain system.

(E) **Completion.** At the completion of the Work, Contractor must remove from the Project site all of its equipment, tools, surplus materials, waste materials and debris, presenting a clean and neat appearance. Before demobilizing from the Project site, Contractor must ensure that all surfaces are cleaned, sealed, waxed, or finished as applicable, and that all marks, stains, paint splatters, and the like have been properly removed from the completed Work and the surrounding areas. Contractor must ensure that all parts of the construction are properly joined with the previously existing and adjacent improvements and conditions. Contractor must provide all cutting, fitting and patching needed to accomplish that requirement. Contractor must also repair or replace all existing improvements that are damaged or removed during the Work, both on and off the Project site, including curbs, sidewalks, driveways, fences, signs, landscaping, utilities, street surfaces and structures. Repairs and replacements must be at least equal to the previously existing improvements, and the condition, finish and dimensions must match the previously existing improvements. Contractor must restore to original condition all property or items that are not designated for alteration under the Contract Documents and leave each Worksite clean and ready for occupancy or use by City.

(F) **Non-Compliance.** If Contractor fails to comply with its maintenance and cleanup obligations or any City clean up order, City may, acting in its sole discretion, elect to suspend the Work until the condition(s) is corrected with no increase in the Contract Time or Contract Price, or undertake appropriate cleanup measures without further notice and deduct the cost from any amounts due or to become due to Contractor.

7.10 Instructions and Manuals. Contractor must provide to City one hard copy and one electronic file in PDF format of all instructions and manuals required by the Contract Documents, unless otherwise specified. These must be complete as to drawings, details, parts lists, performance data, and other information that may be required for City to easily maintain and service the materials and equipment installed for this Project.

(A) **Submittal Requirements.** The instructions and manuals, along with any required guarantees, must be delivered to City for review prior to requesting final inspection pursuant to Section 11.1(A), unless otherwise specified.

(B) **Training.** Contractor or its Subcontractors must train City's personnel in the operation and maintenance of any complex equipment or systems as a condition precedent to Final Completion, if required in the Contract Documents.

7.11 As-built Drawings. Contractor and its Subcontractors must prepare and maintain at the Project site a detailed, complete and accurate as-built set of the Plans which will be used solely for the purpose of recording changes made in any portion of the original Plans in order to create accurate record drawings at the end of the Project.

(A) **Duty to Update.** The as-built drawings must be updated as changes occur, on a daily basis if necessary. City may withhold the estimated cost for City to have the as-built drawings prepared from payments otherwise due to Contractor, until the as-built drawings are brought up to date to the satisfaction of City. Actual locations to scale must be identified on the as-built drawings for all runs of mechanical and electrical work, including all site utilities installed underground, in walls, floors, or otherwise concealed. Deviations from the original Plans must be shown in detail. The exact location of all main runs, whether piping, conduit, ductwork or drain lines, must be shown by dimension and elevation. The location of all buried pipelines, appurtenances, or other improvements must be represented by coordinates and by the horizontal distance from visible above-ground improvements.

(B) **Final Completion.** Contractor must verify that all changes in the Work are depicted in the as-built drawings and must deliver the complete set of as-built drawings to the Engineer for review and acceptance as a condition precedent to Final Completion and Final Payment.

7.12 Existing Utilities.

(A) **General.** The Work may be performed in developed, urban areas with existing utilities, both above and below ground, including utilities identified in the Contract Documents or in other informational documents or records. Contractor must take due care to locate identified or reasonably identifiable utilities before proceeding with trenching, excavation, or any other activity that could damage or disrupt existing utilities. This may include excavation with small equipment, potholing, or hand excavation, and, if practical, using white paint or other suitable markings to delineate the area to be excavated. Except as otherwise provided herein, Contractor will be responsible for costs resulting from damage to identified or reasonably identifiable utilities due to Contractor's negligence or failure to comply with the Contract Documents, including the requirements in this Article 7.

(B) **Unidentified Utilities.** Pursuant to Government Code § 4215, if, during the performance of the Work, Contractor discovers utility facilities not identified by City in the Contract Documents, Contractor must immediately provide written notice to City and the utility. City assumes responsibility for the timely removal, relocation, or protection of existing main or trunkline utility facilities located on the Project site if those utilities are not identified in the Contract Documents. Contractor will be compensated in accordance with the provisions of the Contract Documents for the costs of locating, repairing damage not due to Contractor's failure to exercise reasonable care, and removing or relocating utility facilities not indicated in the Plans or Specifications with reasonable accuracy, and for equipment on the Project necessarily idled during such work. Contractor will not be assessed liquidated damages for delay in completion of the Work, to the extent the delay was caused by City's failure to provide for removal or relocation of the utility facilities.

- 7.13 Notice of Excavation.** Contractor must comply with all applicable requirements in Government Code § 4216 et seq., which are incorporated by reference herein.
- 7.14 Trenching and Excavations of Four Feet or More.** As required by Public Contract Code § 7104, if the Work includes digging trenches or other excavations that extend deeper than four feet below the surface, the provisions in this Section apply to the Work and the Project.
- (A) **Duty to Notify.** Contractor must promptly, and before the following conditions are disturbed, provide written notice to City if Contractor finds any of the following conditions:
- (1) Material that Contractor believes may be a hazardous waste, as defined in § 25117 of the Health and Safety Code, that is required to be removed to a Class I, Class II, or Class III disposal site in accordance with the provisions of existing Laws;
 - (2) Subsurface or latent physical conditions at the Project site differing from those indicated by information about the Project site made available to bidders prior to the deadline for submitting bids; or
 - (3) Unknown physical conditions at the Project site of any unusual nature, materially different from those ordinarily encountered and generally recognized as inherent in work of the character required by the Contract Documents.
- (B) **City Investigation.** City will promptly investigate the conditions and if City finds that the conditions materially differ from those indicated, apparent, or reasonably inferred from information about the Project site made available to bidders, or involve hazardous waste, and cause a decrease or increase in Contractor's cost of, or the time required for, performance of any part of the Work, City will issue a Change Order.
- (C) **Disputes.** In the event that a dispute arises between City and Contractor regarding any of the conditions specified in subsection (B) above, or the terms of a Change Order issued by City, Contractor will not be excused from completing the Work within the Contract Time, but must proceed with all Work to be performed under the Contract. Contractor will retain any and all rights provided either by the Contract or by Laws which pertain to the resolution of disputes between Contractor and City.
- 7.15 Trenching of Five Feet or More.** As required by Labor Code § 6705, if the Contract Price exceeds \$25,000 and the Work includes the excavation of any trench or trenches of five feet or more in depth, a detailed plan must be submitted to City for acceptance in advance of the excavation. The detailed plan must show the design of shoring, bracing, sloping, or other provisions to be made for worker protection from the hazard of caving ground during the excavation. If the plan varies from the shoring system standards, it must be prepared by a California registered civil or structural engineer. Use of a shoring, sloping, or protective system less effective than that required by the Construction Safety Orders is prohibited.
- 7.16 New Utility Connections.** Except as otherwise specified, City will pay connection charges and meter costs for new permanent utilities required by the Contract Documents, if any. Contractor must notify City sufficiently in advance of the time needed to request service from each utility provider so that connections and services are initiated in accordance with the Project schedule.

7.17 Lines and Grades. Contractor is required to use any benchmark provided by the Engineer. Unless otherwise specified in the Contract Documents, Contractor must provide all lines and grades required to execute the Work. Contractor must also provide, preserve, and replace if necessary, all construction stakes required for the Project. All stakes or marks must be set by a California licensed surveyor or a California registered civil engineer. Contractor must notify the Engineer of any discrepancies found between Contractor's staking and grading and information provided by the Contract Documents. Upon completion, all Work must conform to the lines, elevations, and grades shown in the Plans, including any changes directed by a Change Order.

7.18 Historic or Archeological Items.

(A) **Contractor's Obligations.** Contractor must ensure that all persons performing Work at the Project site are required to immediately notify the Project Manager, upon discovery of any potential historic or archeological items, including historic or prehistoric ruins, a burial ground, archaeological or vertebrate paleontological site, including fossilized footprints or other archeological, paleontological or historical feature on the Project site (collectively, "Historic or Archeological Items").

(B) **Discovery; Cessation of Work.** Upon discovery of any potential Historic or Archeological Items, Work must be stopped within an 85-foot radius of the find and may not resume until authorized in writing by City. If required by City, Contractor must assist in protecting or recovering the Historic or Archeological Items, with any such assistance to be compensated as Extra Work on a time and materials basis under Article 6, Contract Modification. At City's discretion, a suspension of Work required due to discovery of Historic or Archeological Items may be treated as Excusable Delay pursuant to Article 5, or as a suspension for convenience under Article 13.

7.19 Environmental Control. Contractor must not pollute any drainage course or its tributary inlets with fuels, oils, bitumens, acids, insecticides, herbicides or other harmful materials. Contractor must prevent the release of any hazardous material or hazardous waste into the soil or groundwater, and prevent the unlawful discharge of pollutants into City's storm drain system and watercourses as required below. Contractor and its Subcontractors must at all times in the performance of the Work comply with all Laws concerning pollution of waterways.

(A) **Stormwater Permit.** Contractor must comply with all applicable conditions of the State Water Resources Control Board National Pollutant Discharge Elimination System General Permit for Waste Discharge Requirements for Discharges of Stormwater Runoff Associated with Construction Activity ("Stormwater Permit").

(B) **Contractor's Obligations.** If required for the Work, a copy of the Stormwater Permit is on file in City's principal administrative offices, and Contractor must comply with it without adjustment of the Contract Price or the Contract Time. Contractor must timely and completely submit required reports and monitoring information required by the conditions of the Stormwater Permit. Contractor also must comply with all other Laws governing discharge of stormwater, including applicable municipal stormwater management programs.

7.20 Noise Control. Contractor must comply with all applicable noise control Laws. Noise control requirements apply to all equipment used for the Work or related to the Work, including trucks, transit mixers or transient equipment that may or may not be owned by Contractor.

7.21 Mined Materials. Pursuant to Public Contract Code § 20676, Contractor will not purchase any sand, gravel, or other minerals for the Work from an operation subject to

the Surface Mining and Reclamation Act of 1975 (Public Resources Code § 2710 et seq.) unless the Contractor certifies, under penalty of perjury, that the minerals are from a mining operation included on the AB 3098 List, which may be accessed online at: <https://www.conservation.ca.gov/smgb/Pages/AB-3098-List.aspx>.

Article 8 - Payment

8.1 Schedule of Values. Prior to submitting its first application for payment, Contractor must prepare and submit to the Project Manager a schedule of values apportioned to the various divisions and phases of the Work, including mobilization and demobilization. If a Bid Schedule was submitted with Contractor's bid, the amounts in the schedule of values must be consistent with the Bid Schedule. Each line item contained in the schedule of values must be assigned a value such that the total of all items equals the Contract Price. The items must be sufficiently detailed to enable accurate evaluation of the percentage of completion claimed in each application for payment, and the assigned value consistent with any itemized or unit pricing submitted with Contractor's bid.

(A) **Measurements for Unit Price Work.** Materials and items of Work to be paid for on the basis of unit pricing will be measured according to the methods specified in the Contract Documents.

(C) **Deleted or Reduced Work.** Contractor will not be compensated for Work that City has deleted or reduced in scope, except for any labor, material, or equipment costs for such Work that Contractor reasonably incurred before Contractor learned that the Work could be deleted or reduced. Contractor will only be compensated for those actual, direct and documented costs incurred, and will not be entitled to any mark up for overhead or lost profits.

8.2 Progress Payments. Following the last day of each month, or as otherwise required by the Special Conditions or Specifications, Contractor will submit to the Project Manager for approval, a monthly application for payment for Work performed during the preceding month based on the estimated value of the Design Services or Construction Services performed during that preceding month.

(A) **Application for Payment.** Each application for payment for Construction Services must be itemized to include labor, materials, and equipment incorporated into the Work, and materials and equipment delivered to the Project site, as well as authorized and approved Change Orders. Each application for payment for Construction Services must be supported by Contractor's schedule of values and any other substantiating data required by the Contract Documents. If requested by the Project Manager, each application for payment for Construction Services must also be accompanied by an executed Conditional Waiver and Release Upon Progress Payment, using the form specified in Civil Code § 8132 for each Subcontractor that performed Work during the period covered by that application. The application for payment for Construction Services must also include the monthly report documenting compliance with the Skilled and Trained Workforce requirements pursuant to Public Contract Code § 2602, and as specified in Section 9.6, below.

(B) Payment of Undisputed Amounts.

(1) City will pay the undisputed amount due, as certified by the Project Manager, within 30 days after Contractor has submitted a complete and accurate payment application, subject to Public Contract Code § 20104.50. City will deduct a percentage from each progress payment as retention, as set forth in Section 8.6, below, and may withhold additional amounts as set forth in Section 8.4, below.

- (2) If required by the Project Manager, within 45 days after receipt of each payment from City for Construction Services, Contractor must submit an executed Unconditional Waiver and Release Upon Progress Payment, using the form specified in Civil Code § 8134, from each Subcontractor that has received a progress payment from Contractor following DBE's receipt of payment from City.

8.3 Adjustment of Payment Application. City may adjust or reject the amount requested in a payment application, including application for Final Payment, in whole or in part, if the amount requested is disputed or unsubstantiated. Contractor will be notified in writing of the basis for the modification to the amount requested. City may also deduct or withhold from payment otherwise due based upon any of the circumstances and amounts listed below. Sums withheld from payment otherwise due will be released when the basis for that withholding has been remedied and no longer exists.

- (A) For Contractor's unexcused failure to perform the Work as required by the Contract Documents, including correction or completion of punch list items, City may withhold or deduct an amount based on the City's estimated cost to correct or complete the Work.
- (B) For loss or damage caused by Contractor or its Subcontractors arising out of or relating to performance of the Work or any failure to protect the Project site, City may deduct an amount based on the estimated cost to repair or replace.
- (C) For Contractor's failure to pay its Subcontractors and suppliers when payment is due, City may withhold an amount equal to the total of past due payments and may opt to pay that amount separately via joint check pursuant to Section 8.6(B), Joint Checks.
- (D) For Contractor's failure to timely correct rejected, nonconforming, or defective Work, City may withhold or deduct an amount based on the City's estimated cost to correct or complete the Work.
- (E) For any unreleased stop notice, City may withhold 125% of the amount claimed.
- (F) For Contractor's failure to submit any required schedule or schedule update in the manner specified or within the time specified in the Contract Documents, City may withhold an amount equal to five percent of the total amount requested until Contractor complies with its schedule submittal obligations.
- (G) For Contractor's failure to maintain or submit as-built documents in the manner specified or within the time specified in the Contract Documents, City may withhold or deduct an amount based on the City's cost to prepare the as-builts.
- (H) For Work performed without Shop Drawings that have been accepted by City, when accepted Shop Drawings are required before proceeding with the Work, City may deduct an amount based on the estimated cost to correct unsatisfactory Work or diminution in value.
- (I) For fines, payments, or penalties assessed under the Labor Code, City may deduct from payments due to Contractor as required by Laws and as directed by the Division of Labor Standards Enforcement.
- (J) For any other fines, payments, or penalties assessed against the City relating to Contractor's acts or omissions, including violations of Laws, City may withhold or deduct such amounts from payment otherwise due to Contractor.

(K) For any other costs or charges that may be withheld or deducted from payments to Contractor, as provided in the Contract Documents, including liquidated damages, City may withhold or deduct such amounts from payment otherwise due to Contractor.

8.4 Early Occupancy. Neither City's payment of progress payments nor its partial or full use or occupancy of the Project constitutes acceptance of any part of the Work.

8.5 Retention. City will retain five percent of the full amount due on each progress payment (i.e., the amount due before any withholding or deductions pursuant to Section 8.3, Adjustment of Payment Application), or the percentage stated in the Notice Inviting Bids, whichever is greater, as retention to ensure full and satisfactory performance of the Work. Contractor is not entitled to any reduction in the rate of withholding at any time, nor to release of any retention before 35 days following City's recordation of the Notice of Completion, subject to the terms of Public Contract Code § 7107.

(A) **Substitution of Securities.** As provided by Public Contract Code § 22300, Contractor may request in writing that it be allowed, at its sole expense, to substitute securities for the retention withheld by City. Any escrow agreement entered into pursuant to this provision must fully comply with Public Contract Code § 22300 and will be subject to approval as to form by City's legal counsel. If City exercises its right to draw upon such securities in the event of default pursuant to section (7) of the statutory Escrow Agreement for Security Deposits in Lieu of Retention, pursuant to subdivision (g) of Public Contract Code § 22300 ("Escrow Agreement"), and if Contractor disputes that it is in default, its sole remedy is to comply with the dispute resolution procedures in Article 12 and the provisions therein. It is agreed that for purposes of this paragraph, an event of default includes City's rights pursuant to these Contract Documents to withhold or deduct sums from retention, including withholding or deduction for liquidated damages, incomplete or defective Work, stop payment notices, or backcharges. It is further agreed that if any individual authorized to give or receive written notice on behalf of a party pursuant to section (10) of the Escrow Agreement are unavailable to give or receive notice on behalf of that party due to separation from employment, retirement, death, or other circumstances, the successor or delegee of the named individual is deemed to be the individual authorized to give or receive notice pursuant to section (10) of the Escrow Agreement.

(B) **Release of Undisputed Retention.** All undisputed retention, less any amounts that may be assessed as liquidated damages, retained for stop notices, or otherwise withheld pursuant to Section 8.3, Adjustment of Payment Application, will be released as Final Payment to Contractor no sooner than 35 days following recordation of the notice of completion, and no later than 60 days following acceptance of the Project by City's governing body or authorized designee pursuant to Section 11.1(C), Acceptance, or, if the Project has not been accepted, no later than 60 days after the Project is otherwise considered complete pursuant to Public Contract Code § 7107(c).

8.6 Payment to Subcontractors and Suppliers. Each month, Contractor must promptly pay each Subcontractor and supplier the value of the portion of labor, materials, and equipment incorporated into the Work or delivered to the Project site by the Subcontractor or supplier during the preceding month. Such payments must be made in accordance with the requirements of Laws pertaining to such payments, and those of the Contract Documents and applicable subcontract or supplier contract.

(A) **Withholding for Stop Notice.** Pursuant to Civil Code § 9358, City will withhold 125% of the amount claimed by an unreleased stop notice, a portion of which may be retained by City for the costs incurred in handling the stop notice claim, including attorneys' fees and costs, as authorized by law.

(B) **Joint Checks.** City reserves the right, acting in its sole discretion, to issue joint checks made payable to Contractor and a Subcontractor or supplier, if City determines this is necessary to ensure fair and timely payment for a Subcontractor or supplier who has provided services or goods for the Project. As a condition to release of payment by a joint check, the joint check payees may be required to execute a joint check agreement in a form provided or approved by the City Attorney's Office. The joint check payees will be jointly and severally responsible for the allocation and disbursement of funds paid by joint check. Payment by joint check will not be construed to create a contractual relationship between City and a Subcontractor or supplier of any tier beyond the scope of the joint check agreement.

8.7 Final Payment. Contractor's application for Final Payment must comply with the requirements for submitting an application for a progress payment as stated in Section 8.2, above. Corrections to previous progress payments, including adjustments to estimated quantities for unit priced items, may be included in the Final Payment. If Contractor fails to submit a timely application for Final Payment, City reserves the right to unilaterally process and issue Final Payment without an application from Contractor in order to close out the Project. For the purposes of determining the deadline for Claim submission pursuant to Article 12, the date of Final Payment is deemed to be the date that City acts to release undisputed retention as final payment to Contractor, or otherwise provides written notice to Contractor of Final Payment or that no undisputed funds remain available for Final Payment due to offsetting withholdings or deductions pursuant to Section 8.3, Adjustment of Payment Application. If the amount due from Contractor to City exceeds the amount of Final Payment, City retains the right to recover the balance from Contractor or its sureties.

8.8 Release of Claims. City may, at any time, require that payment of the undisputed portion of any progress payment or Final Payment be contingent upon Contractor furnishing City with a written waiver and release of all claims against City arising from or related to the portion of Work covered by those undisputed amounts subject to the limitations of Public Contract Code § 7100. Any disputed amounts may be specifically excluded from the release.

8.9 Warranty of Title. Contractor warrants that title to all work, materials, or equipment incorporated into the Work and included in a request for payment will pass over to City free of any claims, liens, or encumbrances upon payment to Contractor.

Article 9 - Labor Provisions

9.1 Discrimination Prohibited. Discrimination against any prospective or present employee engaged in the Work on grounds of race, color, ancestry, national origin, ethnicity, religion, sex, sexual orientation, age, disability, or marital status is strictly prohibited. Contractor and its Subcontractors are required to comply with all applicable Laws prohibiting discrimination, including the California Fair Employment and Housing Act (Govt. Code § 12900 et seq.), Government Code § 11135, and Labor Code §§ 1735, 1777.5, 1777.6, and 3077.5.

9.2 Labor Code Requirements.

(A) **Eight Hour Day.** Pursuant to Labor Code § 1810, eight hours of labor constitute a legal day's work under this Contract.

(B) **Penalty.** Pursuant to Labor Code § 1813, Contractor will forfeit to City as a penalty, the sum of \$25.00 for each day during which a worker employed by Contractor or any Subcontractor is required or permitted to work more than eight hours in any one

calendar day or more than 40 hours per calendar week, except if such workers are paid overtime under Labor Code § 1815.

(C) **Apprentices.** Contractor is responsible for compliance with the requirements governing employment and payment of apprentices, as set forth in Labor Code § 1777.5, which is fully incorporated by reference.

(D) **Notices.** Pursuant to Labor Code § 1771.4, Contractor is required to post all job site notices prescribed by Laws.

9.3 Prevailing Wages. Each worker performing Work under this Contract that is covered under Labor Code §§ 1720, 1720.3, or 1720.9, including cleanup at the Project site, must be paid at a rate not less than the prevailing wage as defined in §§ 1771 and 1774 of the Labor Code. The prevailing wage rates are on file with the City and available online at <http://www.dir.ca.gov/dlsr>. Contractor must post a copy of the applicable prevailing rates at the Project site.

(A) **Penalties.** Pursuant to Labor Code § 1775, Contractor and any Subcontractor will forfeit to City as a penalty up to \$200.00 for each calendar day, or portion thereof, for each worker paid less than the applicable prevailing wage rate. Contractor must also pay each worker the difference between the applicable prevailing wage rate and the amount actually paid to that worker.

(B) **Federal Requirements.** If this Project is subject to federal prevailing wage requirements in addition to California prevailing wage requirements, Contractor and its Subcontractors are required to pay the higher of the currently applicable state or federal prevailing wage rates.

9.4 Payroll Records. Contractor must comply with the provisions of Labor Code §§ 1771.4, 1776, and 1812 and all implementing regulations, which are fully incorporated by this reference, including requirements for monthly electronic submission of payroll records to the DIR.

(A) **Contractor and Subcontractor Obligations.** Contractor and each Subcontractor must keep accurate payroll records, showing the name, address, social security number, work classification, straight time and overtime hours worked each day and week, and the actual per diem wages paid to each journeyman, apprentice, worker, or other employee employed in connection with the Work. Each payroll record must contain or be verified by a written declaration that it is made under penalty of perjury, stating both of the following:

(1) The information contained in the payroll record is true and correct; and

(2) Contractor or the Subcontractor has complied with the requirements of Labor Code §§ 1771, 1811, and 1815 for any Work performed by its employees on the Project.

(B) **Certified Record.** A certified copy of an employee's payroll record must be made available for inspection or furnished to the employee or his or her authorized representative on request, to City, to the Division of Labor Standards Enforcement, to the Division of Apprenticeship Standards of the DIR, and as further required by the Labor Code.

(C) **Enforcement.** Upon notice of noncompliance with Labor Code § 1776, Contractor or Subcontractor has ten days in which to comply with the requirements of this section. If Contractor or Subcontractor fails to do so within the ten-day period, Contractor

or Subcontractor will forfeit a penalty of \$100.00 per day, or portion thereof, for each worker for whom compliance is required, until strict compliance is achieved. Upon request by the Division of Apprenticeship Standards, or the Division of Labor Standards Enforcement, these penalties will be withheld from payments then due to Contractor.

9.5 Labor Compliance. Pursuant to Labor Code § 1771.4, the Contract for this Project is subject to compliance monitoring and enforcement by the DIR.

9.6 Skilled and Trained Workforce. Contractor and its Subcontractors of every tier must use a Skilled and Trained Workforce, to perform all Work on the Project that falls within an apprenticeable occupation in the building and construction trades. Contractor will submit a report each month to the City demonstrating compliance with this requirement during the previous calendar month. The monthly report on compliance with Skilled and Trained Workforce compliance during the previous calendar month, must be submitted with Contractor's monthly application for progress payments.

Article 10 - Safety Provisions

10.1 Safety Precautions and Programs. Contractor and its Subcontractors are fully responsible for safety precautions and programs, and for the safety of persons and property in the performance of the Work. Contractor and its Subcontractors must at all times comply with all applicable health and safety Laws and seek to avoid injury, loss, or damage to persons or property by taking reasonable steps to protect its employees and other persons at any Worksite, materials and equipment stored on or off site, and property at or adjacent to any Worksite.

(A) **Reporting Requirements.** Contractor must immediately notify the City of any death, serious injury or illness resulting from Work on the Project. Contractor must immediately provide a written report to City of each recordable accident or injury occurring at any Worksite within 24 hours of the occurrence. The written report must include: (1) the name and address of the injured or deceased person; (2) the name and address of each employee of Contractor or of any Subcontractor involved in the incident; (3) a detailed description of the incident, including precise location, time, and names and contact information for known witnesses; and (4) a police or first responder report, if applicable. If Contractor is required to file an accident report with a government agency, Contractor will provide a copy of the report to City.

(B) **Legal Compliance.** Contractor's safety program must comply with the applicable legal and regulatory requirements. Contractor must provide City with copies of all notices required by Laws.

(C) **Contractor's Obligations.** Any damage or loss caused by Contractor arising from the Work which is not insured under property insurance must be promptly remedied by Contractor.

(D) **Remedies.** If City determines, in its sole discretion, that any part of the Work or Project site is unsafe, City may, without assuming responsibility for Contractor's safety program, require Contractor or its Subcontractor to cease performance of the Work or to take corrective measures to City's satisfaction. If Contractor fails to promptly take the required corrective measures, City may perform them and deduct the cost from the Contract Price. Contractor agrees it is not entitled to submit a Claim for damages, for an increase in Contract Price, or for a change in Contract Time based on Contractor's compliance with City's request for corrective measures pursuant to this provision.

- 10.2 Hazardous Materials.** Unless otherwise specified in the Contract Documents, this Contract does not include the removal, handling, or disturbance of any asbestos or other Hazardous Materials. If Contractor encounters materials on the Project site that Contractor reasonably believes to be asbestos or other Hazardous Materials, and the asbestos or other Hazardous Materials have not been rendered harmless, Contractor may continue Work in unaffected areas reasonably believed to be safe, but must immediately cease work on the area affected and report the condition to City. No asbestos, asbestos-containing products or other Hazardous Materials may be used in performance of the Work.
- 10.3 Material Safety.** Contractor is solely responsible for complying with § 5194 of Title 8 of the California Code of Regulations, including by providing information to Contractor's employees about any hazardous chemicals to which they may be exposed in the course of the Work. A hazard communication program and other forms of warning and training about such exposure must be used. Contractor must also maintain Safety Data Sheets ("SDS") at the Project site, as required by Laws, for materials or substances used or consumed in the performance of the Work. The SDS will be accessible and available to Contractor's employees, Subcontractors, and City.
- (A) **Contractor Obligations.** Contractor is solely responsible for the proper delivery, handling, use, storage, removal, and disposal of all materials brought to the Project site and/or used in the performance of the Work. Contractor must notify the Engineer if a specified product or material cannot be used safely.
- (B) **Labeling.** Contractor must ensure proper labeling on any material brought onto the Project site so that any persons working with or in the vicinity of the material may be informed as to the identity of the material, any potential hazards, and requirements for proper handling, protections, and disposal.
- 10.4 Hazardous Condition.** Contractor is solely responsible for determining whether a hazardous condition exists or is created during the course of the Work, involving a risk of bodily harm to any person or risk of damage to any property. If a hazardous condition exists or is created, Contractor must take all precautions necessary to address the condition and ensure that the Work progresses safely under the circumstances. Hazardous conditions may result from, but are not limited to, use of specified materials or equipment, the Work location, the Project site condition, the method of construction, or the way any Work must be performed.
- 10.5 Emergencies.** In an emergency affecting the safety or protection of persons, Work, or property at or adjacent to any Worksite, Contractor must take reasonable and prompt actions to prevent damage, injury, or loss, without prior authorization from the City if, under the circumstances, there is inadequate time to seek prior authorization from the City.

Article 11 - Completion and Warranty Provisions

11.1 Final Completion.

- (A) **Final Inspection and Punch List.** When the Work required by this Contract is fully performed, Contractor must provide written notification to City requesting final inspection. The Engineer will schedule the date and time for final inspection, which must include Contractor's primary representative for this Project and its superintendent. Based on that inspection, City will prepare a punch list of any items that are incomplete, missing, defective, incorrectly installed, or otherwise not compliant with the Contract Documents.

The punch list to Contractor will specify the time by which all of the punch list items must be completed or corrected. The punch list may include City's estimated cost to complete each punch list item if Contractor fails to do so within the specified time. The omission of any non-compliant item from a punch list will not relieve Contractor from fulfilling all requirements of the Contract Documents. Contractor's failure to complete any punch list item within the time specified in the punch list will not waive or abridge its warranty obligations for any such items that must be completed by the City or by a third party retained by the City due to Contractor's failure to timely complete any such outstanding item.

(B) **Requirements for Final Completion.** Final Completion will be achieved upon completion or correction of all punch list items, as verified by City's further inspection, and upon satisfaction of all other Contract requirements, including any commissioning required under the Contract Documents and submission of all final submittals, including instructions and manuals as required under Section 7.10, and complete, final as-built drawings as required under Section 7.11, all to City's satisfaction.

(C) **Acceptance.** The Project will be considered accepted upon City Council action during a public meeting to accept the Project, unless the Engineer is authorized to accept the Project, in which case the Project will be considered accepted upon the date of the Engineer's issuance of a written notice of acceptance. In order to avoid delay of Project close out, the City may elect, acting in its sole discretion, to accept the Project as complete subject to exceptions for punch list items that are not completed within the time specified in the punch list.

(D) **Final Payment and Release of Retention.** Final Payment and release of retention, less any sums withheld pursuant to the provisions of the Contract Documents, will not be made sooner than 35 days after recordation of the notice of completion. If Contractor fails to complete all of the punch list items within the specified time, City may withhold up to 150% of City's estimated cost to complete each of the remaining items from Final Payment and may use the withheld retention to pay for the costs to self-perform the outstanding items or to retain a third party to complete any such outstanding punch list item.

11.2 Warranty.

(A) **General.** Contractor warrants that all materials and equipment will be new unless otherwise specified, of good quality, in conformance with the Contract Documents, and free from defective workmanship and materials. Contractor further warrants that the Work will be free from material defects not intrinsic in the design or materials required in the Contract Documents. Contractor warrants that materials or items incorporated into the Work comply with the requirements and standards in the Contract Documents, including compliance with Laws, and that any Hazardous Materials encountered or used were handled as required by Laws. At City's request, Contractor must furnish satisfactory evidence of the quality and type of materials and equipment furnished. Contractor's warranty does not extend to damage caused by normal wear and tear, or improper use or maintenance.

(B) **Warranty Period.** Contractor's warranty must guarantee its Work for a period of one year from the date of Project acceptance (the "Warranty Period"), except when a longer guarantee is provided by a supplier or manufacturer or is required by the Specifications or Special Conditions. Contractor must obtain from its Subcontractors, suppliers and manufacturers any special or extended warranties required by the Contract Documents.

(C) **Warranty Documents.** As a condition precedent to Final Completion, Contractor must supply City with all warranty and guarantee documents relevant to equipment and materials incorporated into the Work and guaranteed by their suppliers or manufacturers.

(D) **Subcontractors.** The warranty obligations in the Contract Documents apply to Work performed by Contractor and its Subcontractors, and Contractor agrees to be co-guarantor of such Work.

(E) **Contractor's Obligations.** Upon written notice from City to Contractor of any defect in the Work discovered during the Warranty Period, Contractor or its responsible Subcontractor must promptly correct the defective Work at its own cost. Contractor's obligation to correct defects discovered during the Warranty Period will continue past the expiration of the Warranty Period as to any defects in Work for which Contractor was notified prior to expiration of the Warranty Period. Work performed during the Warranty Period ("Warranty Work") will be subject to the warranty provisions in this Section 11.2 for a one-year period that begins upon completion of such Warranty Work to City's satisfaction.

(F) **City's Remedies.** If Contractor or its responsible Subcontractor fails to correct defective Work within ten days following notice by City, or sooner if required by the circumstances, City may correct the defects to conform with the Contract Documents at Contractor's sole expense. Contractor must reimburse City for its costs in accordance with subsection (H), below.

(G) **Emergency Repairs.** In cases of emergency where any delay in correcting defective Work could cause harm, loss or damage, City may immediately correct the defects to conform with the Contract Documents at Contractor's sole expense. Contractor or its surety must reimburse City for its costs in accordance with subsection (H), below.

(H) **Reimbursement.** Contractor must reimburse City for its costs to repair under subsections (F) or (G), above, within 30 days following City's submission of a demand for payment pursuant to this provision. If City is required to initiate legal action to compel Contractor's compliance with this provision, and City is the prevailing party in such action, Contractor and its surety are solely responsible for all of City's attorney's fees and legal costs expended to enforce Contractor's warranty obligations herein, in addition to any and all costs City incurs to correct the defective Work.

11.3 Use Prior to Final Completion. City reserves the right to occupy or make use of the Project, or any portions of the Project, prior to Final Completion if City has determined that the Project or portion of it is in a condition suitable for the proposed occupation or use, and that it is in its best interest to occupy or make use of the Project, or any portions of it, prior to Final Completion. City will notify Contractor in writing of its intent to occupy or make use of the Project or any portions of the Project, pursuant to this provision.

(A) **Non-Waiver.** Occupation or use of the Project, in whole or in part, prior to Final Completion will not operate as acceptance of the Work or any portion of it, nor will it operate as a waiver of any of City's rights or Contractor's duties pursuant to these Contract Documents, and will not affect nor bear on the determination of the time of substantial completion with respect to any statute of repose pertaining to the time for filing an action for construction defect.

(B) **City's Responsibility.** City will be responsible for the cost of maintenance and repairs due to normal wear and tear with respect to those portions of the Project that are being occupied or used before Final Completion. The Contract Price or the Contract Time may be adjusted pursuant to the applicable provisions of these Contract Documents if,

and only to the extent that, any occupation or use under this Section actually adds to Contractor's cost or time to complete the Work within the Contract Time.

- 11.4 Substantial Completion.** For purposes of determining "substantial completion" with respect to any statute of repose pertaining to the time for filing an action for construction defect, "substantial completion" is deemed to mean the last date that Contractor or any Subcontractor performs Work on the Project prior to City acceptance of the Project, except for warranty work performed under this Article.

Article 12 - Dispute Resolution

- 12.1 Claims.** This Article applies to and provides the exclusive procedures for any Claim arising from or related to the Contract or performance of the Work.

(A) **Limitations.** A Claim may only include the portion of a previously rejected demand that remains in dispute between Contractor and City. With the exception of any dispute regarding the amount of money actually paid to Contractor as Final Payment, Contractor is not entitled to submit a Claim demanding a change in the Contract Time or the Contract Price, which has not previously been submitted to City in full compliance with Article 5 and Article 6, and subsequently rejected in whole or in part by City.

(B) **Scope of Article.** This Article is intended to provide the exclusive procedures for submission and resolution of Claims of any amount and applies in addition to the provisions of Public Contract Code § 9204 and § 20104 et seq., which are incorporated by reference herein.

(C) **No Work Delay.** Notwithstanding the submission of a Claim or any other dispute between the parties related to the Project or the Contract Documents, Contractor must perform the Work and may not delay or cease Work pending resolution of a Claim or other dispute, but must continue to diligently prosecute the performance and timely completion of the Work, including the Work pertaining to the Claim or other dispute.

(D) **Informal Resolution.** Contractor will make a good faith effort to informally resolve a dispute before initiating a Claim, preferably by face-to-face meeting between authorized representatives of Contractor and City.

- 12.2 Claims Submission.** The following requirements apply to any Claim subject to this Article:

(A) **Substantiation.** The Claim must be submitted to City in writing by registered or certified mail with return receipt requested and clearly identified as a "Claim" submitted pursuant to this Article 12. The Claim must include all of the documents necessary to substantiate the Claim including the Change Order request that was rejected in whole or in part, and a copy of City's written rejection that is in dispute. The Claim must clearly identify and describe the dispute, including relevant references to applicable portions of the Contract Documents, and a chronology of relevant events. Any Claim for additional payment must include a complete, itemized breakdown of all known or estimated labor, materials, taxes, insurance, and subcontract, or other costs. Substantiating documentation such as payroll records, receipts, invoices, or the like, must be submitted in support of each component of claimed cost. Any Claim for an extension of time or delay costs must be substantiated with a schedule analysis and narrative depicting and explaining claimed time impacts.

(B) **Claim Format and Content.** A Claim must be submitted in the following format:

(1) Provide a cover letter, specifically identifying the submission as a "Claim" submitted under this Article 12 and specifying the requested remedy (e.g., amount of proposed change to Contract Price and/or change to Contract Time).

(2) Provide a summary of each Claim, including underlying facts and the basis for entitlement, and identify each specific demand at issue, including the specific Change Order request (by number and submittal date), and the date of City's rejection of that demand, in whole or in part.

(3) Provide a detailed explanation of each issue in dispute. For multiple issues included within a single Claim or for multiple Claims submitted concurrently, separately number and identify each individual issue or Claim, and include the following for each separate issue or Claim:

a. A succinct statement of the matter in dispute, including Contractor's position and the basis for that position;

b. Identify and attach all documents that substantiate the Claim, including relevant provisions of the Contract Documents, RFIs, calculations, and schedule analysis (see subsection (A), Substantiation, above);

c. A chronology of relevant events; and

d. Analysis and basis for claimed changes to Contract Price, Contract Time, or any other remedy requested.

(4) Provide a summary of issues and corresponding claimed damages. If, by the time of the Claim submission deadline (below), the precise amount of the requested change in the Contract Price or Contract Time is not yet known, Contractor must provide a good faith estimate, including the basis for that estimate, and must identify the date by which it is anticipated that the Claim will be updated to provide final amounts.

(5) Include the following certification, executed by Contractor's authorized representative:

"The undersigned Contractor certifies under penalty of perjury that its statements and representations in this Claim submittal are true and correct. Contractor warrants that this Claim submittal is comprehensive and complete as to the matters in dispute, and agrees that any costs, expenses, or delay not included herein are deemed waived."

(C) **Submission Deadlines.**

(1) A Claim disputing rejection of a request for a change in the Contract Time or Contract Price must be submitted within 21 days following the date that City notified Contractor in writing that a request for a change in the Contract Time or Contract Price, duly submitted in compliance with Article 5 and Article 6, has been rejected in whole or in part. A Claim disputing the terms of a unilateral Change Order must be submitted within 21 days following the date of issuance of the unilateral Change Order. These Claim deadlines apply even if Contractor cannot yet quantify the total amount of any requested change in the Contract Time or Contract Price. If the Contractor cannot quantify those amounts, it must submit an estimate of the amounts claimed pending final determination of the requested remedy by Contractor.

(2) With the exception of any dispute regarding the amount of Final Payment, any Claim must be filed on or before the date of Final Payment or will be deemed waived.

(3) A Claim disputing the amount of Final Payment must be submitted within 21 days of the effective date of Final Payment, under Section 8.7, Final Payment.

(4) Strict compliance with these Claim submission deadlines is necessary to ensure that any dispute may be mitigated as soon as possible, and to facilitate cost-efficient administration of the Project. **Any Claim that is not submitted within the specified deadlines will be deemed waived by Contractor.**

12.3 City's Response. City will respond within 45 days of receipt of the Claim with a written statement identifying which portion(s) of the Claim are disputed, unless the 45-day period is extended by mutual agreement of City and Contractor or as otherwise allowed under Public Contract Code § 9204. However, if City determines that the Claim is not adequately substantiated pursuant to Section 12.2(A), Substantiation, City may first request in writing, within 30 days of receipt of the Claim, any additional documentation supporting the Claim or relating to defenses to the Claim that City may have against the Claim.

(A) **Additional Information.** If additional information is thereafter required, it may be requested and provided upon mutual agreement of City and Contractor. If Contractor's Claim is based on estimated amounts, Contractor has a continuing duty to update its Claim as soon as possible with information on actual amounts in order to facilitate prompt and fair resolution of the Claim.

(B) **Non-Waiver.** Any failure by City to respond within the times specified above will not be construed as acceptance of the Claim, in whole or in part, or as a waiver of any provision of these Contract Documents.

12.4 Meet and Confer. If Contractor disputes City's written response, or City fails to respond within the specified time, within 15 days of receipt of City's response or within 15 days of City's failure to respond within the applicable 45-day time period under Section 12.3, respectively, Contractor may notify City of the dispute in writing sent by registered or certified mail, return receipt requested, and demand an informal conference to meet and confer for settlement of the issues in dispute. If Contractor fails to notify City of the dispute and demand an informal conference to meet and confer in writing within the specified time, Contractor's Claim will be deemed waived.

(A) **Schedule Meet and Confer.** Upon receipt of the demand to meet and confer, City will schedule the meet and confer conference to be held within 30 days, or later if

needed to ensure the mutual availability of each of the individuals that each party requires to represent its interests at the meet and confer conference.

(B) **Location for Meet and Confer.** The meet and confer conference will be scheduled at a location at or near City's principal office.

(C) **Written Statement After Meet and Confer.** Within ten working days after the meet and confer has concluded, City will issue a written statement identifying which portion(s) of the Claim remain in dispute, if any.

(D) **Submission to Mediation.** If the Claim or any portion remains in dispute following the meet and confer conference, within ten working days after the City issues the written statement identifying any portion(s) of the Claim remaining in dispute, the Contractor may identify in writing disputed portion(s) of the Claim, which will be submitted for mediation, as set forth below.

12.5 Mediation and Government Code Claims.

(A) **Mediation.** Within ten working days after the City issues the written statement identifying any portion(s) of the Claim remaining in dispute following the meet and confer, City and Contractor will mutually agree to a mediator, as provided under Public Contract Code § 9204. Mediation will be scheduled to ensure the mutual availability of the selected mediator and all of the individuals that each party requires to represent its interests. If there are multiple Claims in dispute, the parties may agree to schedule the mediation to address all outstanding Claims at the same time. The parties will share the costs of the mediator and mediation fees equally, but each party is otherwise solely and separately responsible for its own costs to prepare for and participate in the mediation, including costs for its legal counsel or any other consultants.

(B) **Government Code Claims.**

(1) Timely presentation of a Government Code Claim is a condition precedent to filing any legal action based on or arising from the Contract. Compliance with the Claim submission requirements in this Article 12 is a condition precedent to filing a Government Code Claim.

(2) The time for filing a Government Code Claim will be tolled from the time Contractor submits its written Claim pursuant to Section 12.2, above, until the time that Claim is denied in whole or in part at the conclusion of the meet and confer process, including any period of time used by the meet and confer process. However, if the Claim is submitted to mediation, the time for filing a Government Code Claim will be tolled until conclusion of the mediation, including any continuations, if the Claim is not fully resolved by mutual agreement of the parties during the mediation or any continuation of the mediation.

12.6 Tort Claims. This Article does not apply to tort claims and nothing in this Article is intended nor will be construed to change the time periods for filing tort-based Government Code Claims.

12.7 Arbitration. It is expressly agreed, under Code of Civil Procedure § 1296, that in any arbitration to resolve a dispute relating to this Contract, the arbitrator's award must be supported by law and substantial evidence.

12.8 Burden of Proof and Limitations. Contractor bears the burden of proving entitlement to and the amount of any claimed damages. Contractor is not entitled to damages calculated on a total cost basis, but must prove actual damages. Contractor is not entitled

to speculative, special, or consequential damages, including home office overhead or any form of overhead not directly incurred at the Project site or any other Worksite; lost profits; loss of productivity; lost opportunity to work on other projects; diminished bonding capacity; increased cost of financing for the Project; extended capital costs; non-availability of labor, material or equipment due to delays; or any other indirect loss arising from the Contract. The Eichleay Formula or similar formula will not be used for any recovery under the Contract. The City will not be directly liable to any Subcontractor or supplier.

- 12.9 Legal Proceedings.** In any legal proceeding that involves enforcement of any requirements of the Contract Documents, the finder of fact will receive detailed instructions on the meaning and operation of the Contract Documents, including conditions, limitations of liability, remedies, claim procedures, and other provisions bearing on the defenses and theories of liability. Detailed findings of fact will be requested to verify enforcement of the Contract Documents. All of the City's remedies under the Contract Documents will be construed as cumulative, and not exclusive, and the City reserves all rights to all remedies available under law or equity as to any dispute arising from or relating to the Contract Documents or performance of the Work.
- 12.10 Other Disputes.** The procedures in this Article 12 will apply to any and all disputes or legal actions, in addition to Claims, arising from or related to this Contract, including disputes regarding suspension or early termination of the Contract, unless and only to the extent that compliance with a procedural requirement is expressly and specifically waived by City. Nothing in this Article is intended to delay suspension or termination under Article 13.

Article 13 - Suspension and Termination

- 13.1 Suspension for Cause.** In addition to all other remedies available to City, if Contractor fails to perform or correct Work in accordance with the Contract Documents, including non-compliance with applicable environmental or health and safety Laws, City may immediately order the Work, or any portion of it, suspended until the circumstances giving rise to the suspension have been eliminated to City's satisfaction.

(A) **Notice of Suspension.** Upon receipt of City's written notice to suspend the Work, in whole or in part, except as otherwise specified in the notice of suspension, Contractor and its Subcontractors must promptly stop Work as specified in the notice of suspension; comply with directions for cleaning and securing the Worksite; and protect the completed and in-progress Work and materials. Contractor is solely responsible for any damages or loss resulting from its failure to adequately secure and protect the Project.

(B) **Resumption of Work.** Upon receipt of the City's written notice to resume the suspended Work, in whole or in part, except as otherwise specified in the notice to resume, Contractor and its Subcontractors must promptly re-mobilize and resume the Work as specified; and within ten days from the date of the notice to resume, Contractor must submit a recovery schedule, prepared in accordance with the Contract Documents, showing how Contractor will complete the Work within the Contract Time.

(C) **Failure to Comply.** Contractor will not be entitled to an increase in the Contract Time or Contract Price for a suspension occasioned by Contractor's failure to comply with the Contract Documents.

(D) **No Duty to Suspend.** City's right to suspend the Work will not give rise to a duty to suspend the Work, and City's failure to suspend the Work will not constitute a defense to Contractor's failure to comply with the requirements of the Contract Documents.

13.2 Suspension for Convenience. City reserves the right to suspend, delay, or interrupt the performance of the Work in whole or in part, for a period of time determined to be appropriate for City's convenience. Upon notice by City pursuant to this provision, Contractor must immediately suspend, delay, or interrupt the Work and secure the Project site as directed by City except for taking measures to protect completed or in-progress Work as directed in the suspension notice, and subject to the provisions of Section 13.1(A) and (B), above. If Contractor submits a timely request for a Change Order in compliance with Articles 5 and 6, the Contract Price and the Contract Time will be equitably adjusted by Change Order pursuant to the terms of Articles 5 and 6 to reflect the cost and delay impact occasioned by such suspension for convenience, except to the extent that any such impacts were caused by Contractor's failure to comply with the Contract Documents or the terms of the suspension notice or notice to resume. However, the Contract Time will only be extended if the suspension causes or will cause unavoidable delay in Final Completion. If Contractor disputes the terms of a Change Order issued for such equitable adjustment due to suspension for convenience, its sole recourse is to comply with the Claim procedures in Article 12.

13.3 Termination for Default. City may declare that Contractor is in default of the Contract for a material breach of or inability to fully, promptly, or satisfactorily perform its obligations under the Contract.

(A) **Default.** Events giving rise to a declaration of default include Contractor's refusal or failure to supply sufficient skilled workers, proper materials, or equipment to perform the Work within the Contract Time; Contractor's refusal or failure to make prompt payment to its employees, Subcontractors, or suppliers or to correct defective Work or damage; Contractor's failure to comply with Laws, or orders of any public agency with jurisdiction over the Project; evidence of Contractor's bankruptcy, insolvency, or lack of financial capacity to complete the Work as required within the Contract Time; suspension, revocation, or expiration and nonrenewal of Contractor's license or DIR registration; dissolution, liquidation, reorganization, or other major change in Contractor's organization, ownership, structure, or existence as a business entity; unauthorized assignment of Contractor's rights or duties under the Contract; or any material breach of the Contract requirements.

(B) **Notice of Default and Opportunity to Cure.** Upon City's declaration that Contractor is in default due to a material breach of the Contract Documents, if City determines that the default is curable, City will afford Contractor the opportunity to cure the default within ten days of City's notice of default, or within a period of time reasonably necessary for such cure, including a shorter period of time if applicable.

(C) **Termination.** If Contractor fails to cure the default or fails to expediently take steps reasonably calculated to cure the default within the time period specified in the notice of default, City may issue written notice to Contractor and its performance bond surety of City's termination of the Contract for default.

(D) **Waiver.** Time being of the essence in the performance of the Work, if Contractor's surety fails to arrange for completion of the Work in accordance with the Performance Bond within seven calendar days from the date of the notice of termination pursuant to paragraph (C), City may immediately make arrangements for the completion of the Work through use of its own forces, by hiring a replacement contractor, or by any other means that City determines advisable under the circumstances. Contractor and its surety will be jointly and severally liable for any additional cost incurred by City to

complete the Work following termination, where “additional cost” means all cost in excess of the cost City would have incurred if Contractor had timely completed Work without the default and termination. In addition, City will have the right to immediate possession and use of any materials, supplies, and equipment procured for the Project and located at the Project site or any Worksite on City property for the purposes of completing the remaining Work.

(E) **Compensation.** Within 30 days of receipt of updated as-builts, all warranties, manuals, instructions, or other required documents for Work installed to date, and delivery to City of all equipment and materials for the Project for which Contractor has already been compensated, Contractor will be compensated for the Work satisfactorily performed in compliance with the Contract Documents up to the effective date of the termination pursuant to the terms of Article 8, Payment, subject to City’s rights to withhold or deduct sums from payment otherwise due pursuant to Section 8.3, and excluding any costs Contractor incurs as a result of the termination, including any cancellation or restocking charges or fees due to third parties. If Contractor disputes the amount of compensation determined by City, its sole recourse is to comply with the Claim Procedures in Article 12, by submitting a Claim no later than 30 days following notice from City of the total compensation to be paid by City.

(F) **Wrongful Termination.** If Contractor disputes the termination, its sole recourse is to comply with the Claim procedures in Article 12. If a court of competent jurisdiction or an arbitrator later determines that the termination for default was wrongful, the termination will be deemed to be a termination for convenience, and Contractor’s damages will be strictly limited to the compensation provided for termination for convenience under Section 13.4, below. Contractor waives any claim for any other damages for wrongful termination including special or consequential damages, lost opportunity costs, or lost profits, and any award of damages is subject to Section 12.8, Burden of Proof and Limitations.

13.4 Termination for Convenience. City reserves the right, acting in its sole discretion, to terminate all or part of the Contract for convenience upon written notice to Contractor.

(A) **Compensation to Contractor.** In the event of City’s termination for convenience, Contractor waives any claim for damages, including for loss of anticipated profits from the Project. The following will constitute full and fair compensation to Contractor, and Contractor will not be entitled to any additional claim or compensation:

(1) *Completed Work.* The value of its Work satisfactorily performed as of the date notice of termination is received, based on Contractor’s schedule of values and unpaid costs for items delivered to the Project site that were fabricated for incorporation in the Work;

(2) *Demobilization.* Demobilization costs specified in the schedule of values, or if demobilization costs were not provided in a schedule of values pursuant to Section 8.1, then based on actual, reasonable, and fully documented demobilization costs; and

(3) *Termination Markup.* Five percent of the total value of the Work performed as of the date of notice of termination, including reasonable, actual, and documented costs to comply with the direction in the notice of termination for convenience, and demobilization costs, which is deemed to cover all overhead and profit to date.

(B) **Disputes.** If Contractor disputes the amount of compensation determined by City pursuant to paragraph (A), above, its sole recourse is to comply with the Claim

procedures in Article 12, by submitting a Claim no later than 30 days following notice from City of total compensation to be paid by City.

13.5 Actions Upon Termination for Default or Convenience. The following provisions apply to any termination under this Article, whether for default or convenience, and whether in whole or in part.

(A) **General.** Upon termination, City may immediately enter upon and take possession of the Project and the Work and all tools, equipment, appliances, materials, and supplies procured or fabricated for the Project. Contractor will transfer title to and deliver all completed Work and all Work in progress to City.

(B) **Submittals.** Unless otherwise specified in the notice of termination, Contractor must immediately submit to City all designs, drawings, as-built drawings, Project records, contracts with vendors and Subcontractors, manufacturer warranties, manuals, and other such submittals or Work-related documents required under the terms of the Contract Documents, including incomplete documents or drafts.

(C) **Close Out Requirements.** Except as otherwise specified in the notice of termination, Contractor must comply with all of the following:

(1) Immediately stop the Work, except for any Work that must be completed pursuant to the notice of termination and comply with City's instructions for cessation of labor and securing the Project and any other Worksite(s).

(2) Comply with City's instructions to protect the completed Work and materials, using best efforts to minimize further costs.

(3) Contractor must not place further orders or enter into new subcontracts for materials, equipment, services or facilities, except as may be necessary to complete any portion of the Work that is not terminated.

(4) As directed in the notice, Contractor must assign to City or cancel existing subcontracts that relate to performance of the terminated Work, subject to any prior rights, if any, of the surety for Contractor's performance bond, and settle all outstanding liabilities and claims, subject to City's approval.

(5) As directed in the notice, Contractor must use its best efforts to sell any materials, supplies, or equipment intended solely for the terminated Work in a manner and at market rate prices acceptable to City.

(D) **Payment Upon Termination.** Upon completion of all termination obligations, as specified herein and in the notice of termination, Contractor will submit its request for Final Payment, including any amounts due following termination pursuant to this Article 13. Payment will be made in accordance with the provisions of Article 8, based on the portion of the Work satisfactorily completed, including the close out requirements, and consistent with the previously submitted schedule of values and unit pricing, including demobilization costs. Adjustments to Final Payment may include deductions for the cost of materials, supplies, or equipment retained by Contractor; payments received for sale of any such materials, supplies, or equipment, less re-stocking fees charged; and as otherwise specified in Section 8.3, Adjustment of Payment Application.

(E) **Continuing Obligations.** Regardless of any Contract termination, Contractor's obligations for portions of the Work already performed will continue and the provisions of the Contract Documents will remain in effect as to any claim, indemnity obligation,

warranties, guarantees, submittals of as-built drawings, instructions, or manuals, record maintenance, or other such rights and obligations arising prior to the termination date.

Article 14 - Miscellaneous Provisions

- 14.1 Assignment of Unfair Business Practice Claims.** Under Public Contract Code § 7103.5, Contractor and its Subcontractors agree to assign to City all rights, title, and interest in and to all causes of action it may have under section 4 of the Clayton Act (15 U.S.C. § 15) or under the Cartwright Act (Chapter 2 (commencing with § 16700) of Part 2 of Division 7 of the Business and Professions Code), arising from purchases of goods, services, or materials pursuant to the Contract or any subcontract. This assignment will be effective at the time City tenders Final Payment to Contractor, without further acknowledgement by the parties.
- 14.2 Provisions Deemed Inserted.** Every provision of law required to be inserted in the Contract Documents is deemed to be inserted, and the Contract Documents will be construed and enforced as though such provision has been included. If it is discovered that through mistake or otherwise that any required provision was not inserted, or not correctly inserted, the Contract Documents will be deemed amended accordingly.
- 14.3 Waiver.** City's waiver of a breach, failure of any condition, or any right or remedy contained in or granted by the provisions of the Contract Documents will not be effective unless it is in writing and signed by City. City's waiver of any breach, failure, right, or remedy will not be deemed a waiver of any other breach, failure, right, or remedy, whether or not similar, nor will any waiver constitute a continuing waiver unless specified in writing by City.
- 14.4 Titles, Headings, and Groupings.** The titles and headings used and the groupings of provisions in the Contract Documents are for convenience only and may not be used in the construction or interpretation of the Contract Documents or relied upon for any other purpose.
- 14.5 Statutory and Regulatory References.** With respect to any amendments to any statutes or regulations referenced in these Contract Documents, the reference is deemed to be the version in effect on the date that bids were due.
- 14.6 Survival.** The provisions that survive termination or expiration of this Contract include Contract Section 11, Notice, and subsections 12.1, 12.2, 12.3, 12.4, 12.5, and 12.6 of Section 12, General Provisions; and the following provisions in these General Conditions: Section 2.2(J), Contractor's Records, Section 2.3(C), Termination, Section 3.7, Ownership, Section 4.2, Indemnity, Article 12, Dispute Resolution, and Section 11.2, Warranty.

END OF GENERAL CONDITIONS

Special Conditions

1. Construction and Demolition Debris Management Plan

A completed construction and demolition (C&D) Debris Management Plan must be submitted using the City's Green Halo on-line application. All debris disposal and recycling from the construction project must be tracked throughout the duration of the project. The contractor must use Green Halo cupertino.wastetracking.com to create their Plan and to submit all construction waste generation tonnage information. No additional compensation will be paid for implementation of the Debris Management Plan and failure to meet all plan requirements may result in work stoppage, fines, and/or backcharges. For additional information, visit www.cupertino.gov/greendev

2. Authorized Work Days and Hours.

2.1 Authorized Work Days. Except as expressly authorized in writing by City, Contractor is limited to performing Work on the Project on the following days of the week, excluding holidays observed by City: Monday to Friday.

2.2 Authorized Work Hours. Except as expressly authorized in writing by City, Contractor is limited to performing Work on the Project between 7:00 a.m. to 5:00 p.m., Monday through Friday (excluding City observed holidays). Work hours within the travel shall be determined by street type and proximity to schools. See Technical provisions. Vehicle travel may be further limited by Cupertino Municipal code. See Truck Traffic Restrictions map included with these specifications. Any request for work outside of these hours must be submitted in writing and approved in advance by the City's Team two working days in advance. Equipment and material may arrive no earlier than 7:00 a.m. to the site.

3. Pre-Construction Conference. City will designate a date and time for a pre-construction conference with Contractor following Contract execution. Project administration procedures and coordination between City and Contractor will be discussed, and Contractor must present City with the following information or documents at the meeting for City's review and acceptance before the Work commences:

- 3.1** Name, 24-hour contact information, and qualifications of the proposed on-site superintendent;
- 3.2** List of all key Project personnel and their complete contact information, including email addresses and telephone numbers during regular hours and after hours;
- 3.3** Staging plans that identify the sequence of the Work, including any phases and alternative sequences or phases, with the goal of minimizing the impacts on residents, businesses and other operations in the Project vicinity;
- 5.4** If required, traffic control plans associated with the staging plans that are signed and stamped by a licensed traffic engineer;
- 3.5** Draft baseline schedule for the Work as required under Section 5.2 of the General Conditions, to be finalized within ten days after City issues the Notice to Proceed;
- 3.6** Breakdown of lump sum bid items, to be used for determining the value of Work completed for future progress payments to Contractor;

- 3.7 Schedule with list of Project submittals that require City review, and list of the proposed material suppliers;
- 3.8 Videotape and photographs recording the conditions throughout the pre-construction Project site, showing the existing improvements and current condition of the curbs, gutters, sidewalks, signs, landscaping, streetlights, structures near the Project such as building faces, canopies, shades and fences, and any other features within the Project area limits;
- 3.9 If requested by City, Contractor's cash flow projections; and
- 3.10 Any other documents specified in the Special Conditions or Notice of Potential Award.

4. Insurance Requirements. The insurance requirements under Section 4.3 of the General Conditions are modified for this Contract, as set forth below. Except as expressly stated below, all other provisions in Section 4.3 are unchanged and remain in full force and effect.

- 4.1 **Builders Risk Insurance Waived.** The builder's risk insurance policy requirement set forth in subsection 4.3(A)(5) of the General Conditions is hereby waived and does not apply to this Contract.

5. Traffic Control Requirements

The Contractor shall submit traffic control plans to the Engineer for approval five (5) working days prior to the pre-construction meeting. Traffic control plans shall conform to the requirements in item number 5.22 below. All cost and expense for traffic control shall be included in the bid prices for various bid items and no special compensation shall be allowed.

5.1 The Contractor shall conduct operations and schedule cleanup so as to cause the least possible obstruction and inconvenience to traffic, pedestrians, cyclists and adjacent property owners. All work areas shall be swept clean at the end of each day's work and at other times when directed by the Engineer. A mobile street sweeper shall be used wherever practical and dust shall be suppressed to the satisfaction of the Engineer.

5.2 The Contractor shall protect open excavations, trenches, and such during construction with fences, covers, and railings as required, together with signs, lights, and other warning devices sufficient to maintain safe pedestrian, bicycle and vehicular traffic to the satisfaction of the Engineer.

5.3 Damage done by the Contractor during the course of the work to adjacent City, public or private property shall be repaired in kind, or as directed by the Engineer, at the Contractor's expense. This includes the repair of traffic loop detectors, striping, signing, curb markings, etc. Loop detectors must be repaired within one week of the damage.

5.4 The Contractor shall remove all forms, debris, and undesirable material from the job site at the end of each work day. After each site has been completed, the Contractor shall restore planting areas and other areas abutting the work to the condition existing at the start of work.

5.5 No stockpiling of materials or parking of equipment during non-working hours will be allowed on City property, i.e., streets, alleys, parking lots, sidewalks, etc.

5.6 The Contractor's employees are subject to all parking regulations in effect in the City of Cupertino.

5.7 The Engineer shall have the right to limit the amount of asphalt digouts which may be opened or partly opened at any time. No more than 300 feet of asphalt digouts shall be left open at any one time.

5.8 All open trench and excavations must be backfilled and paved with temporary asphalt concrete or non-skid steel plated at the end of each work day. The Contractor shall place 18 inches cold cutback around the edges of steel plates to eliminate the vertical edges.

5.9 Spillage resulting from hauling operations along or across any public traveled way shall be removed immediately by the Contractor at his expense.

5.10 The Contractor shall place barricades 50 feet on center at the gutter joints and provide one working flasher for each barricade and shall insure that each flasher is maintained in working condition while in use. The Contractor shall not remove the barricades in the street at any given location until the asphalt concrete patching adjacent to the gutter and/or gutter overlay has been done and the hazard to bicyclists and motorists no longer exist.

5.11 Contractor shall maintain access to all driveways except when actually doing construction within the driveway boundaries, at which time partial access will be maintained unless alternate arrangements can be made with the property owners or tenants in advance. If the driveway to any garage or parking area is to be closed for construction work, prior written approval must be obtained from the property owners and the Engineer. Notice shall be posted by the Contractor 72 hours in advance stating the approximate time the driveway will be closed and reopened.

5.12 City of Cupertino Truck Routes for all hauling shall be used, as described in Section 10 of the Special Provisions.

5.13 Contractor shall obtain a Transportation permit from the Public Works Department for any vehicle which exceeds weight or dimensions prescribed in the California Vehicle Code.

5.14 The Contractor shall provide a certified professional traffic control crew that is independent from the construction activity. This traffic control crew shall be responsible to the Contractor for implementing the traffic control measures detailed in this Contract. The crew is subject to the approval of the Engineer.

5.15 The Contractor shall supply, place, and maintain all necessary traffic control devices during construction in accordance with the applicable requirements of the City of Cupertino, the California Manual of Uniform Traffic Control Devices, and the traffic control plans approved by the City.

5.16 All traffic control devices shall conform to Section 12 of the Caltrans Standard Specifications. They are to be in good condition and sufficiently clean so as to be easily visible to traffic. All signs shall be placed in positions where they convey their message most effectively or as shown on the approved traffic control plan.

5.17 Type II and III barricades with working flashers shall be used. At least one working flashing light must be installed on each barricade for night work. Flashing lights must be maintained in good working order throughout the duration of the work. Crosswalk closing barricades shall be Type II with a 6" orange border at the base.

5.18 Signs to be used for traffic control shall conform to the requirements of the California Manual of Uniform Traffic Control Devices. Signs that are attached to existing poles shall not cause any damage to the poles when they are attached or removed. All of the hardware that is used when attaching signs to existing poles shall be completely removed from the poles when the signs are removed. If a construction sign is required in an area where it cannot be attached to an existing pole, it shall be attached to a 4" x 4" wooden pole. The distance from the ground surface to the bottom of the sign shall be seven (7) feet.

5.19 A flag-type high level warning device with three or more flags shall be used for each direction of traffic affected, generally placed within the taper area.

5.20 Flashing arrow boards shall be Type A or Type II as described in Section 6F.56 of the California Manual of Uniform Traffic Control Devices. Flashing arrow boards are required for lane shifts and reductions and may be required for nighttime work.

5.21 Dated "No Parking Tow Away" signs shall be posted a minimum of 72 hours in advance of all work requiring that cars not be parked on the street. Date and time of work shall be written on signs in two-inch-high letters with a ¼-inch felt black marker. Signs shall be posted 50 feet on center and removed immediately after the work is completed. The Contractor must notify the Project Inspector with locations of posting to verify seven-two (72) hour notice.

5.22 Traffic Control Plans. A traffic control plan consistent with the following generally applicable conditions must be approved by the Public Works Department 30 days prior work. The Contractor shall supply, place, and maintain all necessary traffic control devices in accordance with the California Manual of Uniform Traffic Control Devices and the following conditions:

- Traffic control plans will include a schedule of construction showing each phase of work and the anticipated method of handling traffic for each phase. Traffic control plans will include a scaled drawing of the street, lane configuration, parking, sidewalk, work area, and the location of signs and cones, etc., to warn, direct, and guide the traffic. The traffic control plan shall reflect actual (not typical) intersection layout and indicate islands, medians, lane lines, bike lanes, nearby driveways, and note all pavement and lane widths. All traffic control plans shall be professionally prepared.
- In general, Contractor shall maintain all vehicular, pedestrian, and bike movements. No total closure of any arterial or collector street will be permitted. City may allow closure of local residential streets but Contractor shall always maintain local and emergency access.
- The Contractor shall maintain one lane of traffic in each direction at all times on all streets. The clear width of the lane shall be a minimum of 10 feet.
- A minimum four feet clear sidewalk shall be maintained unless the work makes closure unavoidable, in which case the sidewalk may be closed while working, subject to the approval of the Engineer. However, an alternate pedestrian facility must be provided for the duration of the closure. At intersections, work will be permitted at one corner at a time so pedestrian movements can be maintained through the intersection.

5.23 Work shall not restrict visibility of any traffic control device.

5.24 No work will be permitted within 1500 feet of school grounds until after 9:30 a.m. on school days. Other special restrictions may be required at heavily used school crossings or school commute routes beyond 1500 feet from the school grounds as deemed necessary for student safety by the Engineer.

5.25 No closure of lanes on arterial and collector streets will be permitted between the hours of 7 and 9 a.m. and 3:30 and 7 p. m.

5.26 If work will impact transit stops or transit routes, Contractor shall be required to contact Santa Clara Valley Transportation Authority or other affected transit companies to address relocation of facilities or rerouting of buses prior to submitting traffic control plan. Traffic control plan should indicate what actions are being taken with regard to transit services.

5.27 Any work within 150 feet of any signalized intersection should be coordinated with the Traffic Signal Technician at (408) 777-1366.

5.28 The Contractor shall be required at Contractor's expense to hire Santa Clara County Sheriff's officers to direct traffic when working at signalized intersections, especially when (1) equipment is intermittently blocking or crossing a traffic lane; (2) only one lane of traffic is available for two directions of traffic; (3) one lane of traffic is available in each direction, but the left turning traffic is also using the through lane; and (4) at multiple lane signalized intersections. A minimum of two officers per intersection shall be required. Additional officers may be required by the engineer.

5.29 All signs and other warning devices shall be provided by the Contractor and shall become his property after completion of the Contract. The cost of providing, installing and maintaining signs, lights, caution tape, delineators, flares, barricades and other facilities as directed by the Engineer for the convenience and direction of public traffic shall be included in the prices paid for the various items of work involved in the project.

5.30 The above requirements are a minimum and do not limit the Contractor's responsibility of doing all that is practical and necessary to ensure the safety of workers, pedestrians, bicyclists, and motorists. The Contractor shall conform to the above traffic control requirements which are generally applicable to most common situations. Based on the nature of a job, additional conditions or exceptions to the above conditions may be necessary.

- 6. SUBMITTALS FOR QUALITY ASSURANCE.** In the Technical Specifications, the City may specify quality assurance requirements, including qualifications for special skills and experience required of the Contractor. For any specified skill, the Contractor may use a subcontractor that specializes in the work and meets the performance requirements or the Contractor may self-perform the work, subject to demonstrating the necessary skill, experience, and/or certifications to perform the work.

The Contractor will submit verification that the materials and labor skills meet the specified requirements prior to implementing the specific work through the submittal process.

- 7. NOTIFICATION TO ABUTTING PROPERTIES** The contractor shall provide advanced notification to residents, businesses and schools a minimum of two times prior to construction as follows.

10.1 Advanced Notification Doorhangers

The contractor shall submit a sample door hanger to the City of Cupertino for review and approval. At a minimum, the doorhanger shall include the type of work to be completed, limits of work, hours of work, parking and access restrictions during construction and contractor contact information. The first door hanger shall be distributed to residents, businesses and schools along effected streets 5 working days prior to construction. The second shall be distributed 48 hours prior to commencement of work. Notification will be necessary prior to each phase of work including crack seal, slurry seal and fog seal. Contractor must also notify schools when work occurs on a route to school or within 500 ft radius of school. If construction operations are delayed for any reason beyond the duration stipulated in the notices, the Contractor shall re-issue written notices that explain the delay and provide a revised schedule. Payment for compliance with this section shall be deemed included in the various other items of work, and no additional compensation will be allowed therefore.

SAMPLE NOTICE:

NOTICE TO RESIDENTS / BUSINESS OWNERS

Date: [MONTH] [DAY], [YEAR]

Subject: [NAME OF PROJECT] – [Seven Day OR Two Day] Notice

This notice is to inform you that the City of Cupertino, Department of Public Works, has contracted with [CONTRACTOR NAME] to [SCOPE OF WORK] along [STREET NAME] from [ADJACENT CROSS STREET] to [ADJACENT CROSS STREET]. This [SCOPE OF WORK] will mainly occur on [WEEKDAYS, SEE “SCHEDULE OF WORKING DAYS/HOURS”] from [START TIME] to [END TIME] and is scheduled to start in your area **APPROXIMATELY seven days from the date of this notice and will continue from [START DATE] until [END DATE]**. Please be aware that there may be construction activities that cause traffic delays. [CONTRACTOR NAME] will make every effort to maintain normal traffic access and minimize disruption in your neighborhood. No Parking / Tow-Away signs will be posted in affected areas two working days in advance of enforcement. Access to driveways will be maintained at ALL times during the construction. Prior to activities in your immediate area, you will be sent a notification **TWO WORKING DAYS** before work begins. [CONTRACTOR NAME] and the City of Cupertino, Department of Public Works, apologize for any inconvenience due to these activities. If you have any questions or need assistance as these activities progress, please call the number(s) listed below: [CONTRACTOR NAME]

7.2 Night Work Notification

The Contractor shall distribute advanced notification of night work to residents and businesses located within 750’ of the limits of night work. The notice shall include dates and times of work to be completed. The Contractor shall submit a draft notification for review and approval prior to distribution. Notices shall be delivered a minimum of one week prior to work.

7.3 Towing Procedure

Cupertino Municipal Code Section 11.24.200 D authorizes the tow away of vehicle parked on a public street where construction or street repair work is scheduled to occur. The Contractor performing the scheduled work is responsible for erecting the required signs giving notice that such vehicles may be towed away if left on the street during the time that the work is scheduled to be performed. The signs shall be erected at least 72 hrs. prior to the scheduled start of work. The specific dates and times of work shall be written in two-inch-high letters with a ¼-inch felt black marker. Signs shall be posted on Type II barricades, 50 feet on center and removed immediately after the work is complete. The Contractor shall update signs as necessary. The Contractor must notify the Project Inspector with locations of posting, to verify forty-eight (48) hour notice. All costs for notification and posting of signs shall be included in the various items of work and no special compensation will be allowed.

END OF SPECIAL CONDITIONS

TECHNICAL SPECIFICATIONS

1. TRAFFIC CONTROL (Bid Item Number 1)

a. Item Requirement

Contractor shall furnish all necessary supervision, labor, materials, construction tools and equipment, supplies to complete traffic control at each location during the times immediately prior, during and after work.

b. Scope

Construction area signs shall be furnished, installed, and removed when no longer required. The Contractor's attention is directed to Section 7-1.08, "Public Convenience", Section 7-1.09, "Public Safety", and Section 12, "Construction Area Traffic Control Devices", of the Caltrans Standard Specifications and Section 00820 Traffic Control Requirements of these specifications.

All traffic control devices shall conform to the latest "Manual of Traffic Control for Construction and Maintenance Work Zones" issued by Caltrans.

(a) Advance construction warning signs shall be placed on all streets leading into the construction area before any construction is started.

(b) Speed limit advisories may be placed along the main traffic lanes.

(c) When detours or changes in traffic lanes are required, directional signs shall be placed at each end and along the roads.

(d) Warning signs, caution signs, and end construction signs, shall be placed at each end of the work and along the route when conditions warrant their use.

The Contractor shall submit a detailed traffic control plan for all work that requires lane closures at least 5 days prior to the lane closure. No lane closure will be allowed without prior approved traffic control plan specific to that location. Traffic control shall be planned for each individual lane closure with detail layouts of all signage locations.

The Contractor is responsible for proper placement and maintenance of all signs and barricades. Any additional signs, barricades, lights, etc., that may be required by the Engineer to ensure public safety shall be installed and maintained by the Contractor.

Note: Traffic Controls – Qualified Individual: Traffic controls through the construction zone shall be designed and maintained by a designated individual qualified in this responsibility. The qualified traffic control individual shall have no other responsibilities other than traffic control.

The name(s) of the qualified traffic control individual shall be submitted and approved prior to beginning work.

If required in the traffic control plan, and always during one way traffic control, flagmen will be required to direct traffic during construction. The number and location of flagmen shall be sufficient to allow safe control and passage of traffic through the work zone. During the paving of intersections, two flagmen shall be posted at each intersection for the entire duration of work and until the intersection is open to normal traffic operations.

If a cross street needs to be temporarily closed when work is in progress through the intersection and the anticipated delay is more than five minutes, a detour sign shall be installed on the cross street and shall include the installation of advance signing displaying the anticipated delay time. The signing shall be reviewed by the Traffic Engineer.

When required by the Engineer, the Contractor shall supply **two (2)** message boards per arterial / collector street, to be placed at designated locations for advanced warning of construction dates and times. The message shall be preapproved by the engineer prior to programming. Message boards shall be set up at least two weeks prior to work.

The term "Construction Area Signs" shall include all temporary signs required for the direction of public traffic through or around the work during construction. Such signs are shown in or referred to in the current MANUAL OF TRAFFIC CONTROLS – Warning signs, Lights and Devices for Use in Performance of Work Upon Highways, published by the State of California, Department of Transportation, hereinafter referred to as MANUAL OF TRAFFIC CONTROLS.

Restrictions on Closure of Traffic Lanes

The streets shall be open for use by public traffic on Saturday, Sunday, and any day designated by the City as a legal holiday or any day preceding a designated legal holiday; before 8 a.m. and after 5 p.m., Monday thru Friday or as further restricted by Attachment A, and when construction operations are not actively in progress on working days. During daily construction operations, there may be certain peak traffic hours that would require the Contractor to alter the construction schedule in order to minimize the impact of the work on the public's convenience.

The following provisions shall apply on the listed street segments:

<u>Street</u>	<u>Special Traffic Control Provision</u>
<u>Arterials:</u>	One lane in each direction of traffic shall be maintained at all times. The roadway shall be open for two-way traffic at all

times.

Collectors:

N. Portal Ave,
Lazaneo Dr, Mann Dr,
Vista Dr

On four lane streets, one lane in each direction shall be maintained at all times. On two lane streets, flagmen shall be used to maintain traffic flow and lane closure hours shall be limited to 9:30 AM to 2:00 PM. Contractor shall coordinate with SCC Fire prior to work on Vista Dr.

Streets Near Schools

Lazaneo Dr, Vista Dr,
Pacifica Dr, Farallone
Dr, La Roda Dr, Hyde
Ave, Willowgrove, Ln,
Brookgrove Ln,
Ferngrove Ln, N Portal
Ave, Auburn Dr,
Auburn Ct

Traffic may be limited to only local traffic during the period between 9:30 a.m. and 2:00 p.m. Work may be required on weekends to minimize traffic impacts. Flagman shall be used to control traffic. **Streets immediately adjacent to schools shall be sealed when school is out of session.**

Residential:

Traffic may be limited to only local traffic during the period between 8 a.m. and 4:30 p.m. Construction vehicle access may be further limited (see truck traffic restrictions map)

Refer to “Attachment A” – Work Hour Restrictions for authorized lane closure hours on a street by street basis.

Attention is directed to Sections 7-1.08, “Public Convenience,” 7-1.09, “Public Safety,” and 12, “Construction Area Traffic Control Devices,” of the State Standards and to the Section entitled “Public Safety” and flagging for traffic control systems elsewhere in these technical specifications. Nothing in these technical specifications shall be construed as relieving the Contractor from his responsibility as provided in said Section 7-1.09.

Lane closures shall conform to the provisions in the section of these special provisions entitled “Traffic Control for Lane Closure.”

Personal vehicles of the Contractor’s employees shall not be parked on the traveled way or shoulders, including any section closed to public traffic.

The Contractor shall notify local authorities of his intent to begin work at least 7 calendar days before work is begun. The Contractor shall cooperate with local authorities relative to handling traffic through the area and shall make his own arrangements relative to keeping the working area clear of parked vehicles.

Whenever vehicles or equipment are parked on the shoulder within 6 feet of a traffic lane, the shoulder area shall be closed with fluorescent traffic cones or portable delineators placed on a taper in advance of the parked

vehicles or equipment and along the edge of the pavement at 25-foot intervals to a point not less than 25 feet past the last vehicle or piece of equipment. A minimum of 9 cones or portable delineators shall be used for the taper. A C23 (Road Work Ahead) or C24 (Shoulder Work Ahead) sign shall be mounted on a telescoping flag tree with flags. The flag tree shall be placed where directed by Engineer. Bike Lane Closed Ahead and Share the Road signs shall be placed where applicable.

In order to minimize the impact on local merchants, and residents, driveways shall not be blocked for any long periods of time. The Contractor shall maintain access to all driveways before and after road material is placed. The Contractor shall limit the time between the prep time placing and curing time of the asphalt material and cleanup so that vehicles may return the roadway to use.

The full width of the traveled way shall be open for use by public traffic on weekends designated legal holidays, and when construction operations are not actively in progress unless approved otherwise.

Minor deviations from the requirements of this section concerning hours of work which do not significantly change the cost of the work may be permitted upon the written request of the Contractor if in the opinions of the Engineer public traffic will be better served and the work expedited. Such deviations shall not be adopted until the Engineer has indicated his written approval. All other modifications will be made by contract change orders.

A traffic control system shall consist of closing traffic lanes in accordance with the provisions of Section 12, "Construction Area Traffic Control Devices," of the State Standards, the provisions under "Maintaining Traffic" elsewhere in these technical specifications.

The provisions in this section will not relieve the Contractor from his responsibility to provide such additional devices or take such measures as may be necessary to comply with the provisions in Section 7-1.09, "Public Safety," of the State Standards.

If any component in the traffic control system is damaged, displaced, or ceases to operate or function as specified, from any cause, during the progress of work, the Contractor shall immediately repair said component to its original condition or replace said component and shall restore the component to its original location.

Lane closures are made for work periods only, at the end of each work period, all components of the traffic control system, except portable delineators placed along the traveled way, shall be removed from the traveled way, shoulder and auxiliary lanes.

c. Measurement & Payment

The contract lump sum price paid for Traffic Control shall include full compensation for furnishing all labor including flagging costs, materials (including signs), tools, equipment and incidentals, and for doing all the work involved in placing, removing, storing, maintaining, moving to new locations, replacing and disposing of the components of the traffic control system and preparing required traffic control plans, as specified in the State Standards and these technical specifications, and as directed by the Engineer.

2. CRACK SEALING (Bid Item Number 2)

a. Item Requirement

This work shall consist of removing vegetation, embedded sand and dirt and all other debris and incompressible materials, evaporating moisture from cracks and joints in the asphalt concrete pavement, and cleaning and filling the cracks with rubber asphalt joint seal as specified in these special provisions, and as directed by the Engineer.

b. Scope

MATERIALS

The crack sealant shall be a mixture of paving asphalt and ground rubber and shall conform to ASTM D6690, Type II.

CONSTRUCTION

All cracks 3/32 of an inch wide or wider shall be sealed. Immediately prior to applying the sealant, the cracks shall be cleaned. Removal of vegetation and all incompressible materials from cracks and joints shall be by means of hot compressed air lance. (Other methods such as routing with compressed air cleaning may be substituted at engineer's specification. Under ANY circumstances compressed air used for cleaning MUST be oil free.) Before sealing, the crack surfaces must be made clean, dust free, and dry. The preferred way to remove the moisture is with the use of the hot compressed air lance. The temperature will be at least 2000 degrees F. The lance shall be not more than 50 feet ahead of the sealing unit, as they progress down the pavement, so that the crack area does not have time to cool or take up new moisture from below.

Crack seal materials shall be placed in conformance with the manufacturer's recommendations. Crack seal materials shall not be placed when the surface temperature is below 50 degrees Fahrenheit.

The finished crack seal shall be bonded to the crack such that there is no separation or opening between the sealant and the crack edge and there shall be no cracks, separation or other opening in the sealant.

The Contractor shall remove crack seal material that is not placed within the conformance of these provisions, clean cracks as specified herein and then reseal the cracks at his expense.

c. Measurement & Payment

The Contract Price shall be paid by the lineal foot for rubberized asphalt crack seal and shall include full compensation for furnishing all labor, materials, tools, equipment, traffic control and incidentals, and for doing all the work involved in constructing rubberized asphalt sealed cracks, complete in place.

3. FOG SEAL (Bid Item Number 3)

a. Item Requirement

The Work under this Section includes providing all labor, material, tools and equipment necessary to apply a polymer modified asphaltic emulsion rejuvenating seal to streets listed in exhibit A.

b. Scope

NOTIFICATION

Contractor shall distribute advanced warning door hangers to all residents and businesses along effected streets and least 48 hours but no more than 96 hours prior to work. At minimum, the door hangers shall include the type of work to be completed, location of work. Scheduled dates of work, access restrictions during construction and contractor contact information.

MATERIALS

The emulsion used shall be polymer modified and shall comply with Section 94 of Caltrans Standard Specifications.

CONSTRUCTION

The Contractor shall be responsible for preparation of the pavement to receive fog seal coat as required under Section 37 of the Standard Specifications. Immediately prior to the application of fog seal coat, the streets shall be cleaned by sweeping with self-propelled vacuum or regenerative air sweepers with water spray bars to reduce dust. Sidewinder sweepers or brooms that wind row material and do not remove it shall not be used. Prior to fog seal application, pavement surfaces shall be cleaned of all oil, debris, grease spots and weeds. Before applying fog seal coat, contractor shall cover manholes, valve boxes, monument boxes, other exposed facilities and all existing pavement markers, markings, legends and speed bumps within the area of application with plastic or oil resistant construction paper secured in place. All traces of plastic or oil resistant construction paper shall be removed as quickly as possible following application of fog seal. Contractor shall replace or clean

at his or her own expense any damaged or oil stained items within project limits.

The emulsion shall be applied with a distributor truck to the pavement surface at a rate of .07 gal / S.Y - .10 gal/ S.Y. The final rate of application will be jointly determined by the engineer, contractor and the vendor.

The asphalt distributor for application of the emulsion shall have a full circulation spray bar that is adjustable to at least sixteen (16) feet wide and capable of heating and circulating the emulsion simultaneously. It must have computerized rate control for adjusting and controlling the application from the cab by .01 gallons per square yard increments. The distributor shall also be equipped with a volume measuring devise and a thermometer for measuring the emulsion temperature in the tank.

The fog seal shall not be placed if either the pavement temperature or the air temperature is below 50 degrees F and falling, but may be applied when both the air and pavement temperature is 50 degrees F or above and rising. The fog seal coat shall not be placed if rain has occurred within the past 24 hours. The weather forecasts should be for highs near sixty degrees Fahrenheit and no rain forecast for the next twenty-four hours after the fog seal has been applied. The fog seal should not be placed if the high temperatures for the day exceed 95 degrees unless approved by the Engineer.

The distributor driver must be experienced at applying rejuvenation seals. Precautions must be taken to prevent any material from entering the storm drain system. See Section 7.20 of the General Conditions for Storm Water Pollution Prevention requirements.

c. Measurement and Payment

The contract square yard price paid shall include full compensation for furnishing all labor, materials, tools, equipment and incidentals, notifying residents and business, and for doing all the work necessary to prepare the surface, mix and apply fog seal and protecting the seal in place until it has set. No additional compensation will be made therefor. traffic control for fog seal shall be paid under the Traffic Control bid item.

3. SLURRY SEAL (Bid Item Number 4)

a. Item Requirement

The work shall consist of furnishing all necessary labor, materials and equipment for the transporting, mixing of asphaltic emulsion, aggregate and water and spreading the mixture of pavement areas to conform to the Provisions of Section 37-3, "Slurry Seal and Micro-surfacing," of the Caltrans 2018 Standard Specifications, Revised Standard Specifications, and these Special Provisions.

Asphalt Emulsion

Asphaltic Emulsion used for slurry seal shall be designated as grade PMCQS-1h or equal. Solid polymers shall be adequately blended into the asphalt prior to emulsification. If a liquid latex such as neoprene or similar is used, the latex shall be “co-milled” into the emulsion through the water phase during manufacturing.

Each load of polymer modified asphaltic emulsion shall have a certificate from the asphalt emulsion manufacturer guaranteeing that either asphalt blending or “co-milling” processes were used. The certificate shall also state the percentage of the solid rubber polymer added by weight of the asphalt as well as the composition of the polymer. The addition of latex to the emulsion after emulsion manufacturing is prohibited.

The polymer modified asphalt emulsion shall conform to the following specifications:

Tests on Emulsion			
Test	Test Method	Requirement	
		Minimum	Maximum
Viscosity SSF, @ 77°F, seconds	AASHTO T59	15	90
Sieve Test, %	AASHTO T539	---	0.30
Storage Stability Test, 1 day %	AASHTO T59	---	1.0
Residue by Evaporation, %	CTM 331	57	---
Particle Charge	AASHTO T59	Positive	

Tests on Residue			
Test	Typical	Requirement	
		Minimum	Maximum
Penetration, 77°F	AASHTO T49	40	90
Ductility, 77°F, mm	AASHTO T51	400	---
Polymer Content, % See Section 94-1.01C of the Standard Specifications for Sampling Requirements	CTM 401	2.5%	---
OR			
Torsional Recovery, %	CTM 332	18	---

A certificate of Compliance shall be furnished to the Engineer in accordance with Section 6-3.05E, “Certificates of Compliance,” of the Standard Specifications and these Special Provisions. The Certificate of Compliance shall include all information stipulated in Section 94, “Asphaltic Emulsions,” of the Standard Specifications. Additional information relevant to the specifications shall be furnished if requested by the Engineer. Samples will be obtained in accordance with ASTM Method D140 or such other methods as are approved by the Engineer.

Aggregate

Aggregate for the slurry seal shall comply in all respects to requirements in Section 37-3, "Slurry Seal and Micro-surfacing," of the Standard Specifications for a Type II slurry seal except for the following:

Aggregate shall consist of sound, durable, crushed stone or crushed gravel. If approved by the Engineer, mineral filler will be allowed. Aggregates shall be 100% crushed with no rounded particles, volcanic in origin, and black in color. The use of gray or light-colored aggregate will not be allowed. The percentage composition by weight of the aggregate shall conform to the following grading:

Percentage Passing	
Sieve sizes	Type II
3/8" (9.5 – mm)	100
No. 4 (4.75 – mm)	90 - 100
No. 8 (2.36 – mm)	65 - 90
No. 16 (1.18 – mm)	40 - 70
No. 30 (600 – um)	25 - 50
No. 200 (75 – um)	5 - 15
Theoretical asphalt content, % based on dry aggregate	7.5 - 13.5
Approximate application rate (Pounds/Square Yard)	14-18

The aggregate shall also conform to the following quality requirements:

Test	Method of Test	Requirement
Sand Equivalent	California Method 217	60 min.
Durability Index	California Method 229	55 min.

When the results of both the aggregate grading and the Sand Equivalent test do not conform to the requirement specified, both payments to the Town shall apply. The Town may deduct these amounts from any monies due, or that may become due the Contractor under the contract. No single aggregate grading or Sand Equivalent test shall represent more than 300 tons or one-day's production whichever is smaller.

The Contractor, in accordance with Section 6-3.05E, "Certificates of Compliance," of the Standard Specifications, will furnish a Certificate of Compliance for aggregates used in the slurry seal. The Certificate of Compliance shall include results of laboratory tests indicating the average gradation, minimum sand equivalent and maximum film stripping and durability index, all in accordance with Section 37-2.02, "Materials," of the Standard Specifications.

Mineral Filler

Mineral filler shall be either Portland Cement, hydrated lime, limestone dust, fly ash or other approved filler meeting the requirements of ASTM D242 and shall be used if required by the mix design. The mineral filler shall be considered as part of the aggregate in calculations regarding slurry seal asphalt content.

Additives

Additives may be used to accelerate or retard the mixing and setting characteristics of the slurry seal or improve the resulting finished surface. The use of additives in the slurry mix (or individual materials) shall be made initially in quantities predetermined by the mix design with field adjustments if required. If the use of additives during application requires a greater than + or – 1.0% deviation from the recommendations of the mix design, a new mix design will be performed to verify system performance at higher or lower additive levels.

Mix Design

At least seven (7) working days before slurry seal placement commences, the Contractor shall submit to the Engineer for approval a laboratory report of tests and proposed mix design covering the specific materials to be used on the project. The percentage of asphalt emulsion proposed in the mix design shall be within the percentage range specified in Section 37-3.03B, “Proportioning,” of the Standard Specifications.

The tests and mix design shall be performed by a laboratory capable of performing the applicable International Slurry Seal Association (ISSA) tests. The proposed slurry seal mixture shall conform to the requirements specified when tested in accordance with the following tests:

Test	Description	Spec
ISSA TB 106	Slurry Seal Consistency, mm	30 maximum
ISSA TB-139	Wet Cohesion (using project source aggregate, asphalt emulsion and set-control agents, if used) 30 minutes min 60 minutes min	12kg-cm minimum 20kg-cm minimum
ISSA TB-109	Excess Asphalt By LWT Sand Adhesion	50 g/ft ² maximum (538 g/m ² maximum)
ISSA TB-114	Wet Stripping	Pass
ISSA TB 115	Compatibility	Pass
ISSA TB-100	Wet Track Abrasion Loss, one-hour soak (minimum asphalt content)	75 g/ft ² maximum (807 g/m ² maximum)
ISSA TB-113	Mix Time (Mixing test and set time test shall be done at the highest temperature expected during construction)	Controllable to 180 sec. minimum

The laboratory report shall be signed by the laboratory that performed the tests and mix design and shall show the results of the tests on individual

materials, comparing the test results to those required by the specifications. The report shall clearly show the proportions of aggregate, filler (as determined from the tests, minimum and maximum), water (minimum and maximum), asphalt solids content based on the dry weight of aggregate and set-control agent usage. The laboratory shall also report the quantitative effects of moisture content on the unit weight of the aggregate (bulking effect). Previous laboratory reports covering the same materials may be accepted provided they are made during the same calendar year.

The Engineer shall approve the mix design and all slurry seal materials and methods prior to use. The job mix design shall conform to the specification limits and be suitable for the traffic climate conditions, curing conditions and final use. This will include recommended application rate of slurry to suit the job conditions. Any changes in the proportions will be made only when approved by the Engineer.

Proportioning

Proportioning shall conform to the provisions in Section 37-3.03B, "Proportioning," of the Standard Specifications and these Special Provisions.

The completed mixture, after addition of water and any set-control agent used, shall be such that the slurry seal mixture has proper workability and (a) will permit uncontrolled traffic on the slurry seal within two (2) hours after placement without the occurrence of tracking, bleeding, raveling, separation or other distresses, and (b) prevent development of bleeding, raveling, separation or other distress within fifteen (15) days after placing the slurry seal.

Mixing and Spreading Equipment

Mixing and spreading equipment shall conform to the provisions in Section 37-3.03C, "Mixing and Spreading Equipment," of the Standard Specifications and these Special Provisions.

A minimum of two 7-cubic yard capacity or larger slurry machines shall be on the job and in good operating condition at all times. Machines must be able to negotiate all turns next to the curbs in cul-de-sacs, on initial pass in one continuous pass.

Preparation of Surface

Before the polymer modified slurry seal is applied, the pavement surface shall be swept free of all debris and loose debris using power sweepers, cracks shall be filled, and digouts completed. The Contractor shall remove all pavement markings, weeds and plant materials in all the street sections that will receive slurry seal surfacing. Removal of weeds and plant materials shall be done using a chemical weed killer (per manufacturer's recommendations) as approved by the Engineer, and all these areas shall be thoroughly cleaned using compressors or other means acceptable to the Engineer. During the striping removal process, large amounts of grinding debris (thermoplastic and asphalt) shall be removed by hand prior to use of a power broom.

All existing/temporary pavement markers, paint and thermoplastic shall be removed and disposed of by the Contractor. Said removal shall not occur sooner than two days prior to the slurry sealing is performed.

Manholes, valves, survey monuments, or miscellaneous frames and covers shall not receive a seal coat. These shall be covered and protected prior to application of slurry. Any frame or cover seal coated shall be cleaned to the satisfaction of the Engineer and the cost for the cleaning shall be borne by the Contractor.

Placing

Placing shall conform to the provisions in Section 37-3.03D, "Placing," of the Standard Specifications and these Special Provisions. The Contractor shall place slurry seal no later than 2 pm onto any street surface.

No application of slurry mixture shall be permitted when the temperature of the pavement to be surfaced is below 50° F or when the air temperature is below 60°F in the shade or when, in the opinion of the Engineer, road conditions, road temperatures, imminence of rain, wetness or dampness are not conducive to successful results.

The slurry mixture shall be uniformly spread by means of a controlled spreader box conforming to the requirements of Section 37-3.03C, "Mixing and Spreading Equipment," of the Standard Specifications.

If required by the Engineer, the slurry machine shall be inspected and calibrated on a 300-foot test section. The calibration shall establish the settings required to obtain the application rate for the slurry and correct proportions of ingredients in accordance with these Special Provisions.

All surfaces to be slurry sealed shall be lightly dampened with a fog spray of water. The slurry machine shall move forward at such a speed that the fluid slurry mixture will penetrate and substantially fill all available voids. The slurry box squeegees, rubber belting, or similar material, shall be flexible enough to wipe the slurry uniformly over the surface of the roadway without gouging, scouring or abrading the existing surface or chips.

The slurry seal mixture shall be spread at a rate between 12-20 lbs./sq. yd. The exact rate will be determined in the field by the Engineer.

Areas which cannot be reached with the slurry seal machine shall be surfaced using hand squeegees to provide complete and uniform coverage. Care shall be taken to leave no unsightly appearance from the handwork. All handwork shall achieve the same type of finish as applied by the spreader box. All incidental handwork such as surfacing of driveway aprons and returns shall be done concurrently with the surfacing of the street proper.

The joint between the edge of pavement and the concrete gutter shall be sealed/filled with slurry seal and not overlap into the gutter pan. Any application spillage beyond this joint shall be removed or cleaned up by the

Contractor to the satisfaction of the Engineer. Gutter spills and any tracking of slurry seal onto concrete improvements shall be cleaned immediately. The edges of the limits of the slurry seal application of both sides of the street shall be maintained in a neat and uniform line. Felt paper shall be placed to ensure neat line at curb returns. Speed bumps shall be covered and protected from slurry application and oil tracking.

All lines of termination of slurry sealing shall be neat and straight. The Contractor shall use building paper or an approved equal header materials at all limits of work. Longitudinal joints shall be at the crown of the street or at the edge of the traveled lanes. No excessive buildup or unsightly appearance shall be permitted on longitudinal and transverse joints.

Care will be taken to avoid leaving ridges at the lap joints between adjoining passes. Wherever possible, joints will coincide with lane lines or in the center of the lane. In no case will ridges be allowed in the normal wheel track of vehicles. The forward speed of the slurry spreader shall be adjusted to eliminate corrugations or surface irregularities in the slurry coat, which are caused by excessive speed.

No lumping, balling, or unmixed aggregate shall be permitted. No segregation of the emulsion and fines from the coarse aggregate shall be permitted. If coarse aggregate settles to the bottom of the mix, the slurry mix shall be removed from the pavement. No excessive breaking of emulsion shall be allowed in the spreader box. No streaks caused by oversize aggregates will be left on the finished pavement, and ridges, washboarding in the finished product shall not be allowed.

Weight tags shall be furnished to the Engineer for all materials delivered to the site including aggregates, emulsified asphalt for slurry and retardant.

The Contractor shall immediately remove any excess slurry from the gutters. The Contractor shall not continue to the next street until all excess slurry is removed as determined by the Engineer. No extension of time will be granted due to delay caused by non-compliance with this provision.

The Contractor shall furnish and maintain in good operating condition all tools and equipment necessary to do the work with a minimum of inconvenience to the public and shall employ sufficient personnel to operate all equipment efficiently and skillfully.

The Contractor shall refrain from using fuel or solvents of any kind for cleaning tools and equipment in such a manner as to permit spillage of diesel fuel or solvent on the pavement, curbs, gutters, parkways or other adjoining areas.

Final Sweeping – A minimum of three (3) self propelled power brooms shall be used that are capable of cleaning the existing pavement and removing loose screenings debris. Gutter brooms or steel-tined brooms shall not be used. Sweeping shall be completed prior to allowing uncontrolled traffic on the road surface. Three (3) additional sweepings shall be performed one day, two days, and either four or five days after placement of slurry seal.

Measurement and Payment: "Slurry Seal" shall be paid for at the contract price per square yard and shall be full compensation for furnishing all labor, materials, tools, equipment, and incidentals for doing all the work involved. Traffic control for Slurry seal shall be paid under the Traffic Control bid item.

5. ASPHALT STRIPING, MESSAGES & MARKERS (Bid Items 5-22)

a. Item Requirement

The Contractor shall furnish and apply traffic stripes, characters, arrows, pavement markers, and other delineations and markings. These shall be reapplied in the original pattern on all roads except as directed by the Traffic Engineer. Contractor shall install traffic striping and markers in accordance with Sections 84 and 85, 'Traffic Stripes and Pavement Markings' and 'Pavement Markers', the most recent version of the California MUTCD, and Caltrans Standard Details A20A through A24F, latest edition. Contractor is required to document existing striping and message types, complete with dimensions, for each street receiving slurry seal treatment. Contractor is to submit this to the Engineer for review and approval a minimum of five working days prior to removal of existing striping and/or markings.

All pavement legends and traffic striping shall be applied in thermoplastic unless otherwise noted.

Temporary pavement marking materials must be on hand prior to the covering or demolition of existing pavement markings.

b. Scope

MATERIALS

Pavement Delineation- Thermoplastic

Thermoplastic material shall be extruded thermoplastic meeting the requirements of Section 84-2 and specifically Section 84-2.03B Extruded Thermoplastic or City approved equivalent. Placement shall be performed as directed by the manufacturer.

Legend, Shields and Arrows

Legends and arrows shall be preformed, thermoplastic pavement markings and shall be Premark 20/20 Flex Plus or a City approved equivalent. Placement shall be performed as directed by the manufacturer. Legends and symbols for preformed green bike lanes shall be factory assembled.

Preformed Thermoplastic Green Bike Lane including bike symbols, legends and arrows

Pavement Delineation- Pavement Markers

Raised and reflective pavement markers shall comply with Section 85 of the Standard Specifications. The specific type to be used shall be consistent with the type generally in use within the local jurisdiction unless directed otherwise by the Engineer.

CONSTRUCTION

All construction shall conform to the respective provisions of the Standard Specifications, manufacturer's installation requirements, and these Technical Specifications.

Existing Striping and Markings

In areas adjacent to the sealed surfacing where existing striping must be changed to conform to a revised striping pattern, conflicting striping shall be removed by sand blasting, grinding, or other methods as specified in the Standard Specifications or by the Engineer.

The Contractor shall replace all striping which has been damaged or obliterated by or during the work. This may include striping replacement completely across the street even in the event that the Contractor's work may not extend that far. All lines of each crosswalk shall be completely replaced with thermoplastic even if only a portion of a line has been obliterated.

Layout for Temporary and Permanent Striping

The alignment and layout of traffic stripes shall conform to the Standard Specifications.

The Contractor shall perform all tie downs, layout, alignment, and spotting. The Contractor shall submit a plan documenting locations, dimensions, and Caltrans Standard Detail reference number or other applicable detail for all existing pavement striping, markings, markers and legends. The plan shall contain sufficient detail for installation of new thermoplastic and markers. The plans shall be submitted five working days prior to any removal of existing striping/markings, and shall be approved by the Engineer prior to any removal activities. The Engineer or his/her designee shall review and approve striping layout prior to final striping.

The Contractor shall physically tie down the location of the beginning and ending of each paint or thermoplastic marking type in the adjacent curb top. The marking location shall not exceed fifty square inches each. Any locations exceeding this limit shall be removed by the Contractor prior to acceptance of the work. The Contractor shall contact the City Traffic Division for review of tie downs.

The Contractor shall be responsible for accurately referencing out and replacing the lines and positions of all traffic lines, directional lines, arrows, and other markings in accordance with either prior existing striping/message layout or by revised striping plans provided by the Engineer by cat tracking with painted marks. This shall occur no later than two hours after the final surface course paving operation.

Cat tracking shall consist of stretching a rope on a straight line between control points on tangent alignment and on a true arc through control points on curved alignment and placing spots of paint along the rope. Temporary tab markers shall be placed not more than twelve feet apart on curves nor more than twenty-four feet apart on straight segments.

Temporary tab markers shall be the same color as the traffic stripe that they are replacing, shall measure two inches tall by 3-1/2 inches wide, and have a reflective lens across the width of the marker.

Application of cat tracking and/or placement of temporary markers are to occur immediately upon completion of final compaction rolling and prior to opening asphalt areas to traffic. All crosswalks, stop bars and directional arrows, both yellow and white in color, shall be placed immediately upon completion of final compaction rolling and prior to opening asphalt areas to traffic. Failure to comply with these requirements shall result in a liquidated damage of \$5000 per day for each street that has not received temporary installation of the tab markers, traffic striping, and other markings. All liquidated damages in this Contract are cumulative.

Prior to application of permanent striping and markers, the Contractor shall call for review and approval of the proposed striping by the Engineer or his/her designee. The City shall have the right to make changes in the location and alignment of line stripes. Striping and traffic markings shall not be applied until approval is granted by the Engineer or his/her designee. The Contractor shall allow a minimum of seven working days for review of the layout by the City.

Crosswalks

In some instances, portions of new crosswalks will extend beyond limit of pavement rehabilitation work. In these instances, the existing 12 inch wide lines outside the paving limit shall be removed by grinding or sandblasting prior to placing new crosswalk striping.

At various locations in the project, crosswalks shall consist of a series of ten (10) foot width by two (2) foot length bars, with no perpendicular lines at the crosswalk sides, as shown in the 'Miscellaneous Details & City Standard Details' of the Contract Documents.

Schedule

Raised pavement markers (RPM's) shall be placed to replace existing RPM's or as designated by City provided striping plans. When utilizing

hot melt bituminous adhesive, RPM's shall be placed after the surface has been open to traffic for at least seven days. When utilizing epoxy adhesive, RPM's shall be placed after the surface has been open to traffic for at least fourteen days. Regardless of which adhesive is utilized, the RPM's shall not be placed more than twenty-one days after paving or surfacing.

Thermoplastic materials shall be placed to replace existing thermoplastic materials or as designated by City provided striping plans. Where green bike lanes are to be installed, the pre-formed green lanes shall be installed prior to the installation of the 6" white stripe. Permanent traffic striping and markings including legends and arrows shall be placed between eight (8) and twelve (12) days after paving or surfacing, unless otherwise directed by the Engineer. All permanent striping shall be complete in place by the 13th day after completion of resurfacing work.

Failure to comply with these requirements shall result in a liquidated damage of \$150 per day for each street that has not been cat tracked or has not received permanent installation of the required raised pavement markers, traffic striping, and markings. All liquidated damages in this Contract are cumulative.

Reflective and Raised Pavement Markers

Installation of both reflective and raised pavement markers shall conform to the provisions of Section 85 of the Standard Specifications. Pavement markers shall be placed in the same pattern and locations as they were previously, except as specified by the Engineer.

Reflective Pavement Markers at fire hydrants shall consist of placing a single blue marker on the new pavement surface. Location of the new marker shall be six (6) inches off of the lane striping nearest to and in line with the existing fire hydrant.

Pavement Delineation- Thermoplastic

Pavement temperature shall be measured at the beginning of the shift on each working day and this information shall be provided to the Traffic Engineer.

No primer or thermoplastic shall be installed within forty-eight hours from the last measurable rain report as provided by the City.

Thermoplastic traffic striping, legends, and arrows shall conform to the provisions of Section 84-of the Standard Specifications and these Technical Provisions.

c. Measurement & Payment

Payment for traffic striping layout and placement of temporary lane markers will be included in the unit price bid for each striping detail as identified in the Bid Schedule and no additional compensation will be allowed therefore.

Measurement and payment for pavement striping, characters, arrows, pavement markers, raised pavement markers, and reflective pavement markers shall be paid on a unit cost basis as identified in the Bid Schedule.

Payment for any striping removal as identified herein shall be included in the unit price for the related striping item and no additional compensation will be allowed therefore.

The above contract unit costs shall be considered full compensation for furnishing all labor, materials, tools, equipment, transportation, and incidentals; and for performing all of the work involved as detailed in the Standard Specifications, these Technical Specifications, and the plans and typical sections. No additional compensation will be allowed therefore.

End Technical Specifications

DIST#	COUNTY	ROUTE	FIRST MILE TOTAL PROJECT	SHEET TOTAL NO. SHEETS

REGISTERED CIVIL ENGINEER
 MAY 1, 2023
 YOUR M.O.D. NO. C20265
 DATE
 THE STATE OF CALIFORNIA DEPARTMENT OF TRANSPORTATION
 THIS STATE OF CALIFORNIA DEPARTMENT OF TRANSPORTATION
 OR AGENCIES SHALL NOT BE RESPONSIBLE FOR
 THE ACCURACY OR COMPLETENESS OF THESE PLANS SHEETS.

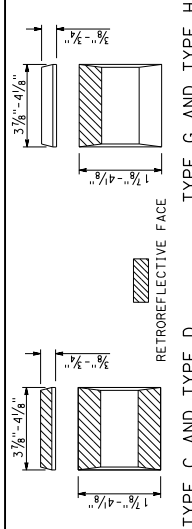

MARKER DETAILS

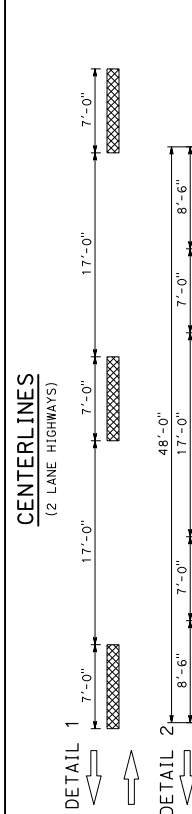

NO PASSING ZONES - ONE DIRECTION

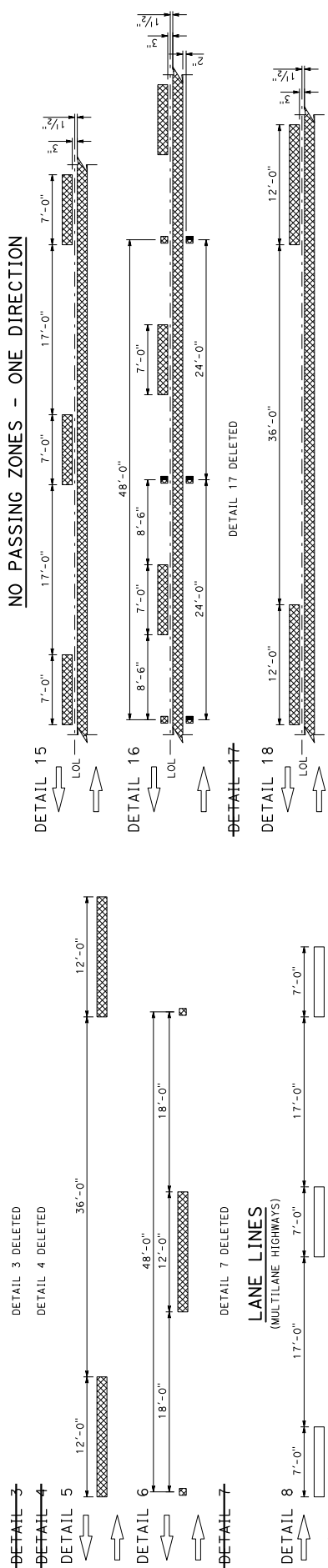

NO PASSING ZONES - TWO DIRECTION

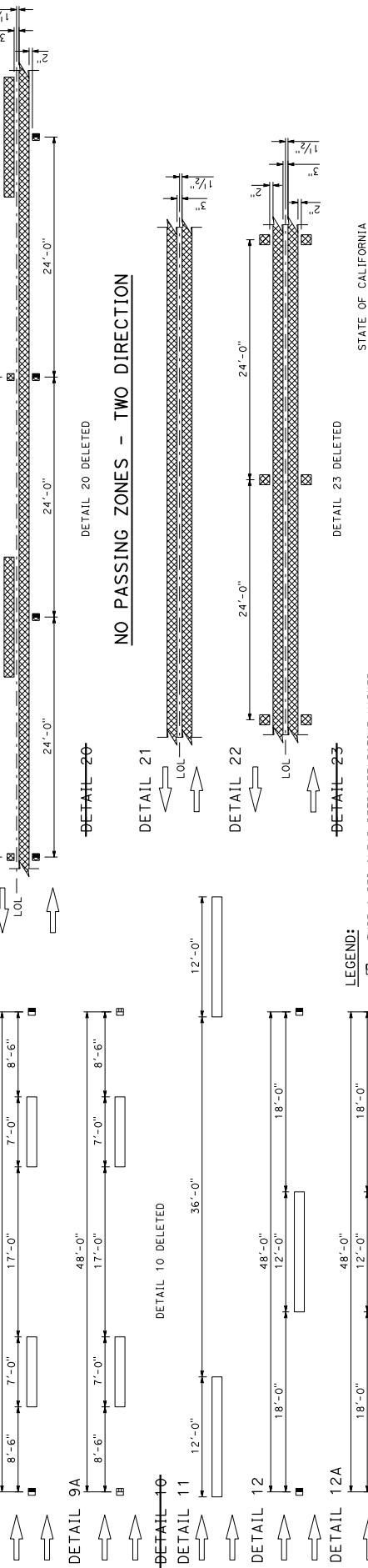

- LEGEND:**
- TYPE C RED-CLEAR RETROREFLECTIVE MARKER
 - TYPE D TWO-WAY YELLOW RETROREFLECTIVE MARKER
 - TYPE G ONE-WAY CLEAR RETROREFLECTIVE MARKER
 - TYPE H ONE-WAY YELLOW RETROREFLECTIVE MARKER
 - 6" WHITE LINE
 - 6" YELLOW LINE

STATE OF CALIFORNIA
 DEPARTMENT OF TRANSPORTATION
PAVEMENT MARKERS AND TRAFFIC LINES
TYPICAL DETAILS
 NO SCALE

A20A

DIST#	COUNTY	ROUTE	POST MILES TOTAL PROJECT	SHEET TOTAL NO. SHEETS

REGISTERED CIVIL ENGINEER
 MAY 1, 2023
 YOUR M.O.D. NO. C20265
 EXPIRES 3-31-24
 THE STATE OF CALIFORNIA HAS THE AUTHORITY TO REVOKE THE LICENSE OF ANY ENGINEER WHOSE LICENSE IS FOUND TO BE IN VIOLATION OF THE PROFESSIONAL ENGINEER ACT.
 THIS STATE OF CALIFORNIA SEAL IS NOT VALID UNLESS IT IS REGISTERED AND THE ENGINEER'S NAME IS ON THE LIST OF REGISTERED ENGINEERS.
 THE STATE OF CALIFORNIA SHALL NOT BE RESPONSIBLE FOR ANY ERRORS OR OMISSIONS ON THIS SHEET OR ANY OTHER SHEETS OF THIS PLAN SHEET.

- LEGEND:**
- TYPE D TWO-WAY YELLOW RETROREFLECTIVE MARKER
 - TYPE H ONE-WAY YELLOW RETROREFLECTIVE MARKER
 - TYPE RY RED-YELLOW RETROREFLECTIVE MARKER
 - 6" WHITE LINE
 - 6" YELLOW LINE

MEDIAN ISLANDS

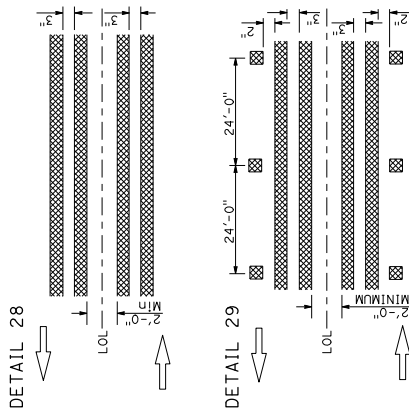

LEFT EDGE LINES
(DIVIDED HIGHWAYS)
See Note

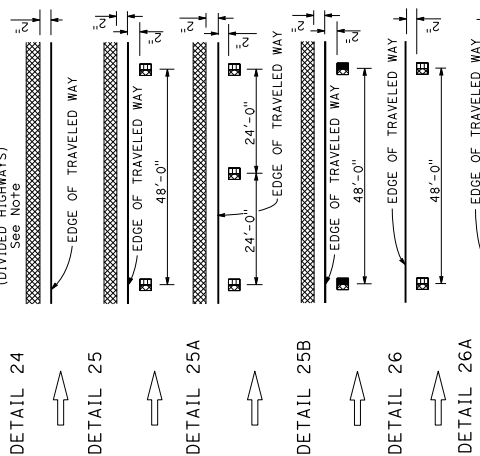

RIGHT EDGE LINES

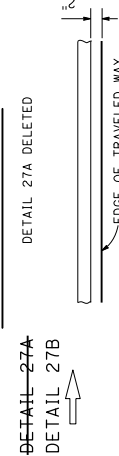

RIGHT EDGE LINE EXTENSION THROUGH INTERSECTIONS

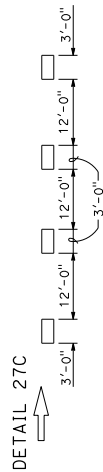

LEFT EDGE LINES NOTE:
On freeways use traffic stripe details with Type RY markers.

INTERSECTION TREATMENTS

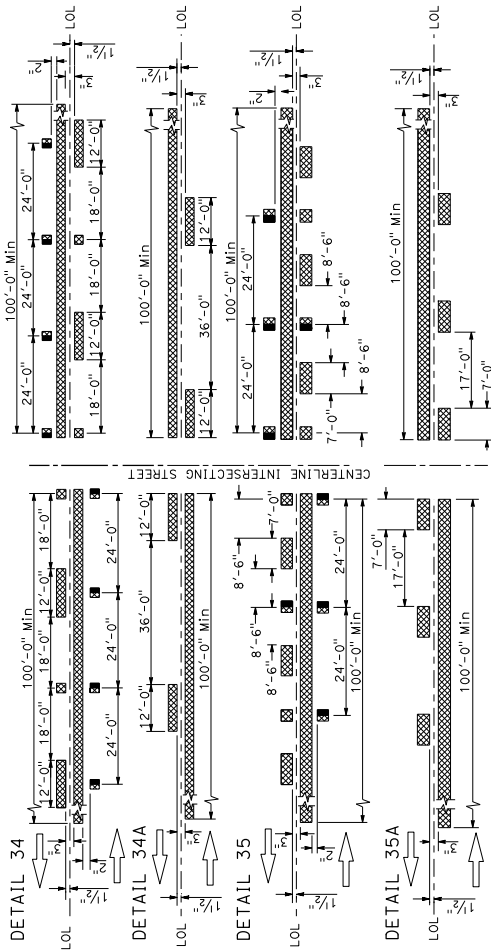

TWO-WAY LEFT TURN LANES

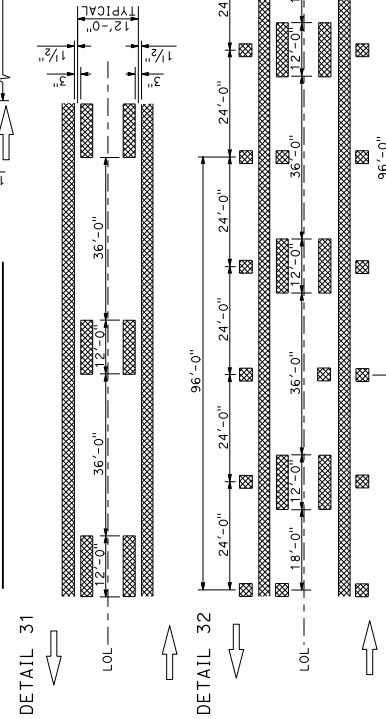

MARKER DETAILS

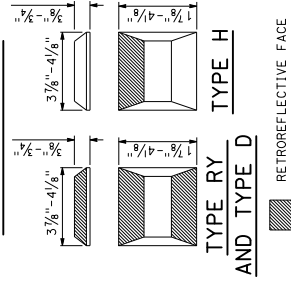

STATE OF CALIFORNIA
 DEPARTMENT OF TRANSPORTATION
PAVEMENT MARKERS AND TRAFFIC LINES
TYPICAL DETAILS
 NO SCALE

A 20B

DIST	COUNTY	ROUTE	POST MILE TOTAL PROJECT	SHEET TOTAL NO. SHEETS

REGISTERED CIVIL ENGINEER

MAY 1, 2023

YOUR M.O.D. NO. CR2065

DATE

PROJECT NO. 3-31-24

DATE

STATE OF CALIFORNIA

REGISTERED CIVIL ENGINEER

PROFESSIONAL ENGINEER

NO. 171, 071708

THIS STATE OF CALIFORNIA LICENSE IS VALID FOR THE PRACTICE OF CIVIL ENGINEERING ONLY. ANY OTHER TYPE OF PRACTICE OR ANY OTHER TYPE OF PROFESSIONAL SERVICE SHALL NOT BE RESPONSIBLE FOR THE CONTENTS OF THIS PLAN SHEET.

NOTES:
 Install a minimum of 1 chevron in the gore area, if at least 1 chevron will not fit into the gore area, do not install chevrons. Terminate chevron markings at physical gore.
 Gore area chevron pavement markings shown. For Exit and Entrance Ramp channelizing lines details, see Details 36, 36A, and 36B.

LANE DROP AT EXIT RAMPS

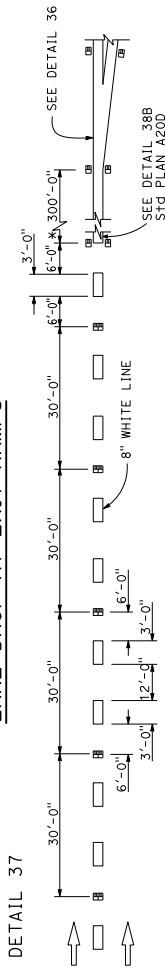

* The solid channelizing line shown may be omitted on short auxiliary lanes where weaving length is critical.

DETAIL 37A DELETED

LANE DROP AT INTERSECTIONS

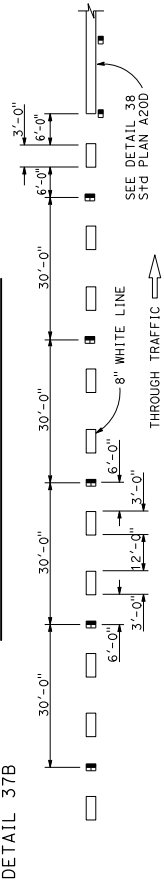

DETAIL 37C DELETED

CHEVRON PAVEMENT MARKINGS AT EXIT RAMP GORE AREA

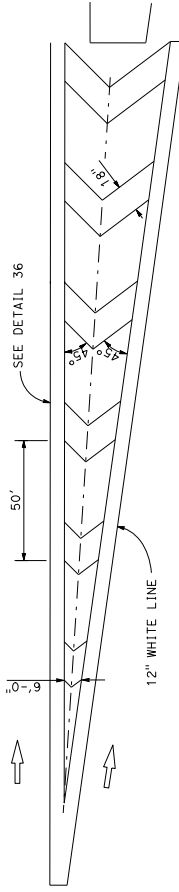

CHEVRON PAVEMENT MARKINGS AT ENTRANCE RAMP GORE AREA

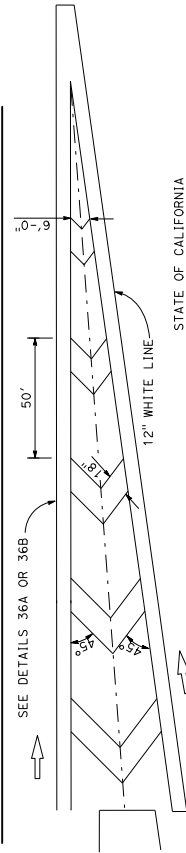

STATE OF CALIFORNIA
 DEPARTMENT OF TRANSPORTATION

**PAVEMENT MARKERS AND TRAFFIC LINES
 TYPICAL DETAILS**

NO SCALE

A 20C

EXIT RAMP NEUTRAL AREA (GORE) TREATMENT

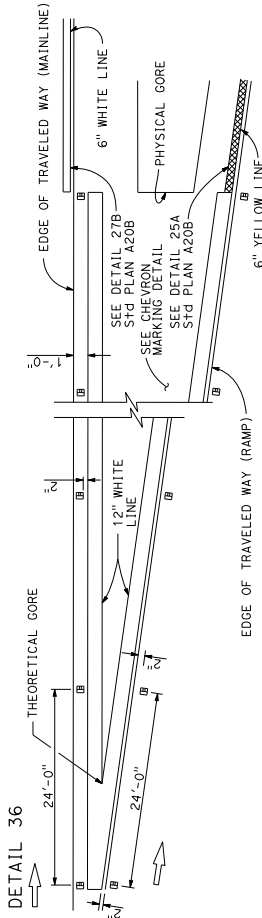

ENTRANCE RAMP NEUTRAL AREA (MERGE) TREATMENT

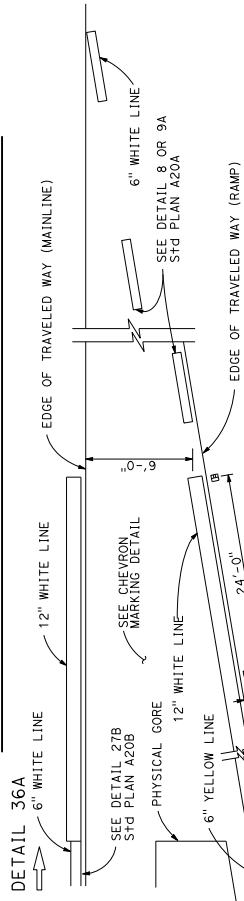

ENTRANCE RAMP NEUTRAL AREA (ACCELERATION LANE) TREATMENT

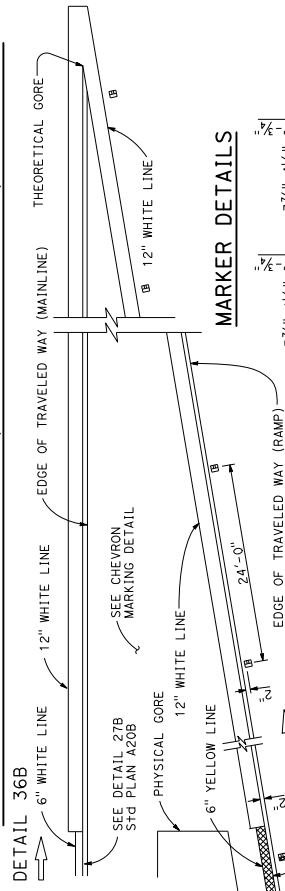

MARKER DETAILS

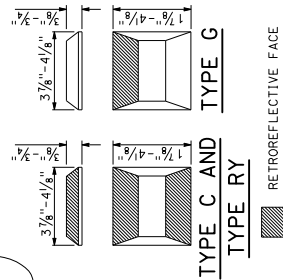

LEGEND:

- TYPE C RED-CLEAR RETROREFLECTIVE MARKER
- TYPE G ONE-WAY CLEAR RETROREFLECTIVE MARKER
- TYPE RY RED-YELLOW RETROREFLECTIVE MARKER

RETROREFLECTIVE FACE

DIST.	COUNTY	ROUTE	POST MILE TOTAL PROJECT	SHEET TOTAL NO. SHEETS

REGISTERED CIVIL ENGINEER

PROFESSIONAL ENGINEER

YOUR M.O.D. No. CR2065

DATE MAY 1, 2023

THE STATE OF CALIFORNIA DEPARTMENT OF TRANSPORTATION

FOR THIS PROJECT, THE DESIGNER SHALL NOT BE RESPONSIBLE FOR THE ACCURACY OF THE DATA OR THE COMPLETION OF THIS PLAN SHEET.

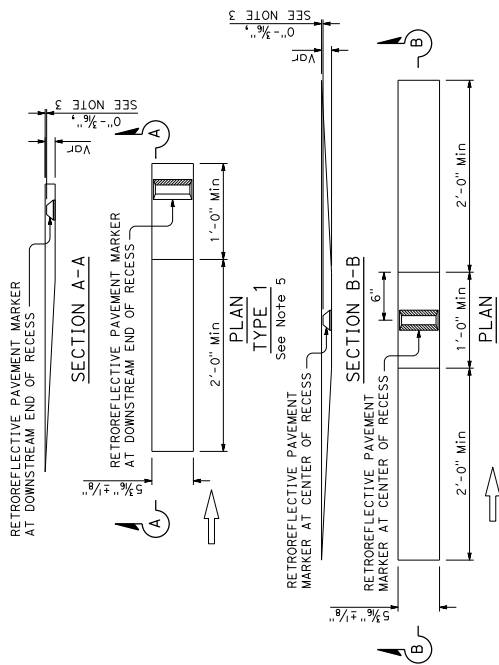

RECESS DETAIL FOR RETROREFLECTIVE PAVEMENT MARKER

RECESSED MARKER NOTES:

1. See typical traffic line details for marker patterns to be used with recessed pavement markers.
2. The retroreflective pavement markers shown for recessed installations are not to be used for non-recessed installations.
3. The top of pavement markers installed in recesses shall be 0" to 1/8" below the pavement surface.
4. Use Type 1 recess for pavement markers with one-way retroreflective face. Use Type 2 recess for pavement markers with two-way retroreflective face.
5. For exit ramps, use Type 1 recess for pavement markers. The orientation of the recess and place the marker at the upstream end of the recess.

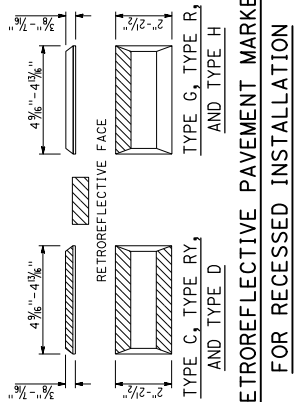

RETROREFLECTIVE PAVEMENT MARKER FOR RECESSED INSTALLATION

See Notes 1 and 2

PAVEMENT MARKERS AND TRAFFIC LINES TYPICAL DETAILS

NO SCALE

A 20D

CHANNELIZING LINE

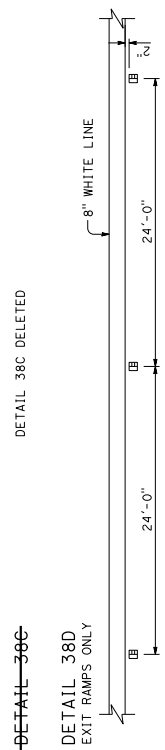
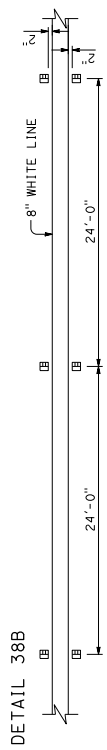
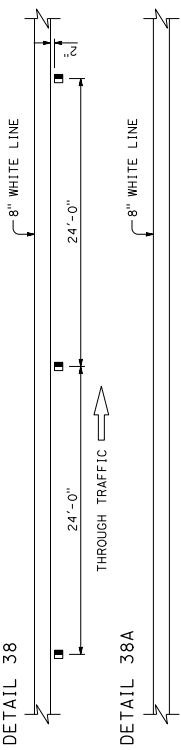

BIKE LANE



INTERSECTION BIKE LANE

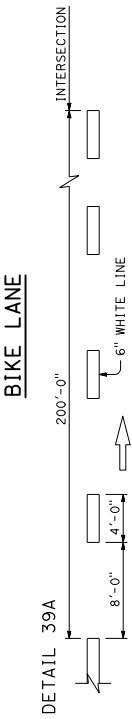

LANE LINE EXTENSIONS THROUGH INTERSECTIONS

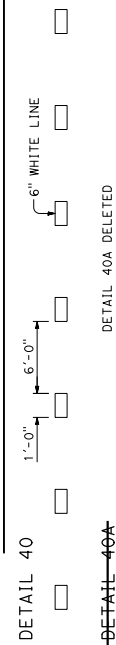

CENTERLINE EXTENSIONS THROUGH INTERSECTIONS

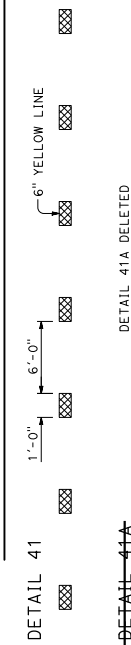

LEGEND:

- TYPE C RED-CLEAR RETROREFLECTIVE MARKER
- TYPE G ONE-WAY CLEAR RETROREFLECTIVE MARKER
- 6" YELLOW LINE

DETAIL FOR RECESSED TRAFFIC STRIPE

See Notes A and B

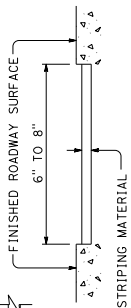

RECESSED NOTES:

- A. See typical traffic line details for pavement marking patterns.
- B. See Standard Specifications for material thickness.

DIST	COUNTY	ROUTE	FIRST MILE TOTAL PROJECT	SHEET TOTAL NO. SHEETS

REGISTERED CIVIL ENGINEER	PROFESSIONAL ENGINEER
MAY 1, 2023	YOUR MIDDLE INITIAL
DATE	NO. CR2065
EXPIRES ON	EXPIRES ON
NO. 3-31-24	NO. 3-31-24
CIVIL	CIVIL
STATE OF CALIFORNIA	STATE OF CALIFORNIA

REGISTERED CIVIL ENGINEER

REGISTERED CIVIL ENGINEER

NO. 3-31-24

EXPIRES ON

EXPIRES ON

NO. 3-31-24

CIVIL

CIVIL

STATE OF CALIFORNIA

STATE OF CALIFORNIA

TYPICAL DOUBLE STRIPE CONTRAST DETAIL

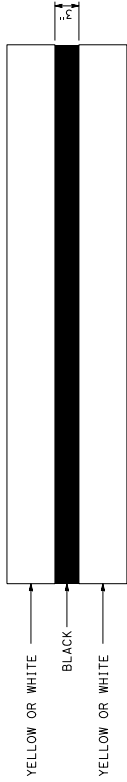

NOTES:

1. See Standard Plans A20A, A20B, A20C, A20D and A20F for traffic lines typical details.
2. Detail 9 Traffic stripe shown. See project plans for traffic stripe details.

OPTION 1

TYPICAL LANE LINE OR RIGHT EDGE LINE CONTRAST DETAIL



OPTION 2

TYPICAL LANE LINE CONTRAST DETAIL

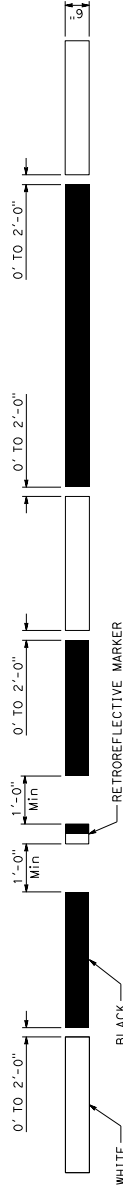

See Note 2

STATE OF CALIFORNIA
DEPARTMENT OF TRANSPORTATION
**TRAFFIC LINES
TYPICAL DETAILS
FOR CONTRAST STRIPING**
NO. SCALE

A 20E

DIST	COUNTY	ROUTE	FIRST MILE TOTAL PROJECT	SHEET TOTAL NO. SHEETS

REGISTERED CIVIL ENGINEER	
YOUR NO. CE2065	YOUR EXPIRATION DATE 3-31-24
THE STATE OF CALIFORNIA DEPARTMENT OF TRANSPORTATION AND HIGHWAYS SHALL NOT BE RESPONSIBLE FOR THE ACCURACY OF THIS PLAN SHEET UNLESS OTHERWISE SPECIFIED	

PREFERENTIAL LANE LINES



~~DETAIL 43~~ DETAIL 43 DELETED

~~DETAIL 43A~~ DETAIL 43A DELETED

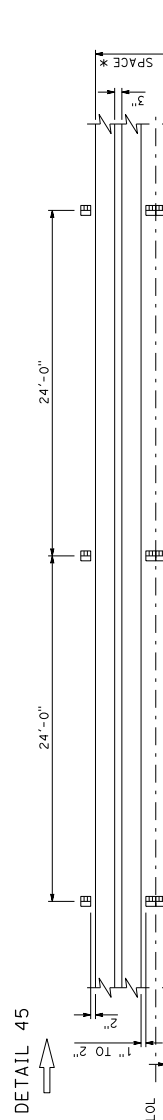
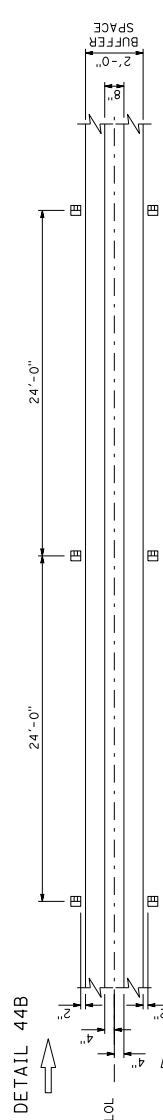
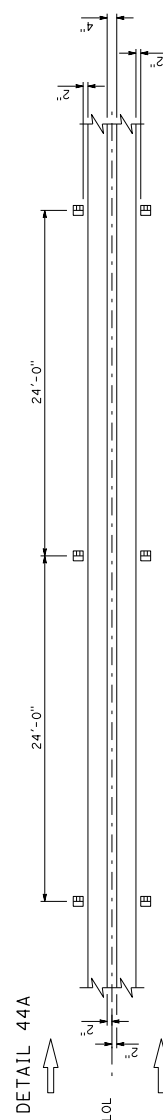

* See pavement delineation plan for dimension.

- LEGEND:**
- TYPE C RED-CLEAR RETROREFLECTIVE MARKER
 - 8" WHITE LINE

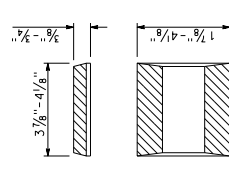

RETROREFLECTIVE FACE
TYPE C
MARKER DETAILS

STATE OF CALIFORNIA
DEPARTMENT OF TRANSPORTATION
PAVEMENT MARKERS AND TRAFFIC LINES
TYPICAL DETAILS
NO SCALE

A 20F

DIST	COUNTY	ROUTE	POST MILES TOTAL PROJECT	SHEET TOTAL NO. SHEETS

REGISTERED CIVIL ENGINEER
 MAY 1, 2023
 YOUR NO. CE2065
 DATE
 THE STATE OF CALIFORNIA DEPARTMENT OF TRANSPORTATION
 FOR AGENCIES SHALL NOT BE RESPONSIBLE FOR THE CORRECTNESS OF THIS PLAN SHEET.

LEGEND:

- MARKERS**
- TYPE C TWO-WAY RED-CLEAR RETROREFLECTIVE MARKER
 - TYPE RY TWO-WAY RED-YELLOW RETROREFLECTIVE MARKER
 - TYPE R ONE-WAY RED RETROREFLECTIVE MARKER
- LINES**
- 6" WHITE LINE
 - 6" YELLOW LINE

- NOTES:**
1. May be a limit line or crosswalk.
 2. See Standard Plans A24F and A24G for crosswalk and pavement marker details.
 3. For raised markers, place Type R one-way red retroreflective markers on limit lines, crosswalks, or other pavement markings facing the intersection. For recessed markers, place Type R one-way retroreflective markers with red facing the intersection and as shown on Standard Plan A24G.
 4. The distances and marker spacings may be adjusted based on site specific conditions, exit ramp geometry, or loop detectors.
 5. See Standard Plan A200 for recess details.
 6. See Standard Plan A24G for Type V arrow detail with Type R one-way red retroreflective markers.
 7. The Type R marker body must be white in color.

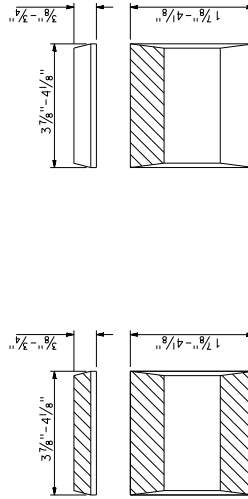
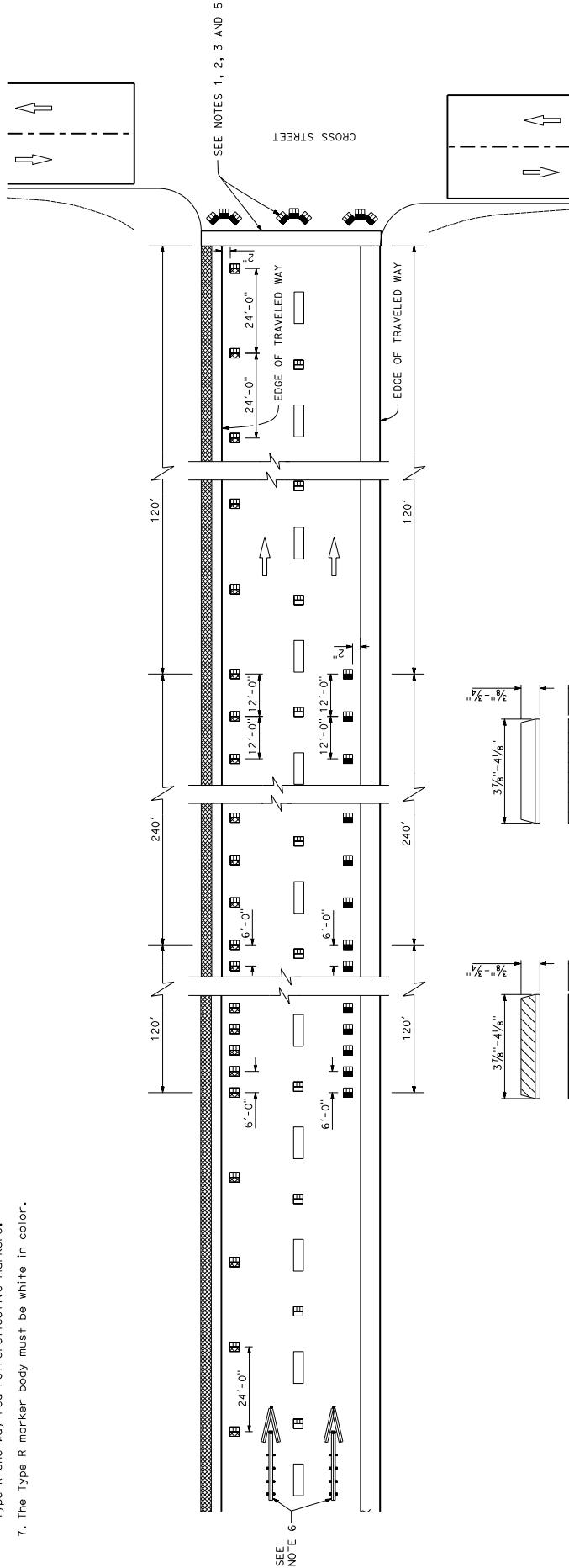

MARKER DETAILS

RETROREFLECTIVE FACE

STATE OF CALIFORNIA
 DEPARTMENT OF TRANSPORTATION
EXIT RAMP WITH ENHANCED PAVEMENT MARKERS FOR WRONG WAY DETAILS
 NO SCALE
A 20G

DIST	COUNTY	ROUTE	FIRST MILE TOTAL PROJECT	SHEET TOTAL NO. SHEETS

REGISTERED CIVIL ENGINEER
 No. CR2065
 Exp. 3-31-24
 STATE OF CALIFORNIA
 PROFESSIONAL ENGINEER

DATE: MAY 1, 2023
 YOUR M.O.D. No. CR2065
 PROJECT: COUNTY OF LOS ANGELES FOR ITS OFFICERS
 THE STATE OF CALIFORNIA
 ANY AGENTS SHALL NOT BE RESPONSIBLE FOR THE ACCURACY OR COMPLETENESS OF THESE PLANS SHEETS.

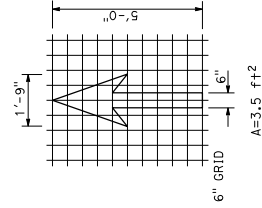
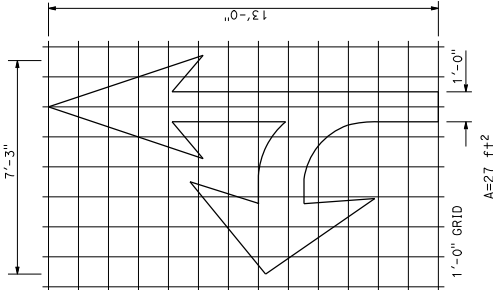
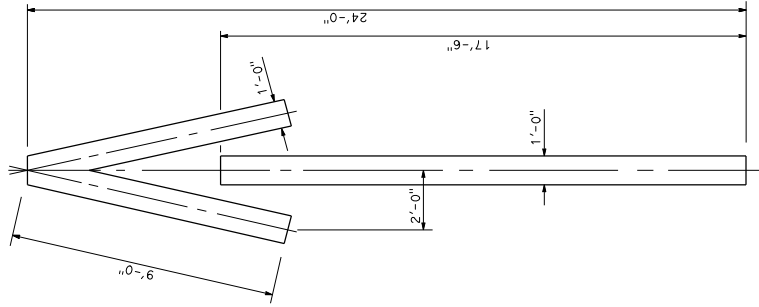
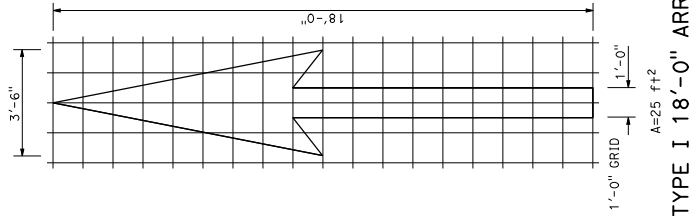
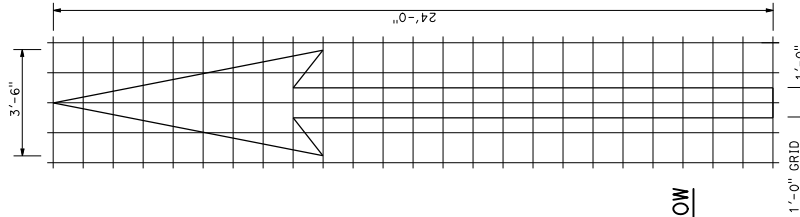
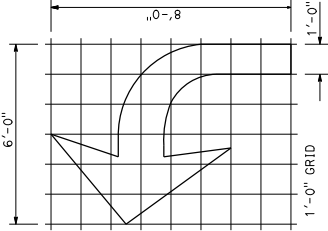
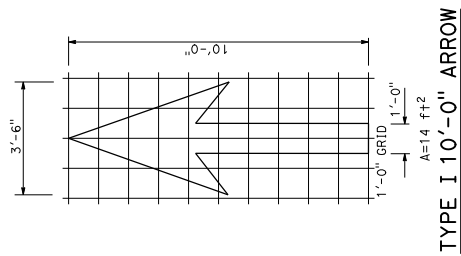
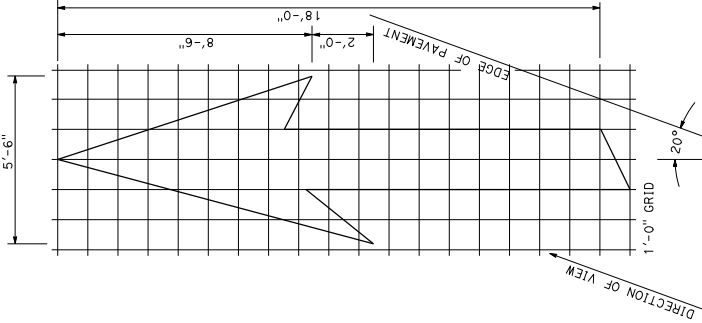
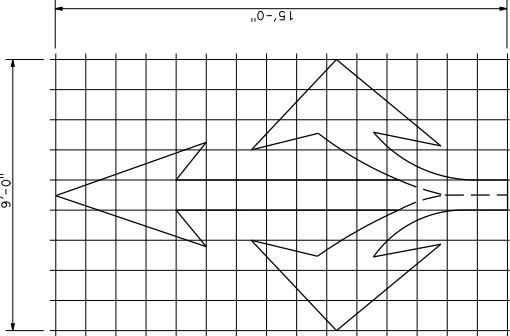

NOTE:
 Minor variations in dimensions may be accepted by the Engineer.

STATE OF CALIFORNIA
 DEPARTMENT OF TRANSPORTATION
**PAVEMENT MARKINGS
 ARROWS**
 NO SCALE

A 24A

For Type III (R) arrow, use mirror image.

For Type IV (R) arrow, use mirror image.

DIST	COUNTY	ROUTE	POST MILE TOTAL PROJECT	SHEET TOTAL NO. SHEETS

REGISTERED CIVIL ENGINEER
 MAY 1, 2023
 YOUR M.O.D. NO. CR2065
 DATE OF EXPIRATION OF LICENSE
 THE STATE OF CALIFORNIA OR ITS OFFICERS OR AGENCIES SHALL NOT BE RESPONSIBLE FOR THE ACCURACY OR COMPLETENESS OF ANY INFORMATION CONTAINED ON THIS PLAN SHEET.

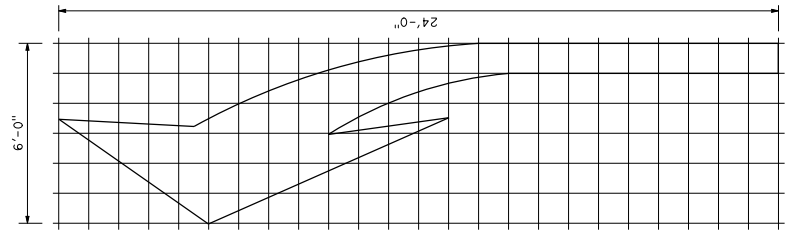
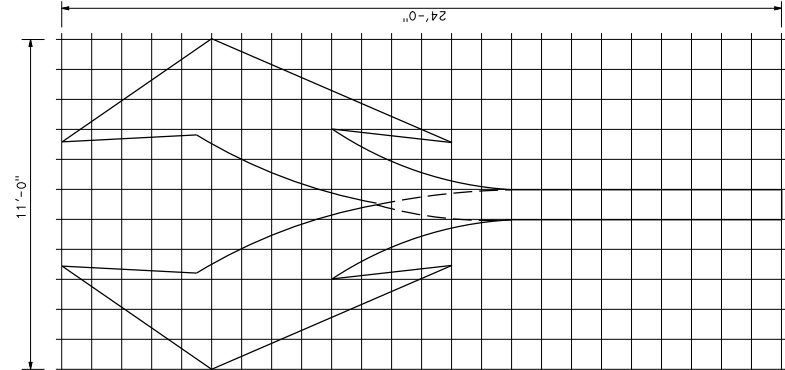
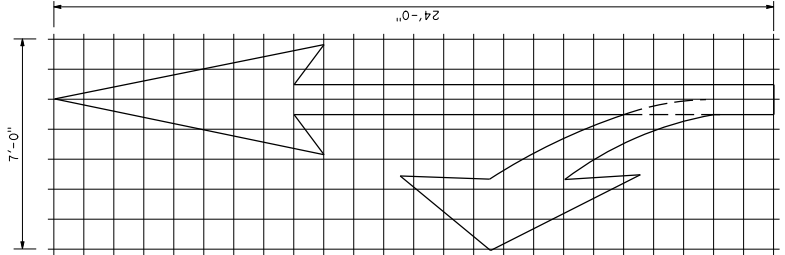
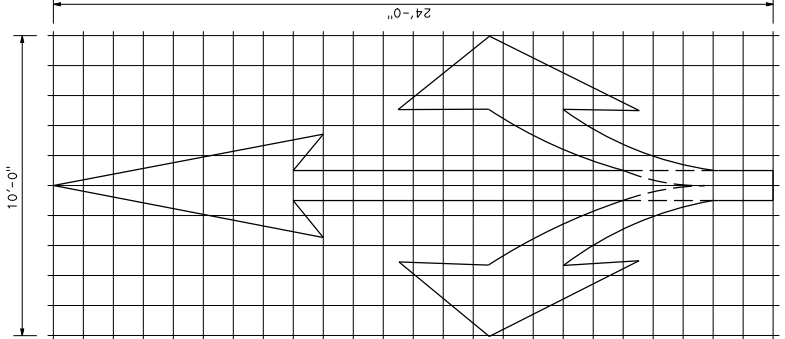
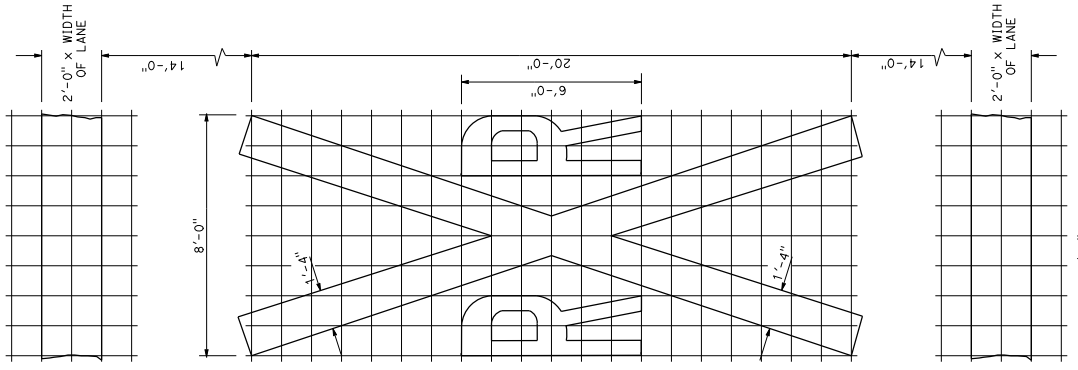

TYPE II (B) ARROW
 A=59 ft²
 STATE OF CALIFORNIA
 DEPARTMENT OF TRANSPORTATION
**PAVEMENT MARKINGS
 ARROWS AND SYMBOLS**
 NO SCALE

TYPE II (L) ARROW
 A=45 ft²
 For Type II (R) use mirror image.

TYPE III (B) ARROW
 A=73 ft²

TYPE III (L) ARROW
 A=42 ft²
 For Type III (R) use mirror image.

NOTE:
 Minor variations in dimensions may be accepted by the Engineer.

RAILROAD CROSSING SYMBOL
 1'-0" GRID
 A=70 ft² *
 * 70 ft² does not include the 2'-0" x variable width transverse lines.

A 24B

Return to Table of Contents

DIST	COUNTY	ROUTE	POST MILE TOTAL PROJECT	SHEET TOTAL NO. SHEETS

REGISTERED CIVIL ENGINEER
 MAY 1, 2023
 DATE
 CIVIL ENGINEER
 NO. C82065
 Exp. 3-31-24
 STATE OF CALIFORNIA
 PROFESSIONAL ENGINEER

THE STATE OF CALIFORNIA DEPARTMENT OF TRANSPORTATION
 OR ITS OFFICERS
 OR AGENTS SHALL NOT BE RESPONSIBLE FOR
 THE ACCURACY OR COMPLETENESS OF ANY
 DIMENSIONS OR INFORMATION SHOWN ON THIS SHEET,
 UNLESS SPECIFICALLY NOTED OTHERWISE.

NOTE:
 Minor variations in dimensions may be accepted by the Engineer.

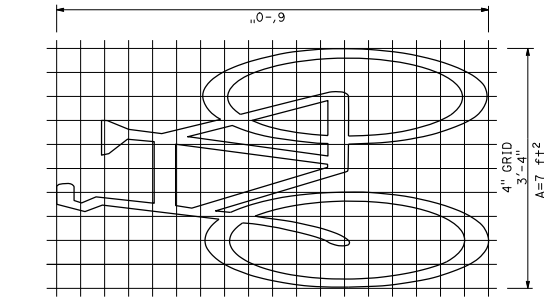
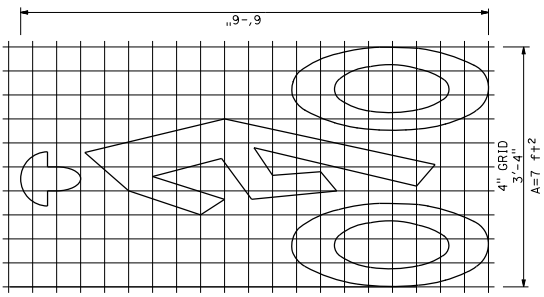
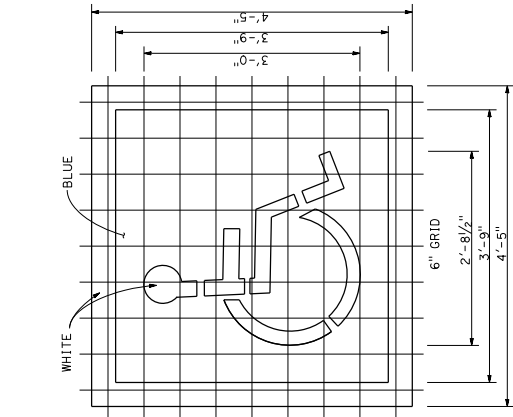
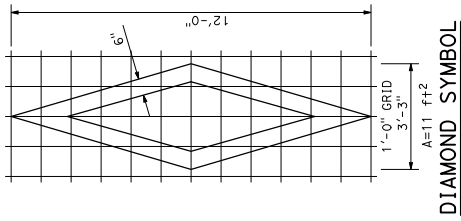

INTERNATIONAL SYMBOL OF ACCESSIBILITY (ISA) MARKING

BIKE LANE SYMBOL WITH PERSON

BIKE LANE SYMBOL WITHOUT PERSON

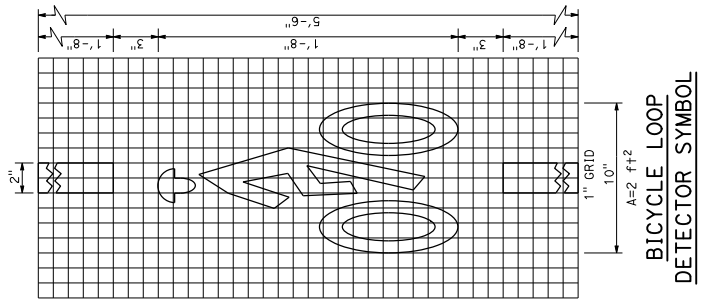
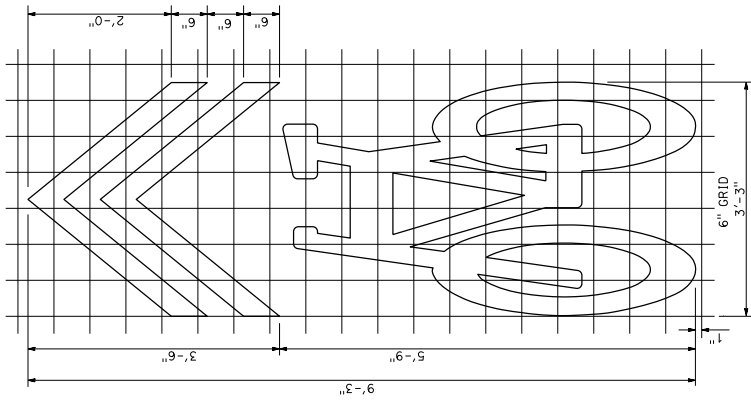
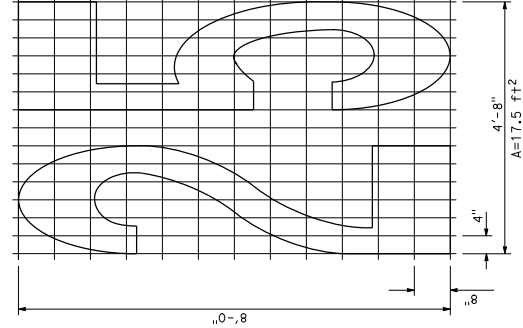
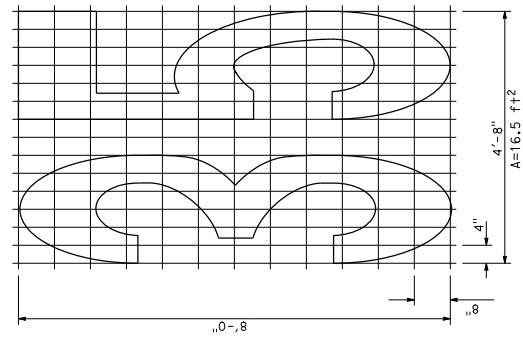
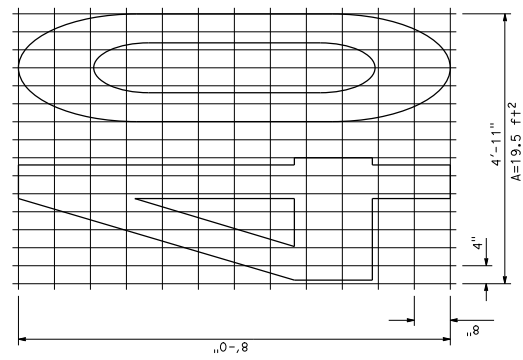

STATE OF CALIFORNIA
 DEPARTMENT OF TRANSPORTATION

PAVEMENT MARKINGS SYMBOLS AND NUMERALS
 NO. SCALE

A 24C

DIST	COUNTY	ROUTE	POST MILE TOTAL PROJECT	SHEET TOTAL NO. SHEETS

REGISTERED CIVIL ENGINEER

MAY 1, 2023

YOUR WORD NO. CR2065

DATE

PROFESSIONAL ENGINEER

STATE OF CALIFORNIA

THE STATE OF CALIFORNIA DEPARTMENT OF TRANSPORTATION

NO. 3-31-24

CIVIL

THIS CERTIFICATE IS VALID FOR THE OFFICER'S TERM OF OFFICE AND IS NOT BE RESPONSIBLE FOR ANY ERRORS OR OMISSIONS OF THIS PLAN SHEET.

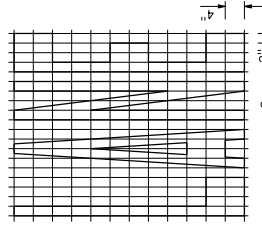
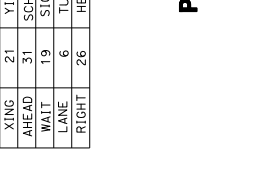
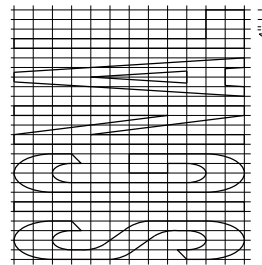
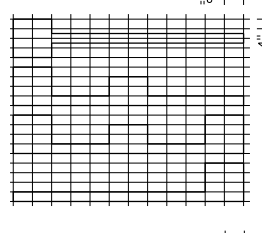
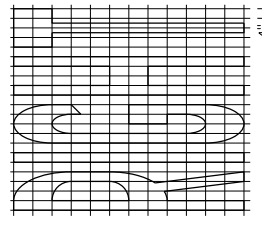
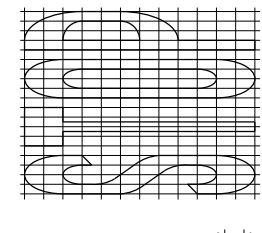
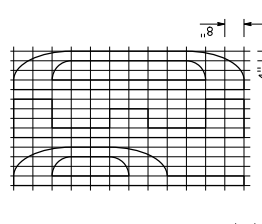
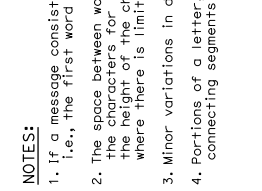
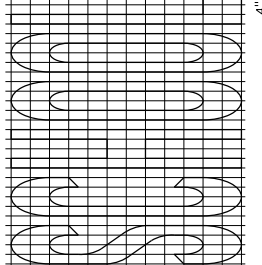
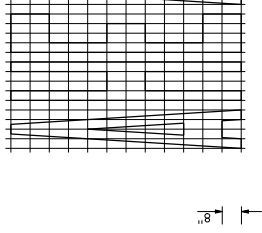
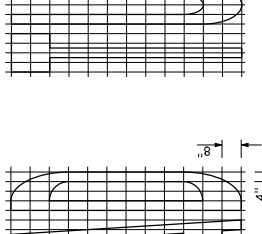
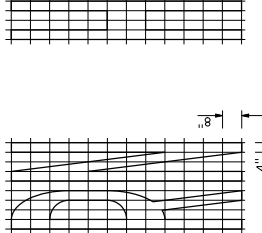
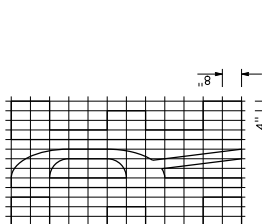
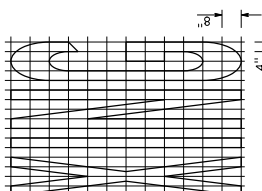
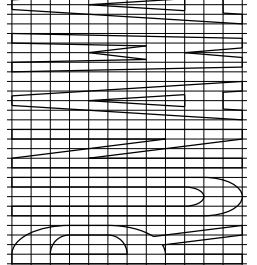
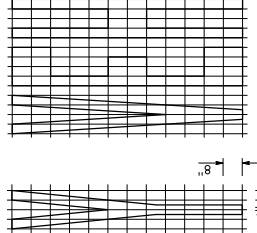
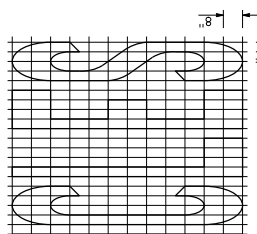
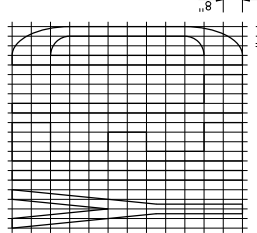
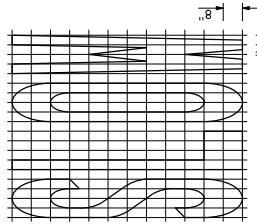
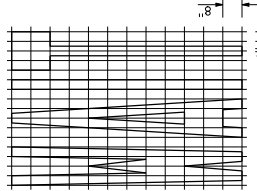

NOTES:

- If a message consists of more than one word, it must read "UP", i.e., the first word must be nearest the driver.
- The space between words must be at least four times the height of the characters for low speed roads, but not more than ten times the height of the characters. The space may be reduced appropriately where there is limited space because of local conditions.
- Minor variations in dimensions may be accepted by the Engineer.
- Portions of a letter, number or symbol may be separated by connecting segments not to exceed 2" in width.

WORD MARKINGS					
ITEM	f+2	ITEM	f+2	ITEM	f+2
XING	21	YIELD	24	BIKE	5
AHEAD	31	SCHOOL	35	SLOW	23
WAIT	19	SIGNAL	32	STOP	22
LANE	6	TURN	24	LEFT	19
RIGHT	26	HERE	26	VEHICLES	42

STATE OF CALIFORNIA
DEPARTMENT OF TRANSPORTATION

PAVEMENT MARKINGS
WORDS
NO SCALE

A 24D

DIST	COUNTY	ROUTE	POST MILE TOTAL PROJECT	SHEET TOTAL NO. SHEETS

REGISTERED CIVIL ENGINEER
 MAY 1, 2023 DATE
 CIVIL ENGINEER
 No. CR2065
 Exp. 3-31-24
 THE STATE OF CALIFORNIA DEPARTMENT OF TRANSPORTATION
 ALL AGENTS SHALL NOT BE RESPONSIBLE FOR THE ACCURACY OR COMPLETENESS OF THESE PLANS SHEETS.

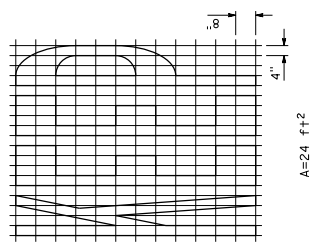
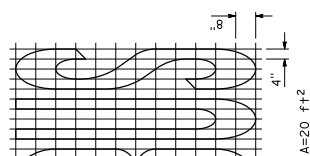
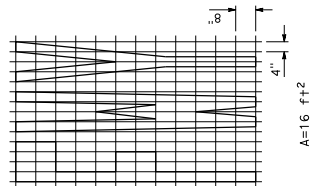
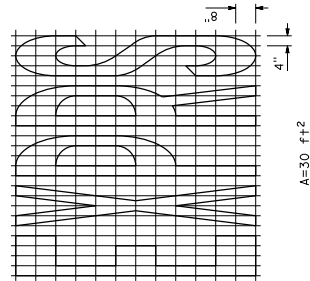
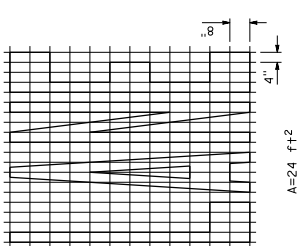
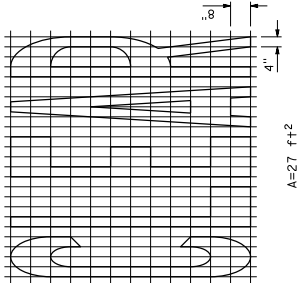
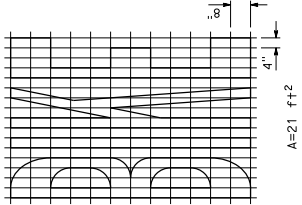
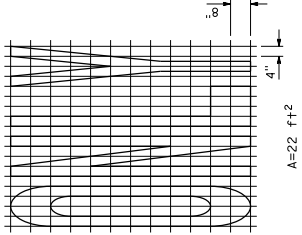

ITEM	SOFT	ITEM	SOFT
LANE	24	NO	14
CLEAR	27	BIKE	21
KEEP	24	BUS	20
HOV	18	ONLY	22
TRAIL	23	FWY	16
EXPRS	30		

NOTES:

- If a message consists of more than one word, it must read "up", i.e., the first word must be nearest the driver.
- The space between words must be at least four times the height of the characters for low speed roads, but not more than ten times the height of the characters. The space may be reduced appropriately where there is limited space because of local conditions.
- Minor variations in dimensions may be accepted by the Engineer.
- Portions of a letter, number, or symbol may be separated by connecting segments not to exceed 2" in width.
- The words "NO PARKING" pavement marking is to be used for parking facilities. For typical characters or markings, see Standard Plans A904 and A908.
- The words "NO PARKING", shall be painted in white letters no less than 1'-0" high on a contrasting background and located so that it is visible to traffic enforcement officials.

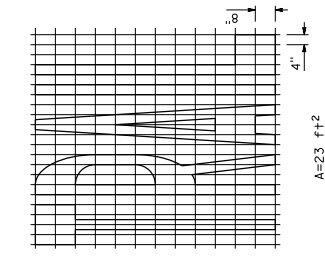
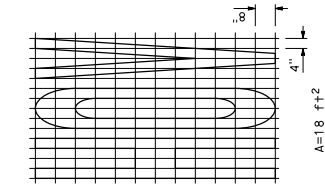
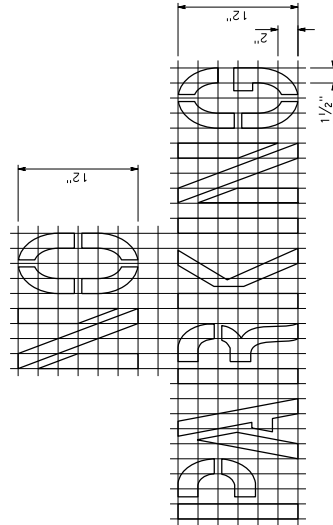

STATE OF CALIFORNIA
 DEPARTMENT OF TRANSPORTATION
PAVEMENT MARKINGS
WORDS
 NO SCALE

A 24E

Return to Table of Contents

DIST	COUNTY	ROUTE	POST MILE TOTAL PROJECT	SHEET TOTAL NO. SHEETS

REGISTERED CIVIL ENGINEER	
YOUR NO. CR2065	YOUR EXPIRATION DATE 3-31-24
REGISTERED PROFESSIONAL ENGINEER STATE OF CALIFORNIA	

DATE	PROJECT NO.	PROJECT NAME
MAY 1, 2023		

THE STATE OF CALIFORNIA DEPARTMENT OF TRANSPORTATION
 DIVISION OF HIGHWAYS
 THIS DRAWING IS THE PROPERTY OF THE STATE OF CALIFORNIA
 AND SHALL NOT BE REPRODUCED OR TRANSMITTED IN ANY FORM OR BY ANY MEANS
 WITHOUT THE WRITTEN PERMISSION OF THE STATE OF CALIFORNIA

NOTES:

1. Spaces between markings must be placed in wheel tracks of each lane.
2. Spacings not to exceed 2.5 x width of longitudinal line.
3. All crosswalk markings must be white except those near schools must be yellow.

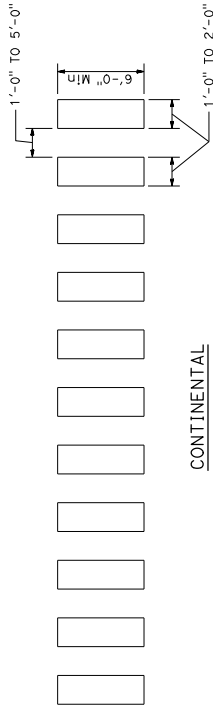

CONTINENTAL
See Note 1

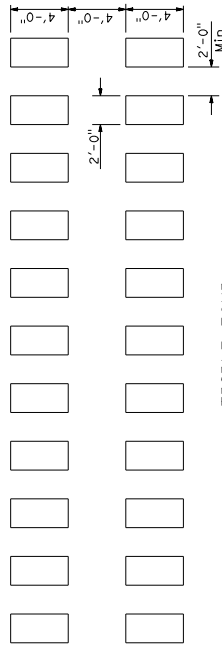

TRIPLE FOUR
See Note 1

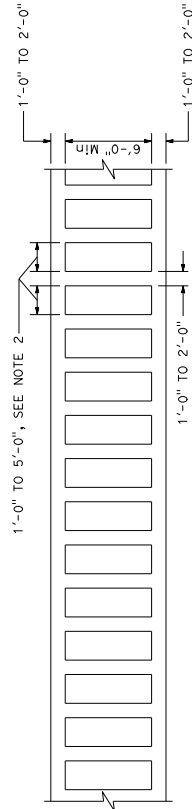

LADDER

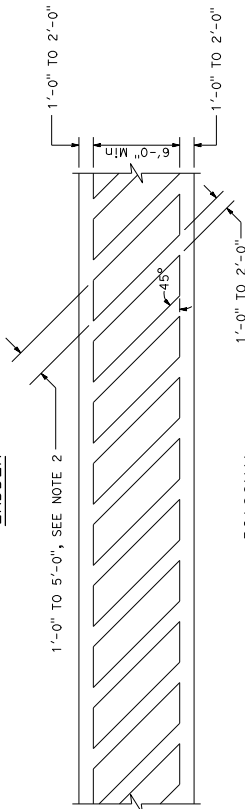

DIAGONAL

HIGHER VISIBILITY CROSSWALKS

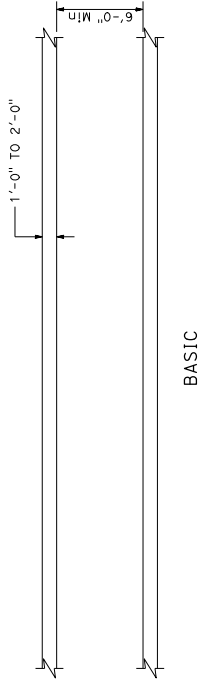

BASIC

STATE OF CALIFORNIA
 DEPARTMENT OF TRANSPORTATION
**PAVEMENT MARKINGS
 CROSSWALKS**
 NO. SCALE

A 24F

DIST	COUNTY	ROUTE	POST MILES TOTAL PROJECT	SHEET TOTAL NO. SHEETS

REGISTERED CIVIL ENGINEER
 MAY 1, 2023
 YOUR M.O.D. NO. CR2065
 DATE 3-31-24
 CIVIL
 STATE OF CALIFORNIA
 THE STATE OF CALIFORNIA OR ITS OFFICERS OR AGENCIES SHALL NOT BE RESPONSIBLE FOR THE ACCURACY OR COMPLETENESS OF ANY INFORMATION CONTAINED ON THIS PLAN SHEET.

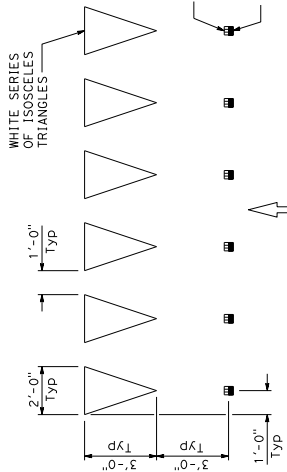

YIELD LINE AT EXIT RAMP
 (Markers are recessed)

LEGEND:
 TYPE R, ONE-WAY RED RETROREFLECTIVE MARKER

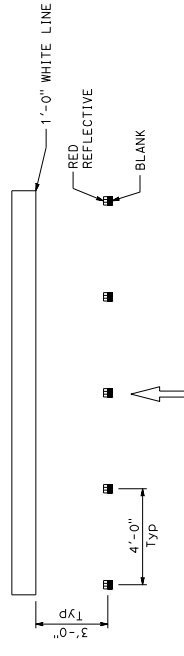

LIMIT LINE (STOP LINE) AT EXIT RAMP
 (Markers are recessed)

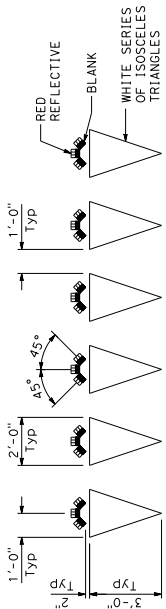

YIELD LINE AT EXIT RAMP
 (Markers are not recessed)

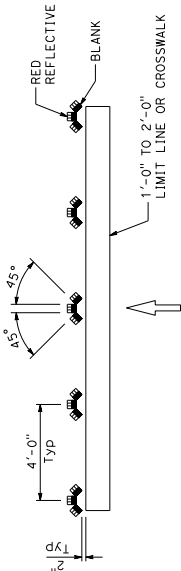

LIMIT LINE (STOP LINE) AT EXIT RAMP
 (Markers are not recessed)

NOTE:
 1. If there is crosswalk at the end of the exit ramp, place Type R markers in front of the first the wrong way vehicle that travels up the ramp with the red reflective side facing the intersection.



LIMIT LINE (STOP LINE)

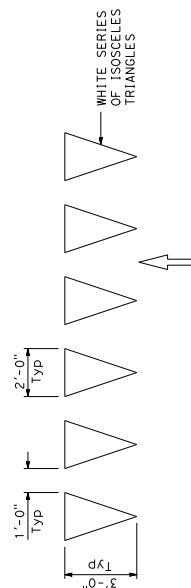

YIELD LINE

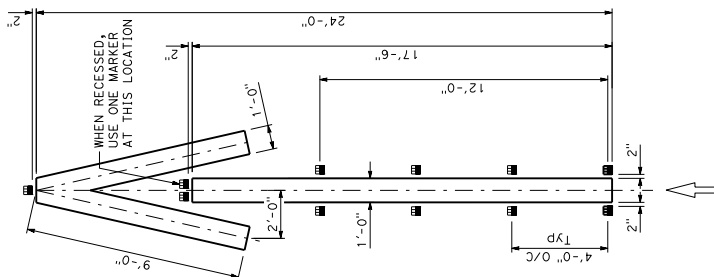

TYPE V ARROW AT EXIT RAMP
 A=33 f+2

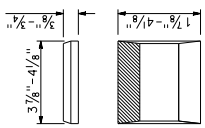

MARKER DETAILS
 TYPE R

RETROREFLECTIVE FACE ON BACKSIDE

STATE OF CALIFORNIA
 DEPARTMENT OF TRANSPORTATION
PAVEMENT MARKINGS
YIELD LINES, LIMIT LINES
AND WRONG WAY DETAILS
 NO SCALE

A 24G

Estimated Quantities - 2025 SLURRY SEAL / FOG SEAL

		Area ID														
		22	22	22	22	22	22	22	22	22	22	22	22	22	21	21
BID ITEM NO.	BID ITEM	UNIT	Barnhart Ave	Bret Ave	Calvert Dr	Johnson Ave	Judy Ave	Loree Ave	Medicus Ct	Morengo Dr	Runo Ct	Sterling Blvd	Sutton Park Pl	Brookgrove Ln	Ferngrove Dr	Hyde Ave
			Wunderlich to Sterling	Tilson to Loree	Tilson to Menhart	Newsom to Wunderlich	Tilson to Stevens Creek	Tantau to Stern	Sterling to End	Tuggle Pl to End	Sterling to End	Cynthia to Runo	Tantau to End	Shadygrove to Willowgrove	Shadygrove to Willowgrove	Bollinger to Shadygrove
1	Traffic Control	LS														
2	Crack Seal	LS	X	X	X	X	X	X	X	X	X	X	X	X	X	X
3	Fog Seal	SY	0	0	0	0	0	0	0	0	0	0	0	0	0	0
4	Type II Slurry Seal	SY	1836	1891	1763	1588	4045	1481	538	1852	552	3646	706	3494	3420	4659
5	Install Blue RPM's @ Fire Hydrant	EA	0	2	1	0	3	0	0	0	0	1	0	1	1	2
6	12" White Crosswalk/Limit Line (Thermo)	LF	50	25	25	25	50	100	25	0	25	110	25	0	0	50
7	12" Yellow Crosswalk	LF	0	0	0	0	0	0	0	0	0	0	0	0	0	0
8	24" White (Thermo)	LF	0	0	0	0	0	0	0	0	0	0	0	0	0	0
9	24" Yellow (Thermo)	LF	0	0	0	0	0	0	0	0	0	0	0	120	120	360
10	Striping Detail 22	LF	0	0	120	0	0	0	0	0	0	0	0	0	115	70
11	Striping Detail 38	LF	0	0	0	0	0	0	0	0	0	0	0	0	0	0
12	Arrow Type IV Left (Preformed Thermo)	EA	0	0	0	0	0	0	0	0	0	0	0	0	0	0
13	Arrow Type IV Right (Preformed Thermo)	EA	0	0	0	0	0	0	0	0	0	0	0	0	0	0
14	Arrow Type I 10' (Preformed Thermo)	EA	0	0	0	0	0	0	0	0	0	0	0	0	0	0
15	"25" Legend (Preformed Thermo)	EA	0	0	1	0	0	0	0	0	0	0	0	0	0	0
16	"Ahead Legend (Preformed)	EA	0	0	1	0	0	0	0	0	0	0	0	0	0	0
17	"Bump" Legend	EA	0	0	0	0	0	0	0	0	0	0	0	0	0	0
18	"STOP" Legend (Preformed Thermo)	EA	2	1	2	1	2	4	1	0	1	1	1	0	0	2
19	"SLOW SCHOOL XING" Legend (Preformed Thermo)	EA	0	0	0	0	0	0	0	0	0	0	0	0	0	2
20	Sharrow (Preformed Thermo)	EA	8	0	0	0	0	0	0	0	0	0	0	0	0	10
21	"SLOW PED XING" Legend (Preformed Thermo)	EA	0	0	0	0	0	0	0	0	0	0	0	0	0	0
22	"YIELD" Legend (Preformed Thermo)	EA	0	0	0	0	0	0	0	0	0	0	0	0	0	0
23	YIELD LINE (Preformed Thermo)	EA	0	0	0	0	0	0	0	0	0	0	0	0	0	0
24	Green Bike Lane	SF	0	0	0	0	0	0	0	0	0	0	0	0	0	0
25	Bike Rider Symbol on Green	EA	0	0	0	0	0	0	0	0	0	0	0	0	0	0
26	Bike Rider Arrow on Green	EA	0	0	0	0	0	0	0	0	0	0	0	0	0	0
27	Parking Ts (Thermo)	EA	0	0	0	0	0	0	0	0	0	0	0	0	0	0

Estimated Quantities - 2025 SLURRY SEAL / FC

			Area ID												
			21	21	21	21	21	26	26	26	26	26	26	26	26
BID ITEM NO.	BID ITEM	UNIT	Muriel Ln	Shadgrove Ct	Shadygrove Dr	Willowgrove Ln	Auburn Ct	Auburn Dr	Baywood Ct	Baywood Dr	Colby Ave	Cypress Ct	Cypress Dr	Denison Ave	Deodara Dr
			Tantau to End	Shadygrove to End	Stendhal to Tantau	Ferngrove to Hyde	Auburn to End	Portal to End	Merritt to End	Merritt to Pear Tree	Wheaton to Merritt	Cypress to End	Merritt to End	Wheaton to Merritt	Merritt to End
1	Traffic Control	LS													
2	Crack Seal	LS	X	X	X	X	X	X	X	X	X	X	X	X	X
3	Fog Seal	SY	0	0	0	0	0	0	0	0	0	0	0	0	0
4	Type II Slurry Seal	SY	1452	1410	5047	1997	513	3661	753	4493	7738	487	2022	7571	2230
5	Install Blue RPM's @ Fire Hydrant	EA	1	0	2	1	0	1	0	2	3	0	2	3	0
6	12" White Crosswalk/Limit Line (Thermo)	LF	0	0	0	25	0	120	0	0	50	0	0	50	0
7	12" Yellow Crosswalk	LF	0	0	0	0	0	0	0	0	0	0	0	0	0
8	24" White (Thermo)	LF	0	0	0	0	0	0	0	0	0	0	0	0	0
9	24" Yellow (Thermo)	LF	0	0	0	160	0	0	0	0	0	0	0	0	0
10	Striping Detail 22	LF	0	0	0	110	0	0	0	520	0	0	0	0	0
11	Striping Detail 38	LF	0	0	0	0	0	0	0	0	0	0	0	0	0
12	Arrow Type IV Left (Preformed Thermo)	EA	0	0	0	0	0	0	0	0	0	0	0	0	0
13	Arrow Type IV Right (Preformed Thermo)	EA	0	0	0	0	0	0	0	0	0	0	0	0	0
14	Arrow Type I 10' (Preformed Thermo)	EA	0	0	0	0	0	0	0	0	0	0	0	0	0
15	"25" Legend (Preformed Thermo)	EA	0	0	0	0	0	0	0	0	0	0	0	0	0
16	"Ahead Legend (Preformed)	EA	0	0	0	0	0	0	0	0	0	0	0	0	0
17	"Bump" Legend	EA	0	0	0	0	0	0	0	0	0	0	0	0	0
18	"STOP" Legend (Preformed Thermo)	EA	0	0	1	0	0	1	0	0	2	0	0	2	0
19	"SLOW SCHOOL XING" Legend (Preformed Thermo)	EA	0	0	0	0	0	0	0	0	0	0	0	0	0
20	Sharrow (Preformed Thermo)	EA	0	0	0	0	0	0	0	0	0	0	0	0	0
21	"SLOW PED XING" Legend (Preformed Thermo)	EA	0	0	0	0	0	0	0	0	0	0	0	0	0
22	"YIELD" Legend (Preformed Thermo)	EA	0	0	0	0	0	0	0	0	0	0	0	0	0
23	YIELD LINE (Preformed Thermo)	EA	0	0	0	0	0	0	0	0	0	0	0	0	0
24	Green Bike Lane	SF	0	0	0	0	0	0	0	0	0	0	0	0	0
25	Bike Rider Symbol on Green	EA	0	0	0	0	0	0	0	0	0	0	0	0	0
26	Bike Rider Arrow on Green	EA	0	0	0	0	0	0	0	0	0	0	0	0	0
27	Parking Ts (Thermo)	EA	0	0	0	0	0	0	0	0	0	0	0	0	0

Estimated Quantities - 2025 SLURRY SEAL / FC

Slurry Seal / Crack Seal

Area ID 26 20 20 20 20 19 19 19 19 27 27 27 27

BID ITEM NO.	BID ITEM	UNIT	Twilight Ct	Avocado PI	Bixby Dr	Cold Harbor Ave	Wintergreen Dr	John Dr	Lindenbrook Dr	West Estates Dr	Willowbrook Way	Cedar Tree Ct	Cedar Tree Ln	Forest Ave	Lazaneo Dr
			Blaney to End	Bixby to End	Portal to Cold Harbor	Vicksburg to Bixby	Cold Harbor to Portal	E Estates to Blaney	E Estates to Blaney	Lindenbrook to Estates	Lindenbrook to End	Cedar Tree to End	Orange Tree to Blaney	Vista to End	De Anza to Vista
1	Traffic Control	LS													
2	Crack Seal	LS	X	X	X	X	X	X	X	X	X	X	X	X	X
3	Fog Seal	SY	0	0	0	0	0	0	0	0	0	0	0	0	0
4	Type II Slurry Seal	SY	1585	937	2635	4210	1872	3106	3506	4019	1470	807	2288	1830	5283
5	Install Blue RPM's @ Fire Hydrant	EA	0	0	1	2	1	1	2	2	0	0	3	0	2
6	12" White Crosswalk/Limit Line (Thermo)	LF	25	0	0	0	25	120	25	0	0	0	110	25	325
7	12" Yellow Crosswalk	LF	0	0	0	0	0	0	0	0	0	0	0	0	0
8	24" White (Thermo)	LF	0	0	0	0	0	0	0	0	0	0	0	0	0
9	24" Yellow (Thermo)	LF	120	0	0	0	0	0	0	0	0	0	0	120	0
10	Striping Detail 22	LF	0	0	0	140	0	0	0	420	0	0	0	0	140
11	Striping Detail 38	LF	0	0	0	0	0	0	0	0	0	0	0	0	120
12	Arrow Type IV Left (Preformed Thermo)	EA	0	0	0	0	0	0	0	0	0	0	0	0	2
13	Arrow Type IV Right (Preformed Thermo)	EA	0	0	0	0	0	0	0	0	0	0	0	0	2
14	Arrow Type I 10' (Preformed Thermo)	EA	0	0	0	0	0	0	0	0	0	0	0	0	1
15	"25" Legend (Preformed Thermo)	EA	0	0	0	0	0	1	0	0	0	0	1	0	0
16	"Ahead Legend (Preformed)	EA	0	0	0	0	0	0	0	0	0	0	0	0	0
17	"Bump" Legend	EA	0	0	0	0	0	0	0	0	0	0	0	0	4
18	"STOP" Legend (Preformed Thermo)	EA	1	0	0	0	1	1	1	0	0	0	1	1	1
19	"SLOW SCHOOL XING" Legend (Preformed Thermo)	EA	0	0	0	0	0	0	0	0	0	0	0	0	0
20	Sharrow (Preformed Thermo)	EA	0	0	0	4	3	0	0	0	0	0	0	0	0
21	"SLOW PED XING" Legend (Preformed Thermo)	EA	0	0	0	0	0	0	0	0	0	0	0	0	0
22	"YIELD" Legend (Preformed Thermo)	EA	0	0	0	0	0	0	0	0	0	0	0	0	0
23	YIELD LINE (Preformed Thermo)	EA	0	0	0	0	0	0	0	0	0	0	0	0	0
24	Green Bike Lane	SF	0	0	0	0	0	0	0	0	0	0	0	0	0
25	Bike Rider Symbol on Green	EA	0	0	0	0	0	0	0	0	0	0	0	0	0
26	Bike Rider Arrow on Green	EA	0	0	0	0	0	0	0	0	0	0	0	0	0
27	Parking Ts (Thermo)	EA	0	0	0	0	0	0	0	0	0	0	0	0	0

Estimated Quantities - 2025 SLURRY SEAL / FC

			Area ID													
			27	27	27	27	17	17	17	17	17	17	17	17	18	18
BID ITEM NO.	BID ITEM	UNIT	Orange Tree Ln	Toni Ct	Villa De Anza	Vista Dr	Brittany Ct	Las Ondas Ct	Las Ondas Way	Normandy Ct	Pacifica Dr	Somerset Ct	Somerset Dr	Somerset Dr	Antoinette Dr	Farallone Dr
			Merritt to Cedar Tree	Forest to End	Lucille to Blaney	Stevens Creek to Lazaneo	Las Ondas to End	Las Ondas to End	Somerset to Pacifica	Somerset to End	Farallone to Torre	Somerset to End	Farallone to Las Ondas	Las Ondas to Blaney	Ckay to Cliifden	John to Pacifica
1	Traffic Control	LS														
2	Crack Seal	LS	X	X	X	X	X	X	X	X	X	X	X	X	X	X
3	Fog Seal	SY	0	0	0	0	0	0	0	0	0	0	0	0	0	0
4	Type II Slurry Seal	SY	1664	804	1665	5242	1123	1086	2038	1029	3224	1029	3266	1456	1005	3894
5	Install Blue RPM's @ Fire Hydrant	EA	1	0	1	0	0	0	2	0	0	0	1	1	1	2
6	12" White Crosswalk/Limit Line (Thermo)	LF	0	0	1	250	0	0	25	0	20	0	0	25	0	60
7	12" Yellow Crosswalk	LF	110	0	55	120	0	0	0	0	0	0	0	0	0	0
8	24" White (Thermo)	LF	0	0	0	110	0	0	0	0	0	0	0	0	0	0
9	24" Yellow (Thermo)	LF	0	120	0	0	0	0	0	0	110	0	0	0	0	240
10	Striping Detail 22	LF	0	0	0	115	0	0	0	0	540	0	0	0	280	150
11	Striping Detail 38	LF	0	0	0	0	0	0	0	0	0	0	0	0	0	0
12	Arrow Type IV Left (Preformed Thermo)	EA	0	0	0	0	0	0	0	0	0	0	0	0	0	0
13	Arrow Type IV Right (Preformed Thermo)	EA	0	0	0	2	0	0	0	0	0	0	0	0	0	0
14	Arrow Type I 10' (Preformed Thermo)	EA	0	0	0	0	0	0	0	0	0	0	0	0	0	0
15	"25" Legend (Preformed Thermo)	EA	0	0	0	1	0	0	0	0	0	0	0	0	0	0
16	"Ahead Legend (Preformed)	EA	0	0	0	0	0	0	0	0	0	0	0	0	0	0
17	"Bump" Legend	EA	0	0	0	4	0	0	0	0	0	0	0	0	0	0
18	"STOP" Legend (Preformed Thermo)	EA	1	0	2	0	0	0	0	0	1	0	0	1	0	0
19	"SLOW SCHOOL XING" Legend (Preformed Thermo)	EA	0	0	0	0	0	0	0	0	0	0	0	0	0	2
20	Sharrow (Preformed Thermo)	EA	0	0	0	12	0	0	0	0	4	0	0	0	0	2
21	"SLOW PED XING" Legend (Preformed Thermo)	EA	0	0	0	0	0	0	0	0	1	0	0	0	0	0
22	"YIELD" Legend (Preformed Thermo)	EA	0	0	0	0	0	0	1	0	0	0	0	0	0	0
23	YIELD LINE (Preformed Thermo)	EA	0	3	0	0	0	0	0	0	0	0	0	0	0	0
24	Green Bike Lane	SF	0	0	0	30	0	0	0	0	0	0	0	0	0	0
25	Bike Rider Symbol on Green	EA	0	0	0	1	0	0	0	0	0	0	0	0	0	0
26	Bike Rider Arrow on Green	EA	0	0	0	1	0	0	0	0	0	0	0	0	0	0
27	Parking Ts (Thermo)	EA	0	0	0	0	0	0	0	0	14	0	0	0	0	0

Estimated Quantities - 2025 SLURRY SEAL / FC

		Area ID					Fog Seal								
			18	18	18	18	1	1	2	2	2	2	2	2	
BID ITEM NO.	BID ITEM	UNIT	La Roda Dr	Lynton Ct	Michael Ct	Whitney Way	Grapnel PI	Pebble PI	Acadia Ct	Dunbar Dr	Fargo Dr	Elenda Dr	Glencoe Dr	Glencoe Dr	
			Suisun to End	Farallone to End	Cliffden to End	Pacifica to Clay	Amulet to End	Amulet to End	Beardon to End	Glencoe Dr to E End	Glencoe Dr to E End	Glencoe to End	Elenda to Hanford	Fargo to Greenleaf	
1	Traffic Control	LS						-	-	-	-	-	-	-	
2	Crack Seal	LS	X	X	X	X	0	0	0	0	0	0	0	0	
3	Fog Seal	SY	0	0	0	0	1100	1173	1698	5628	5685	2207	2612	2814	
4	Type II Slurry Seal	SY	5416	789	462	2654	0	0	0	0	0	0	0	0	
5	Install Blue RPM's @ Fire Hydrant	EA	2	0	0	1	0	0	0	0	0	0	0	0	
6	12" White Crosswalk/Limit Line (Thermo)	LF	25	0	0	25	0	0	0	0	0	0	0	0	
7	12" Yellow Crosswalk	LF	120	0	0	0	0	0	0	0	0	0	0	0	
8	24" White (Thermo)	LF	0	0	0	0	0	0	0	0	0	0	0	0	
9	24" Yellow (Thermo)	LF	120	0	0	0	0	0	0	0	0	0	0	0	
10	Striping Detail 22	LF	0	0	0	190	0	0	0	0	0	0	0	0	
11	Striping Detail 38	LF	0	0	0	0	0	0	0	0	0	0	0	0	
12	Arrow Type IV Left (Preformed Thermo)	EA	0	0	0	0	0	0	0	0	0	0	0	0	
13	Arrow Type IV Right (Preformed Thermo)	EA	0	0	0	0	0	0	0	0	0	0	0	0	
14	Arrow Type I 10' (Preformed Thermo)	EA	0	0	0	0	0	0	0	0	0	0	0	0	
15	"25" Legend (Preformed Thermo)	EA	0	0	0	0	0	0	0	0	0	0	0	0	
16	"Ahead Legend (Preformed)	EA	0	0	0	0	0	0	0	0	0	0	0	0	
17	"Bump" Legend	EA	0	0	0	0	0	0	0	0	0	0	0	0	
18	"STOP" Legend (Preformed Thermo)	EA	0	0	0	1	0	0	0	0	0	0	0	0	
19	"SLOW SCHOOL XING" Legend (Preformed Thermo)	EA	0	0	0	0	0	0	0	0	0	0	0	0	
20	Sharrow (Preformed Thermo)	EA	0	0	0	0	0	0	0	0	0	0	0	0	
21	"SLOW PED XING" Legend (Preformed Thermo)	EA	0	0	0	0	0	0	0	0	0	0	0	0	
22	"YIELD" Legend (Preformed Thermo)	EA	1	0	0	0	0	0	0	0	0	0	0	0	
23	YIELD LINE (Preformed Thermo)	EA	6	0	0	0	0	0	0	0	0	0	0	0	
24	Green Bike Lane	SF	0	0	0	0	0	0	0	0	0	0	0	0	
25	Bike Rider Symbol on Green	EA	0	0	0	0	0	0	0	0	0	0	0	0	
26	Bike Rider Arrow on Green	EA	0	0	0	0	0	0	0	0	0	0	0	0	
27	Parking Ts (Thermo)	EA	0	0	0	0	0	0	0	0	0	0	0	0	

Estimated Quantities - 2025 SLURRY SEAL / FC

		Area ID	2	9	9	15	15	15	15	15	15	16
BID ITEM NO.	BID ITEM	UNIT	Hanford Dr	Moltzen Dr	Ruppell Pl	Blossom Ln	Felton Way	John Way	Jollyman Ln	Lonna Ln	Orline Ct	Paradise Dr
			Glencoe to E End	Ruppell to Candlelight	Kingsburry to End	Felton to End	Kirwin to McClellan	Kirwin to McClellan	Stelling to End	Kirwin to McClellan	Jollyman to End	Terry to Cheryl
1	Traffic Control	LS	-	-	-	-	-	-	-	-	-	-
2	Crack Seal	LS	0	0	0	0	0	0	0	0	0	0
3	Fog Seal	SY	5650	1587	2254	1190	3255	3074	1710	3074	1100	2940
4	Type II Slurry Seal	SY	0	0	0	0	0	0	0	0	0	0
5	Install Blue RPM's @ Fire Hydrant	EA	0	0	0	0	0	0	0	0	0	0
6	12" White Crosswalk/Limit Line (Thermo)	LF	0	0	0	0	0	0	0	0	0	0
7	12" Yellow Crosswalk	LF	0	0	0	0	0	0	0	0	0	0
8	24" White (Thermo)	LF	0	0	0	0	0	0	0	0	0	0
9	24" Yellow (Thermo)	LF	0	0	0	0	0	0	0	0	0	0
10	Striping Detail 22	LF	0	0	0	0	0	0	0	0	0	0
11	Striping Detail 38	LF	0	0	0	0	0	0	0	0	0	0
12	Arrow Type IV Left (Preformed Thermo)	EA	0	0	0	0	0	0	0	0	0	0
13	Arrow Type IV Right (Preformed Thermo)	EA	0	0	0	0	0	0	0	0	0	0
14	Arrow Type I 10' (Preformed Thermo)	EA	0	0	0	0	0	0	0	0	0	0
15	"25" Legend (Preformed Thermo)	EA	0	0	0	0	0	0	0	0	0	0
16	"Ahead Legend (Preformed)	EA	0	0	0	0	0	0	0	0	0	0
17	"Bump" Legend	EA	0	0	0	0	0	0	0	0	0	0
18	"STOP" Legend (Preformed Thermo)	EA	0	0	0	0	0	0	0	0	0	0
19	"SLOW SCHOOL XING" Legend (Preformed Thermo)	EA	0	0	0	0	0	0	0	0	0	0
20	Sharrow (Preformed Thermo)	EA	0	0	0	0	0	0	0	0	0	0
21	"SLOW PED XING" Legend (Preformed Thermo)	EA	0	0	0	0	0	0	0	0	0	0
22	"YIELD" Legend (Preformed Thermo)	EA	0	0	0	0	0	0	0	0	0	0
23	YIELD LINE (Preformed Thermo)	EA	0	0	0	0	0	0	0	0	0	0
24	Green Bike Lane	SF	0	0	0	0	0	0	0	0	0	0
25	Bike Rider Symbol on Green	EA	0	0	0	0	0	0	0	0	0	0
26	Bike Rider Arrow on Green	EA	0	0	0	0	0	0	0	0	0	0
27	Parking Ts (Thermo)	EA	0	0	0	0	0	0	0	0	0	0

Estimated Quantities - 2025 SLURRY SEAL / FC

Fog Seal / Crack Seal

Area ID 16 19 19 19 19 19 19 19 20 21

BID ITEM NO.	BID ITEM	UNIT	Rodrigues Ave	E Estates Dr	La Mar Ct	La Mar Dr	Landsdale Ave	Lindsay Ave	Malvern Ct	Oakville Ave	Greenwood Ct	Greenwood Dr
			Western to De Anza	John Dr to Estates Dr	E Estates to E End	E Estates to Blaney	Oakville to La Mar	La Mar to Oakville	La Mar to End	Glenview to La Mar	Miller to End	Miller to End
1	Traffic Control	LS	-	-	-	-	-	-	-	-	-	-
2	Crack Seal	LS	0	0	0	0	0	0	0	0	0	0
3	Fog Seal	SY	5482	4394	815	7518	2893	2091	550	3845	1549	2289
4	Type II Slurry Seal	SY	0	0	0	0	0	0	0	0	0	0
5	Install Blue RPM's @ Fire Hydrant	EA	0	0	0	0	0	0	0	0	0	0
6	12" White Crosswalk/Limit Line (Thermo)	LF	0	0	0	0	0	0	0	0	0	0
7	12" Yellow Crosswalk	LF	0	0	0	0	0	0	0	0	0	0
8	24" White (Thermo)	LF	0	0	0	0	0	0	0	0	0	0
9	24" Yellow (Thermo)	LF	0	0	0	0	0	0	0	0	0	0
10	Striping Detail 22	LF	0	0	0	0	0	0	0	0	0	0
11	Striping Detail 38	LF	0	0	0	0	0	0	0	0	0	0
12	Arrow Type IV Left (Preformed Thermo)	EA	0	0	0	0	0	0	0	0	0	0
13	Arrow Type IV Right (Preformed Thermo)	EA	0	0	0	0	0	0	0	0	0	0
14	Arrow Type I 10' (Preformed Thermo)	EA	0	0	0	0	0	0	0	0	0	0
15	"25" Legend (Preformed Thermo)	EA	0	0	0	0	0	0	0	0	0	0
16	"Ahead Legend (Preformed)	EA	0	0	0	0	0	0	0	0	0	0
17	"Bump" Legend	EA	0	0	0	0	0	0	0	0	0	0
18	"STOP" Legend (Preformed Thermo)	EA	0	0	0	0	0	0	0	0	0	0
19	"SLOW SCHOOL XING" Legend (Preformed Thermo)	EA	0	0	0	0	0	0	0	0	0	0
20	Sharrow (Preformed Thermo)	EA	0	0	0	0	0	0	0	0	0	0
21	"SLOW PED XING" Legend (Preformed Thermo)	EA	0	0	0	0	0	0	0	0	0	0
22	"YIELD" Legend (Preformed Thermo)	EA	0	0	0	0	0	0	0	0	0	0
23	YIELD LINE (Preformed Thermo)	EA	0	0	0	0	0	0	0	0	0	0
24	Green Bike Lane	SF	0	0	0	0	0	0	0	0	0	0
25	Bike Rider Symbol on Green	EA	0	0	0	0	0	0	0	0	0	0
26	Bike Rider Arrow on Green	EA	0	0	0	0	0	0	0	0	0	0
27	Parking Ts (Thermo)	EA	0	0	0	0	0	0	0	0	0	0

Estimated Quantities - 2025 SLURRY SEAL / FC

		Area ID	21	26	26	26	31	31	32	32	35	35
BID ITEM NO.	BID ITEM	UNIT	Leola Ct	Drake Ct	Drake Dr	Portal Ave	Madera Dr	Mann Dr	Creston Dr	Stonydale	Cordova Rd	Mercedes Rd
			Greenwood to End	Drake to End	Portal to Auburn	Stevens Creek to N End	Phar Lap to N End	Stevens Creek to Phar Lap	150' N/O Rivercrest to End	Creston to End	Santa Lucia to End	Cordova to End
1	Traffic Control	LS	-	-	-	-	-	-	-	-	-	-
2	Crack Seal	LS	0	0	0	0	0	0	0	0	0	0
3	Fog Seal	SY	874	704	3793	14028	5900	11687	3763	3780	3267	1785
4	Type II Slurry Seal	SY	0	0	0	0	0	0	0	0	0	0
5	Install Blue RPM's @ Fire Hydrant	EA	0	0	0	0	0	0	0	0	0	0
6	12" White Crosswalk/Limit Line (Thermo)	LF	0	0	0	0	0	0	0	0	0	0
7	12" Yellow Crosswalk	LF	0	0	0	0	0	0	0	0	0	0
8	24" White (Thermo)	LF	0	0	0	0	0	0	0	0	0	0
9	24" Yellow (Thermo)	LF	0	0	0	0	0	0	0	0	0	0
10	Striping Detail 22	LF	0	0	0	0	0	0	0	0	0	0
11	Striping Detail 38	LF	0	0	0	0	0	0	0	0	0	0
12	Arrow Type IV Left (Preformed Thermo)	EA	0	0	0	0	0	0	0	0	0	0
13	Arrow Type IV Right (Preformed Thermo)	EA	0	0	0	0	0	0	0	0	0	0
14	Arrow Type I 10' (Preformed Thermo)	EA	0	0	0	0	0	0	0	0	0	0
15	"25" Legend (Preformed Thermo)	EA	0	0	0	0	0	0	0	0	0	0
16	"Ahead Legend (Preformed)	EA	0	0	0	0	0	0	0	0	0	0
17	"Bump" Legend	EA	0	0	0	0	0	0	0	0	0	0
18	"STOP" Legend (Preformed Thermo)	EA	0	0	0	0	0	0	0	0	0	0
19	"SLOW SCHOOL XING" Legend (Preformed Thermo)	EA	0	0	0	0	0	0	0	0	0	0
20	Sharrow (Preformed Thermo)	EA	0	0	0	0	0	0	0	0	0	0
21	"SLOW PED XING" Legend (Preformed Thermo)	EA	0	0	0	0	0	0	0	0	0	0
22	"YIELD" Legend (Preformed Thermo)	EA	0	0	0	0	0	0	0	0	0	0
23	YIELD LINE (Preformed Thermo)	EA	0	0	0	0	0	0	0	0	0	0
24	Green Bike Lane	SF	0	0	0	0	0	0	0	0	0	0
25	Bike Rider Symbol on Green	EA	0	0	0	0	0	0	0	0	0	0
26	Bike Rider Arrow on Green	EA	0	0	0	0	0	0	0	0	0	0
27	Parking Ts (Thermo)	EA	0	0	0	0	0	0	0	0	0	0

Estimated Quantities - 2025 SLURRY SEAL / FC

Area ID 36 36 36 36 36 36 36 37 37 39

BID ITEM NO.	BID ITEM	UNIT	Alicia Ct	Degas Ct	El Prado Way	Krista Ct	Medina Ln	Standing Oak Ct	Voss Ave	Poppy Dr	Salem Ave	Blackoak Way
			Alcalde to End	Medina to End	Voss to Medina	Voss to End	El Prado to Lockwood	Voss to End	Krista Ct to End	Foothill to End	Anthony to Foothill	Sycamore Dr to End
1	Traffic Control	LS	-	-	-	-	-	-	-	-	-	-
2	Crack Seal	LS	0	0	0	0	0	0	0	0	0	0
3	Fog Seal	SY	936	666	1983	614	2835	903	3830	1563	3570	1773
4	Type II Slurry Seal	SY	0	0	0	0	0	0	0	0	0	0
5	Install Blue RPM's @ Fire Hydrant	EA	0	0	0	0	0	0	0	0	0	0
6	12" White Crosswalk/Limit Line (Thermo)	LF	0	0	0	0	0	0	0	0	0	0
7	12" Yellow Crosswalk	LF	0	0	0	0	0	0	0	0	0	0
8	24" White (Thermo)	LF	0	0	0	0	0	0	0	0	0	0
9	24" Yellow (Thermo)	LF	0	0	0	0	0	0	0	0	0	0
10	Striping Detail 22	LF	0	0	0	0	0	0	0	0	0	0
11	Striping Detail 38	LF	0	0	0	0	0	0	0	0	0	0
12	Arrow Type IV Left (Preformed Thermo)	EA	0	0	0	0	0	0	0	0	0	0
13	Arrow Type IV Right (Preformed Thermo)	EA	0	0	0	0	0	0	0	0	0	0
14	Arrow Type I 10' (Preformed Thermo)	EA	0	0	0	0	0	0	0	0	0	0
15	"25" Legend (Preformed Thermo)	EA	0	0	0	0	0	0	0	0	0	0
16	"Ahead Legend (Preformed)	EA	0	0	0	0	0	0	0	0	0	0
17	"Bump" Legend	EA	0	0	0	0	0	0	0	0	0	0
18	"STOP" Legend (Preformed Thermo)	EA	0	0	0	0	0	0	0	0	0	0
19	"SLOW SCHOOL XING" Legend (Preformed Thermo)	EA	0	0	0	0	0	0	0	0	0	0
20	Sharrow (Preformed Thermo)	EA	0	0	0	0	0	0	0	0	0	0
21	"SLOW PED XING" Legend (Preformed Thermo)	EA	0	0	0	0	0	0	0	0	0	0
22	"YIELD" Legend (Preformed Thermo)	EA	0	0	0	0	0	0	0	0	0	0
23	YIELD LINE (Preformed Thermo)	EA	0	0	0	0	0	0	0	0	0	0
24	Green Bike Lane	SF	0	0	0	0	0	0	0	0	0	0
25	Bike Rider Symbol on Green	EA	0	0	0	0	0	0	0	0	0	0
26	Bike Rider Arrow on Green	EA	0	0	0	0	0	0	0	0	0	0
27	Parking Ts (Thermo)	EA	0	0	0	0	0	0	0	0	0	0

Estimated Quantities - 2025 SLURRY SEAL / FC

Area ID 39 39

BID ITEM NO.	BID ITEM	UNIT	Juniper Ct	Sycamore Dr	TOTAL ESTIMATED QUANTITY
			Oak Valley Rd to End	Oak Valley Rd to Gate	
1	Traffic Control	LS	-	-	1
2	Crack Seal	LS	0	0	1
3	Fog Seal	SY	1295	2733	152,461
4	Type II Slurry Seal	SY	0	0	142,240
5	Install Blue RPM's @ Fire Hydrant	EA	0	0	52
6	12" White Crosswalk/Limit Line (Thermo)	LF	0	0	1841
7	12" Yellow Crosswalk	LF	0	0	405
8	24" White (Thermo)	LF	0	0	110
9	24" Yellow (Thermo)	LF	0	0	1590
10	Striping Detail 22	LF	0	0	2910
11	Striping Detail 38	LF	0	0	120
12	Arrow Type IV Left (Preformed Thermo)	EA	0	0	2
13	Arrow Type IV Right (Preformed Thermo)	EA	0	0	4
14	Arrow Type I 10' (Preformed Thermo)	EA	0	0	1
15	"25" Legend (Preformed Thermo)	EA	0	0	4
16	"Ahead Legend (Preformed)	EA	0	0	1
17	"Bump" Legend	EA	0	0	8
18	"STOP" Legend (Preformed Thermo)	EA	0	0	37
19	"SLOW SCHOOL XING" Legend (Preformed Thermo)	EA	0	0	4
20	Sharrow (Preformed Thermo)	EA	0	0	43
21	"SLOW PED XING" Legend (Preformed Thermo)	EA	0	0	1
22	"YIELD" Legend (Preformed Thermo)	EA	0	0	2
23	YIELD LINE (Preformed Thermo)	EA	0	0	9
24	Green Bike Lane	SF	0	0	30
25	Bike Rider Symbol on Green	EA	0	0	1
26	Bike Rider Arrow on Green	EA	0	0	1
27	Parking Ts (Thermo)	EA	0	0	14

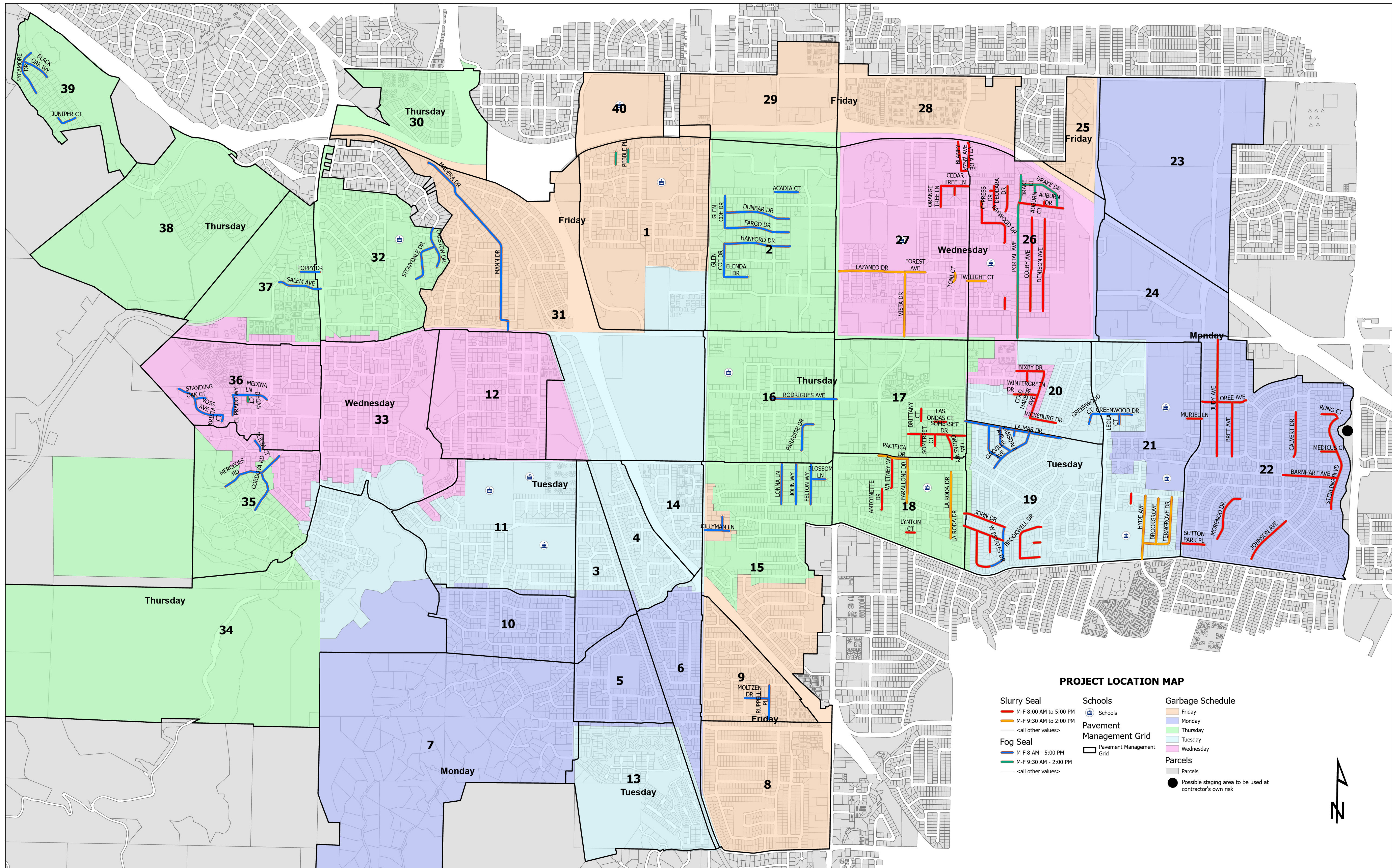

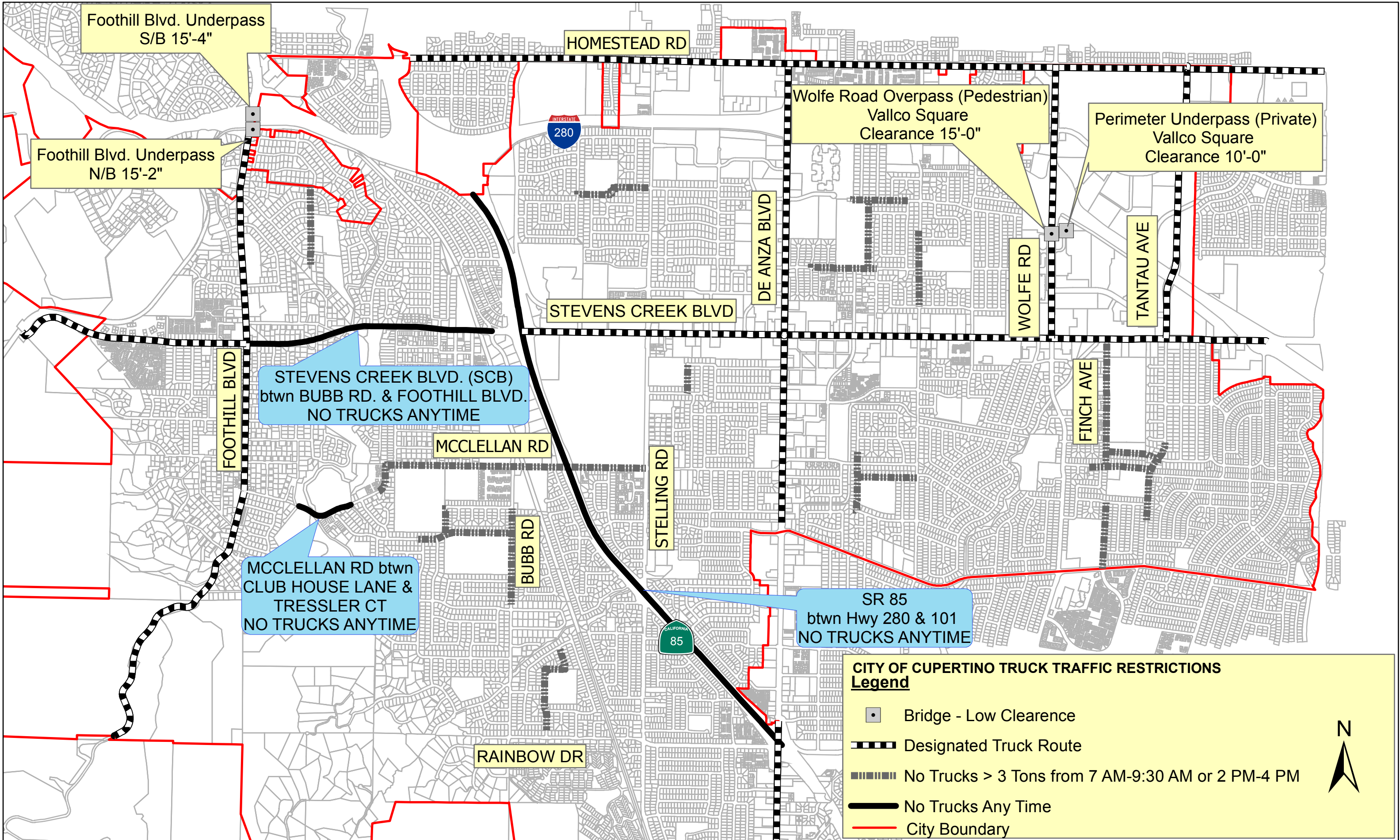

CITY OF CUPERTINO TRUCK TRAFFIC RESTRICTIONS Legend

- Bridge - Low Clearance
- ▬ Designated Truck Route
- ▬ No Trucks > 3 Tons from 7 AM-9:30 AM or 2 PM-4 PM
- ▬ No Trucks Any Time
- ▬ City Boundary

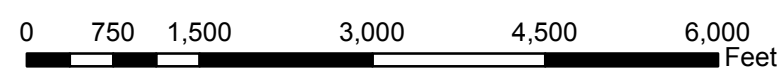

All TRUCKS SHALL COMPLY WITH SECTION 11.32 OF THE CUPERTINO MUNICIPAL CODE



Academic Calendar

2024-2025 SCHOOL CALENDARS

2025-2026 SCHOOL CALENDARS

2026-2027 SCHOOL CALENDARS

All Schools (Except Murdock-Portal)

Board Approved: December 7, 2023

Teachers Return	Aug. 12, 2024
Students Return	Aug. 15, 2024
Holiday - Labor Day	Sept. 2, 2024
Staff Learning Day	Sept. 20, 2024
Minimum Day	Sept. 27, 2024
Staff Learning Day	Nov. 1, 2024
Minimum Day	Nov. 8, 2024
Holiday - Veterans' Day	Nov. 11, 2024
Thanksgiving Recess	Nov. 25-29, 2024
Winter Recess	Dec. 23, 2024 - Jan. 3, 2025
Students Return	Jan. 6, 2025
Holiday - Martin Luther King Day	Jan. 20, 2025
Mid-Year Recess	Feb. 17-21, 2025
Minimum Day	March 14, 2025
Spring Recess	April 14-18, 2025
Staff Learning Day	May 5, 2025
Holiday - Memorial Day Observed	May 26, 2025
Minimum Day	June 5, 2025
Last Day of School/Minimum Day	June 6, 2025

Murdock-Portal Elementary School

Board Approved: December 7, 2023

Teachers Return	July 29, 2024
-----------------	---------------

Students Return	Aug. 1, 2024
Holiday - Labor Day	Sept. 2, 2024
Staff Learning Day	Sept. 20, 2024
Minimum Day	Sept. 27, 2024
Fall Recess	Sept. 30 - Oct.11, 2024
Staff Learning Day	Nov. 1, 2024
Minimum Day	Nov. 8, 2024
Holiday - Veterans' Day	Nov. 11, 2024
Thanksgiving Recess	Nov. 25-29, 2024
Winter Recess	Dec. 23, 2024 - Jan 3, 2025
Students Return	Jan. 6, 2025
Holiday - Martin Luther King Day	Jan. 20, 2025
Mid-Year Recess	Feb. 17-21, 2025
Minimum Day	March 14, 2025
Spring Recess	April 7-18, 2025
Staff Learning Day	May 5, 2025
Holiday - Memorial Day Observed	May 26, 2025
Minimum Day	June 12, 2025
Last Day of School/Minimum Day	June 13, 2025

STREET NAME	FROM	TO	TREATMENT	LANE CLOSURE HOURS
ALDERBROOK WY	ALDERBROOK	END	CRACK SEAL / SLURRY SEAL	M-F 8:00 AM to 5:00 PM
ANTOINETTE DR	CLAY	CLIFDEN	CRACK SEAL / SLURRY SEAL	M-F 8:00 AM to 5:00 PM
AUBURN CT	AUBURN	END	CRACK SEAL / SLURRY SEAL	M-F 8:00 AM to 5:00 PM
AUBURN DR	PORTAL	END	CRACK SEAL / SLURRY SEAL	M-F 8:00 AM to 5:00 PM
AVOCADO PL	BIXBY	END	CRACK SEAL / SLURRY SEAL	M-F 8:00 AM to 5:00 PM
BARNHART AVE	WUNDERLICH	JOHNSON	CRACK SEAL / SLURRY SEAL	M-F 8:00 AM to 5:00 PM
BARNHART AVE	JOHNSON	STERLING	CRACK SEAL / SLURRY SEAL	M-F 8:00 AM to 5:00 PM
BAYWOOD CT	MERRITT	END	CRACK SEAL / SLURRY SEAL	M-F 8:00 AM to 5:00 PM
BAYWOOD DR	MERRITT	PEAR TREE	CRACK SEAL / SLURRY SEAL	M-F 8:00 AM to 5:00 PM
BIXBY DR	SOUTH POPLAR	COLD HARBOR	CRACK SEAL / SLURRY SEAL	M-F 8:00 AM to 5:00 PM
BLANEY AVE	LUCILLE	OLIVEWOOD	CRACK SEAL / SLURRY SEAL	M-F 8:00 AM to 5:00 PM
BLANEY AVE	OLIVEWOOD	250' S/O OLIVEWOOD	CRACK SEAL / SLURRY SEAL	M-F 8:00 AM to 5:00 PM
BRET AVE	TILSON	LOREE	CRACK SEAL / SLURRY SEAL	M-F 8:00 AM to 5:00 PM
BRITTANY CT	LAS ONDAS	END	CRACK SEAL / SLURRY SEAL	M-F 8:00 AM to 5:00 PM
BROOKGROVE	SHADYGROVE	WILLOWGROVE	CRACK SEAL / SLURRY SEAL	M-F 9:30 AM to 2:00 PM
BROOKWELL DR	ALDERBROOK	ALDERBROOK	CRACK SEAL / SLURRY SEAL	M-F 8:00 AM to 5:00 PM
CALVERT DR	TILSON	MENHART	CRACK SEAL / SLURRY SEAL	M-F 8:00 AM to 5:00 PM
CEDAR TREE CT	CEDAR TREE	END	CRACK SEAL / SLURRY SEAL	M-F 8:00 AM to 5:00 PM
CEDAR TREE LN	ORANGE TREE	BLANEY	CRACK SEAL / SLURRY SEAL	M-F 8:00 AM to 5:00 PM
COLBY AVE	WHEATON	MERRITT	CRACK SEAL / SLURRY SEAL	M-F 8:00 AM to 5:00 PM
COLD HARBOR AVE	VICKSBURG	BIXBY	CRACK SEAL / SLURRY SEAL	M-F 8:00 AM to 5:00 PM
CYPRESS CT	CYPRESS	END	CRACK SEAL / SLURRY SEAL	M-F 8:00 AM to 5:00 PM
CYPRESS DR	MERRITT	END	CRACK SEAL / SLURRY SEAL	M-F 8:00 AM to 5:00 PM
DENISON AVE	WHEATON	MERRITT	CRACK SEAL / SLURRY SEAL	M-F 8:00 AM to 5:00 PM
DEODARA DR	MERRITT	END	CRACK SEAL / SLURRY SEAL	M-F 8:00 AM to 5:00 PM
FARALLONE DR	JOHN	PACIFICA	CRACK SEAL / SLURRY SEAL	M-F 9:30 AM to 2:00 PM
FERNGROVE DR	SHADYGROVE	WILLOWGROVE	CRACK SEAL / SLURRY SEAL	M-F 9:30 AM to 2:00 PM
FOREST AVE	VISTA	END (E)	CRACK SEAL / SLURRY SEAL	M-F 9:30 AM to 2:00 PM
HYDE AVE	BOLLINGER	SHADYGROVE	CRACK SEAL / SLURRY SEAL	M-F 9:30 AM to 2:00 PM
JOHN DR	E ESTATES	BLANEY	CRACK SEAL / SLURRY SEAL	M-F 8:00 AM to 5:00 PM
JOHNSON AVE	NEWSOM	WUNDERLICH	CRACK SEAL / SLURRY SEAL	M-F 8:00 AM to 5:00 PM
JUDY AVE	TILSON	LOREE	CRACK SEAL / SLURRY SEAL	M-F 8:00 AM to 5:00 PM
JUDY AVE	LOREE	STEVENS C	CRACK SEAL / SLURRY SEAL	M-F 8:00 AM to 5:00 PM
LA RODA DR	SUISUN	END	CRACK SEAL / SLURRY SEAL	M-F 9:30 AM to 2:00 PM
LAS ONDAS CT	LAS ONDAS	END	CRACK SEAL / SLURRY SEAL	M-F 8:00 AM to 5:00 PM
LAS ONDAS WY	SOMERSET	PACIFICA	CRACK SEAL / SLURRY SEAL	M-F 8:00 AM to 5:00 PM
LAZANEO DR	DE ANZA	VISTA	CRACK SEAL / SLURRY SEAL	M-F 9:30 AM to 2:00 PM
LINDENBROOK DR	E ESTATES	BLANEY	CRACK SEAL / SLURRY SEAL	M-F 8:00 AM to 5:00 PM
LOREE AVE	TANTAU	STERN	CRACK SEAL / SLURRY SEAL	M-F 8:00 AM to 5:00 PM
LYNTON CT	FARALLON	END	CRACK SEAL / SLURRY SEAL	M-F 8:00 AM to 5:00 PM
MC LAREN PL	WHEATON	END	CRACK SEAL / SLURRY SEAL	M-F 8:00 AM to 5:00 PM
MEDICUS CT	STERLING	END	CRACK SEAL / SLURRY SEAL	M-F 8:00 AM to 5:00 PM
MICHAEL CT	CLIFDEN	END	CRACK SEAL / SLURRY SEAL	M-F 8:00 AM to 5:00 PM

STREET NAME	FROM	TO	TREATMENT	LANE CLOSURE HOURS
MORENGO DR	TUGGLE PL	END	CRACK SEAL / SLURRY SEAL	M-F 8:00 AM to 5:00 PM
MURIEL LN	TANTAU	END	CRACK SEAL / SLURRY SEAL	M-F 8:00 AM to 5:00 PM
NORMANDY CT	SOMERSET	END	CRACK SEAL / SLURRY SEAL	M-F 8:00 AM to 5:00 PM
ORANGE TREE LN	MERRITT	CEDAR TR	CRACK SEAL / SLURRY SEAL	M-F 8:00 AM to 5:00 PM
PACIFICA DR	FARRALON	TORRE	CRACK SEAL / SLURRY SEAL	M-F 9:30 AM to 2:00 PM
RUNO CT	STERLING	END	CRACK SEAL / SLURRY SEAL	M-F 8:00 AM to 5:00 PM
SHADYGROVE CT	SHADYGRO	END	CRACK SEAL / SLURRY SEAL	M-F 8:00 AM to 5:00 PM
SOMERSET CT	SOMERSET	END	CRACK SEAL / SLURRY SEAL	M-F 8:00 AM to 5:00 PM
SOMERSET DR	FARALLON	LAS ONDA	CRACK SEAL / SLURRY SEAL	M-F 8:00 AM to 5:00 PM
SOMERSET DR	LAS ONDA	BLANEY	CRACK SEAL / SLURRY SEAL	M-F 8:00 AM to 5:00 PM
STERLING BLVD	CYNTHIA A	BARNHART	CRACK SEAL / SLURRY SEAL	M-F 8:00 AM to 5:00 PM
STERLING BLVD	BARNHART	RUNO	CRACK SEAL / SLURRY SEAL	M-F 8:00 AM to 5:00 PM
SUTTON PARK PL	TANTAU	END	CRACK SEAL / SLURRY SEAL	M-F 8:00 AM to 5:00 PM
TONI CT	FOREST	END	CRACK SEAL / SLURRY SEAL	M-F 9:30 AM to 2:00 PM
TWILIGHT CT	BLANEY	END	CRACK SEAL / SLURRY SEAL	M-F 9:30 AM to 2:00 PM
VICKSBURG DR	COLD HAR	E ESTATES	CRACK SEAL / SLURRY SEAL	M-F 8:00 AM to 5:00 PM
VILLA DE ANZA	LUCILLE	BLANEY	CRACK SEAL / SLURRY SEAL	M-F 8:00 AM to 5:00 PM
VISTA DR	STEVENS C	LAZANEO	CRACK SEAL / SLURRY SEAL	M-F 9:30 AM to 2:00 PM
W ESTATES DR	LINDENBR	ESTATES D	CRACK SEAL / SLURRY SEAL	M-F 8:00 AM to 5:00 PM
WHITNEY WY	PACIFICA	CLAY	CRACK SEAL / SLURRY SEAL	M-F 8:00 AM to 5:00 PM
WILLOWBROOK WY	LINDENBR	END	CRACK SEAL / SLURRY SEAL	M-F 8:00 AM to 5:00 PM
WILLOWGROVE LN	FERNGROV	HYDE	CRACK SEAL / SLURRY SEAL	M-F 9:30 AM to 2:00 PM
WINTERGREEN DR	COLD HAR	SOUTH PO	CRACK SEAL / SLURRY SEAL	M-F 8:00 AM to 5:00 PM
ACADIA CT	BEARDON	END	FOG SEAL	M-F 8 AM - 5:00 PM
ALICIA CT	ALCALDE	END	FOG SEAL	M-F 8 AM - 5:00 PM
BLOSSOM LN	FELTON	END	FOG SEAL	M-F 8 AM - 5:00 PM
CORDOVA RD	SANTA LUC	END (BARI	FOG SEAL	M-F 8 AM - 5:00 PM
CRESTON DR	150' N/O R	END	FOG SEAL	M-F 8 AM - 5:00 PM
EL PRADO WY	VOSS	MEDINA	FOG SEAL	M-F 8 AM - 5:00 PM
FELTON WY	KIRWIN	MC CLELLA	FOG SEAL	M-F 8 AM - 5:00 PM
GREENWOOD CT	MILLER	END (SW)	FOG SEAL	M-F 8 AM - 5:00 PM
GREENWOOD DR	MILLER	END (E)	FOG SEAL	M-F 8 AM - 5:00 PM
JOHN WY	KIRWIN	MC CLELLA	FOG SEAL	M-F 8 AM - 5:00 PM
JOLLYMAN LN	STELLING	END	FOG SEAL	M-F 8 AM - 5:00 PM
KRISTA CT	VOSS	END	FOG SEAL	M-F 8 AM - 5:00 PM
LA MAR CT	E ESTATES	END	FOG SEAL	M-F 8 AM - 5:00 PM
LA MAR DR	BLANEY	E ESTATES	FOG SEAL	M-F 8 AM - 5:00 PM
LANSDALE AVE	OAKVILLE	LA MAR	FOG SEAL	M-F 8 AM - 5:00 PM
LEOLA CT	GREENWO	END	FOG SEAL	M-F 8 AM - 5:00 PM
LINDSAY AVE	LA MAR	OAKVILLE	FOG SEAL	M-F 8 AM - 5:00 PM
LONNA LN	KIRWIN	MC CLELLA	FOG SEAL	M-F 8 AM - 5:00 PM
MADERA DR	PHAR LAP	END	FOG SEAL	M-F 8 AM - 5:00 PM
MALVERN CT	LA MAR	END	FOG SEAL	M-F 8 AM - 5:00 PM

STREET NAME	FROM	TO	TREATMENT	LANE CLOSURE HOURS
MANN DR	STEVENS C	140' N/O S	FOG SEAL	M-F 8 AM - 5:00 PM
MANN DR	ADRIANA	PHAR LAP	FOG SEAL	M-F 8 AM - 5:00 PM
MEDINA LN	EL PRADO	LOCKWOO	FOG SEAL	M-F 8 AM - 5:00 PM
MERCEDES RD	CORDOVA	END	FOG SEAL	M-F 8 AM - 5:00 PM
MOLTZEN DR	RUPPELL	CANDLELI	FOG SEAL	M-F 8 AM - 5:00 PM
OAKVILLE AVE	GLENVIEW	LA MAR	FOG SEAL	M-F 8 AM - 5:00 PM
ORLINE CT	JOLLYMAN	END	FOG SEAL	M-F 8 AM - 5:00 PM
PARADISE DR	TERRY	CHERYL	FOG SEAL	M-F 8 AM - 5:00 PM
POPPY DR	FOOTHILL	END	FOG SEAL	M-F 8 AM - 5:00 PM
RODRIGUES AVE	WESTERN	DE ANZA	FOG SEAL	M-F 8 AM - 5:00 PM
RUPPELL PL	KINGSBUR	END	FOG SEAL	M-F 8 AM - 5:00 PM
SALEM AVE	ANTHONY	FOOTHILL	FOG SEAL	M-F 8 AM - 5:00 PM
STANDING OAK CT	VOSS	END	FOG SEAL	M-F 8 AM - 5:00 PM
STONYDALE DR	CRESTON	END	FOG SEAL	M-F 8 AM - 5:00 PM
VOSS AVE	KRISTA CT	END	FOG SEAL	M-F 8 AM - 5:00 PM
DUNBAR DR	GLEN COE	BEARDON	FOG SEAL	M-F 8 AM - 5:00 PM
DUNBAR DR	BEARDON	END	FOG SEAL	M-F 8 AM - 5:00 PM
FARGO DR	BEARDON	END	FOG SEAL	M-F 8 AM - 5:00 PM
FARGO DR	GLEN COE	BEARDON	FOG SEAL	M-F 8 AM - 5:00 PM
GLEN COE DR	ELEND A	HANFORD	FOG SEAL	M-F 8 AM - 5:00 PM
GLEN COE DR	FARGO	GREENLEA	FOG SEAL	M-F 8 AM - 5:00 PM
HANFORD DR	BEARDON	END	FOG SEAL	M-F 8 AM - 5:00 PM
HANFORD DR	GLEN COE	BEARDON	FOG SEAL	M-F 8 AM - 5:00 PM
BLACK OAK WY	SYCAMOR	END	FOG SEAL	M-F 8 AM - 5:00 PM
SYCAMORE DR	OAK VALLE	GATE	FOG SEAL	M-F 8 AM - 5:00 PM
JUNIPER CT	OAK VALLE	END	FOG SEAL	M-F 8 AM - 5:00 PM
ELEND A DR	GLEN COE	End	FOG SEAL	M-F 8 AM - 5:00 PM
E ESTATES DR	JOHN DR	ESTATES D	FOG SEAL	M-F 8 AM - 5:00 PM
DEGAS CT	MEDINA	END	FOG SEAL	M-F 8:00 AM - 5:00 PM
DRAKE CT	DRAKE	END	FOG SEAL	M-F 9:30 AM - 2:00 PM
DRAKE DR	PORTAL	AUBURN	FOG SEAL	M-F 9:30 AM - 2:00 PM
GRAPNEL PL	AMULET	END	FOG SEAL	M-F 9:30 AM - 2:00 PM
PEBBLE PL	AMULET	END	FOG SEAL	M-F 9:30 AM - 2:00 PM
PORTAL AVE	STEVENS C	END (N)	FOG SEAL	M-F 9:30 AM - 2:00 PM



PUBLIC WORKS DEPARTMENT

CITY HALL
10300 TORRE AVENUE ~ CUPERTINO, CA 95014-3266
(408) 777-3354 ~ FAX (408) 777-3333

**ADDENDUM NO. 1
2025 SLURRY SEAL / FOG SEAL
BID OPENING: February 19, 2025
2:00 P.M.**

ISSUED DATE: February 12, 2025

The following questions have been received regarding the above referenced project:

Q1. The NIB mentions retention to be withheld from each progress payment is 50%. Was this meant to be 5%?

A1. Yes. 5% retention will be withheld from each progress payment.

Q2. We understand the apprentice rules but does the skilled workforce apply to this bid where 60% of the workforce need to have graduated from an approved apprenticeship program?

A2. The awarded contractor and their subcontractors must comply with all labor and apprenticeship laws as established by the State of California. This contract is not intended to establish labor compliance or skilled and trained work force requirements beyond those established by the State.

Q3. Will traffic striping, markings, thermos and paint be required to be removed prior to Fog Seal?

A3. No. Striping removal is not required prior to fog seal. See page 100 of Technical Specifications regarding requirements for protection of striping and other facilities prior to fog seal.

All questions regarding this project must be transmitted in writing to Jo Anne Johnson, Public Works Project Manager at joannej@cupertino.gov.

Please indicate receipt of this addendum on the last page of the Proposal. Failure to do so may cause rejection of your bid.

APPROVED BY:

Jimmy Tan
Acting Director of Public Works